

Striving to make products that move you.

ORION

ORION DRY PUMP

Introducing the F Series Lineup.
Newly redesigned for even better reliability.

F series



Compact
Standard Dry Pump
KRF series



Heavy Duty
Standard Dry Pump
KRF series



Combination Dry Pump
CBF series



High-Vacuum Dry Pump
KHF series



5 Concepts Which Define the

Redesigned to Achieve a Higher



1 Environmentally Conscious

Worldwide Forerunner with
RoHS Directive Compliance

ENVIRONMENT FRIENDLY

NEW DESIGN

Established International
Market Share

NEW DESIGN

2 Designed for Safety

- Meets CE Marking Standards (Models with single-phase motors are excluded)
- Special Protective Covering Protects Against Surface Heat and Contact with Moving Parts.

SAFETY DESIGN

The Basis of ORION Dry Pumps

(KRF,CBF series)

Level of Function and Reliability.



Low Noise Design

Reduced Annoying Low Frequency Noise

LOW NOISE

Long Life

Vane Life Increased 30%
(compared to previous models)

LONG LIFE

Annoying low frequency noise (below 500Hz) greatly reduced.

Comparison of noise level by frequency of CBF4040-VB and CBX40 operating at 60Hz, 60kPa vacuum and 60kPa compression

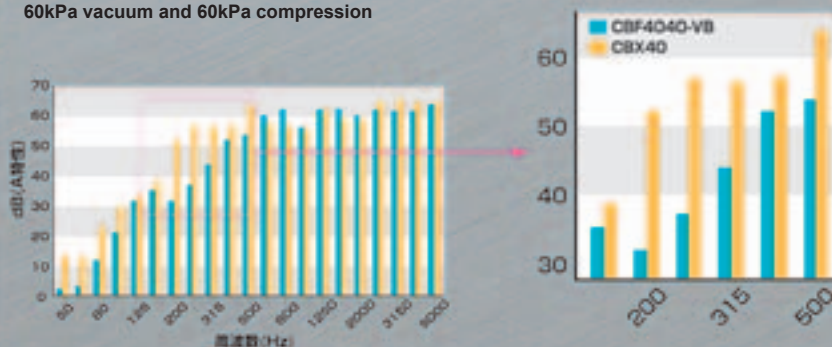

Newly Designed F Series

Normal Capacity Dry Pump KRF series

- Longer Operating Life
Vane Life Increased 30% (KRF 15A, 25A, 40A)
Vane Life Increased 20% (KRF 04A, 08A)
Vane Life Increased 10% (KRF 70, 110)
- Safety Enhanced Design, Environmentally Conscious
CE Marking (Not including single-phase models)
and RoHS Directive Certified
- Low Noise Design



es Dry Pump Lineup

Combination Dry Pump CBF series

- Original Twin Cylinder Design
- Safety Enhanced Design, Environmentally Conscious
CE Marking & RoHS Directives certified
- Improved Ease of Maintenance
- Does Not Require Alignment Adjustments
- Easy To Replace Filter



High Vacuum Dry Pump KHF series

- Safety Enhanced Design
CE Marking Certified (04, 01B models) (Not including single-phase models)
- Easy Vane Replacement (KHF14 · KHF20)
- Operable from ultimate pressure down to atmospheric pressure. (KHF14 · KHF20)

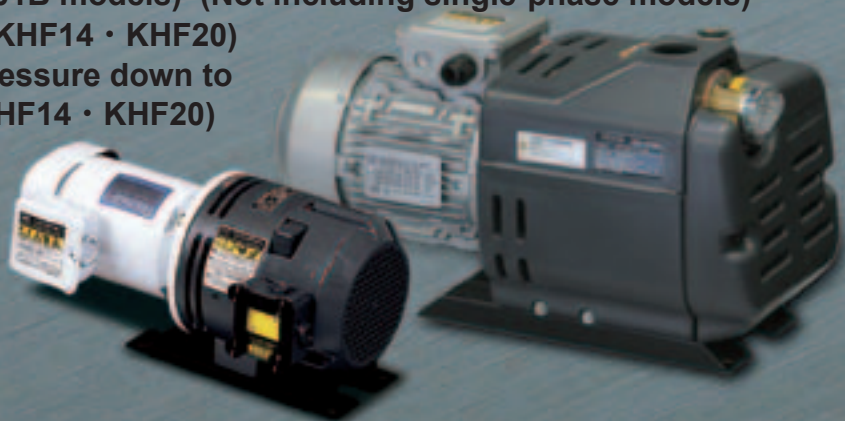

Support for the Ideal Shop Environment

For a Quieter Working Environment

Air Station

10 ~ 15dB Noise Reduction

Pump and Blower System Cabinet (Order Req.)

Multiple pumps and blowers in a single cabinet for easier pump management



Air Cooled AS135A

Exhaust Duct Support

Water Cooled AS135W

Heat output from enclosed pumps cooled via water-cooled condenser. Zero-Level Heat Output!

Silent Box KCS series

5 ~ 10dB Noise Reduction

Matched to Individual Pump



KCS70

KCS110

KCS21A,31A,61A

Index

Product Overview

Model Nomenclature, Functioning Principles, Sample Applications	2 · 3
Pressure Unit Comparison Chart, Pump Pressure Guide, Pressure Units Notes, Conversion Chart, Pump Overview	4 · 5
Choosing the Right Pump	6 ~ 9
Pump and Equipment List	10 · 11

Compact Type



KM41A

KYP series

KRF series

KM41A	12 · 13
KYP Series (Oscillating Piston Pump).....	12 · 13
KRF Series	14 · 15

Standard Type



KRF series

KRF Series	16 ~ 19
------------------	---------

Combination Pumps



CBF series

CBX62

CBXP series

CBF Series	20 · 21
CBX62	22 · 23
CBXP Series	24 ~ 27

High Vacuum Models



KHF series

KHA series

KHH251

KHF Series	28 · 29
KHA Series	30 · 31
KHH251	32

Operating Environment Support



KCS series

AS series

KCS Series (Silent Box)	33 ~ 35
AS135 Series (Pump and Blower System Box)	36

Accessories & Information

Accessories	37 ~ 40
Safety Precautions and Information	41 ~ 44
Energy Savings Proposals	45



Model Nomenclature / Functioning Principles / Sample Applications

ORION DRY PUMPS - ORION IS THE LEADING EXPERT IN OIL-LESS ROTARY VANE PUMP TECHNOLOGY, WITH NEW QUIETER OPERATION AND A LONGER SERVICE LIFE.

Since the development of our first oil-less rotary vane pump in 1965, ORION has constantly upgraded vane pump technology so that the state of the art pumps available today provide an oil free system capable of quiet, durable operation.

The superb performance and multi-purpose function of the ORION Dry Pump have proven to be indispensable in automated industries, saving time and labor in printing and medical applications, precision high-technology production and office machinery, as well as in food processing.

- **ORION Dry Pumps are oil-free for both vacuum and pressure systems, and do not contaminate the work environment and workpieces with oil. These pumps are ideally suited for various applications.**
- **Low operating sound levels and long service life. Pre-equipped with gauges and controllers. (Some models don't apply.)**
- **Specially designed wear-resistant, self-lubricating carbon vanes.**
- **High-speed rotating multi-vane for stable suction / exhaust with little fluctuation.**

Model Nomenclature

Depending on the model, further variations may exist. Please consult the page of the specific model for further details.

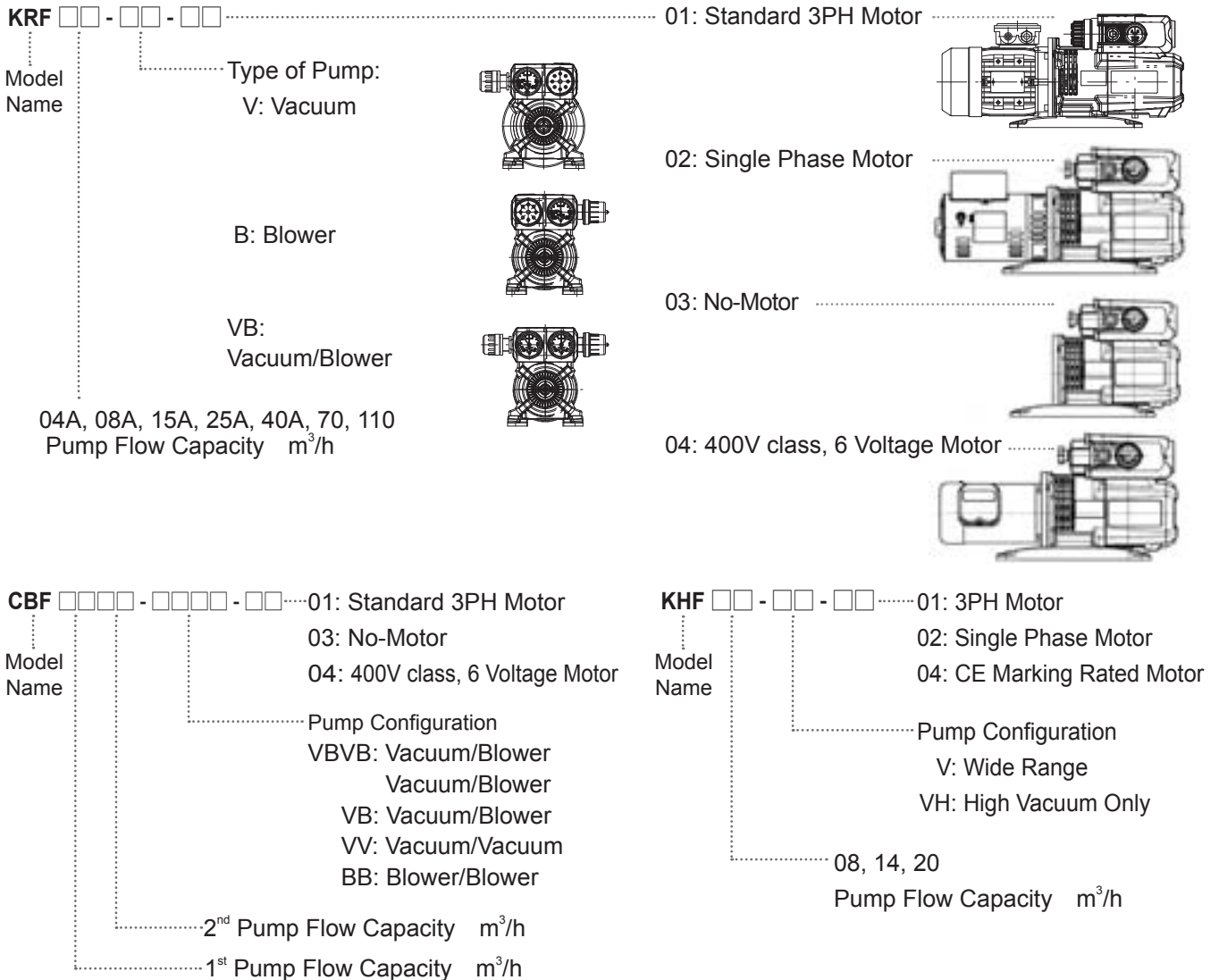

Functioning Principles

- A rotor is placed eccentrically within a cylinder. All components are precisely manufactured and adjusted to achieve minimum clearances. Vanes are inserted into slots in the rotor and are free to slip in and out within the walls of the cylinder. As the rotor turns, the vanes slide out and are kept in constant contact with the cylinder wall due to centrifugal force.
- As the rotor turns, the volume of space between the vanes changes. As shown in the illustration, when the rotor spins from state 1 to 2, the increase in volume at the intake creates a vacuum. As the volume of space between the vanes decreases during the cycle, the air trapped between the vanes is compressed as shown between states 2 and 3. Finally between states 3 and 4 the compressed air is allowed to escape through the air outlet. The process repeats as the rotor continuously rotates in order to achieve a constant air flow from inlet to outlet.
- A four-vane-type pump provides intake/discharge 4 times in a single rotation. Defining volume at the end of intake as $V(L)$, and rotation speed as $N(\text{rpm})$, $4VN(L)$ of air is discharged per minute. This theoretical value is what's known as the designed pumping capacity.

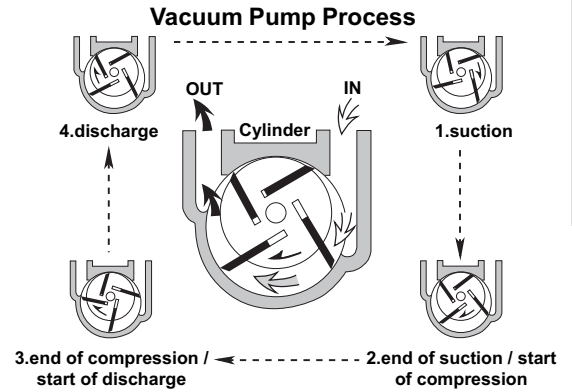

Model Nomenclature

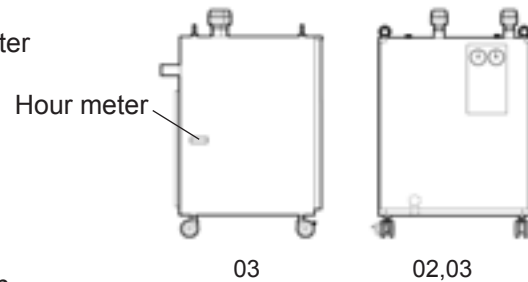
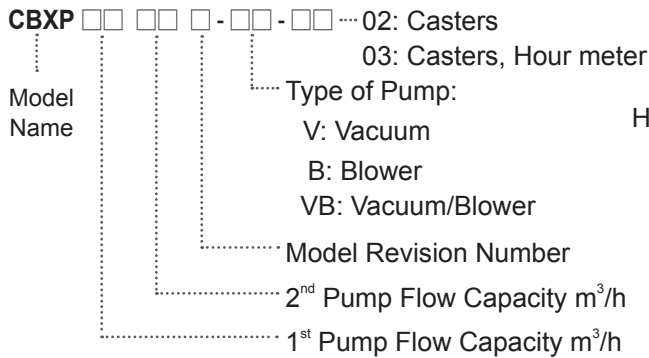

Sample Applications

- Printing Machines ● Binding Machines ● Photographic Processing ● Insertion Machinery ● Vacuum Lift ● Vacuum Chuck ● Robotic Arm ● Packaging Machines ● Vacuum Forming ● Computer Applications ● Paper Counter ● Labeling Machine ● Parts Feeder ● Dust Gas Sampling ● Vacuum Tweezer/Pickup ● Air Bearing ● Oxygen Production ● Medical / Health Care Equipment ● Business Machinery ● Other Automation Machinery Applications

Printing Machine

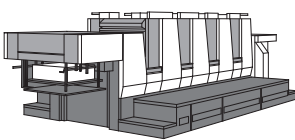

Binding Machine

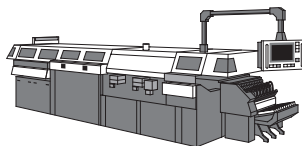
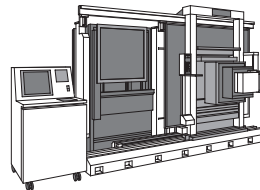
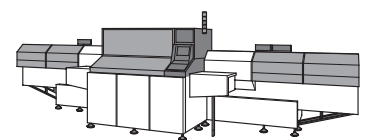

Photo Processing



IC/Component Lift, Placement on PC Board



Automated Machinery

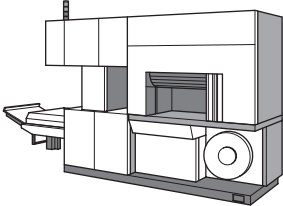

Labeling Machine

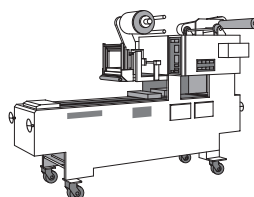

Vacuum Lift

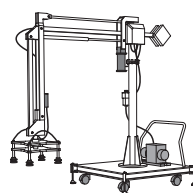

Agitating Equipment

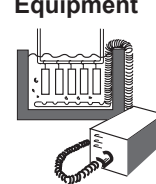

Vacuum Forming

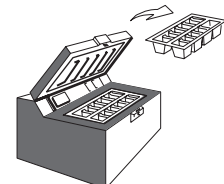



Pressure Unit Comparison / Pump Pressure Guide / Pressure Units Notes / Model List

Pressure Units Comparison Chart

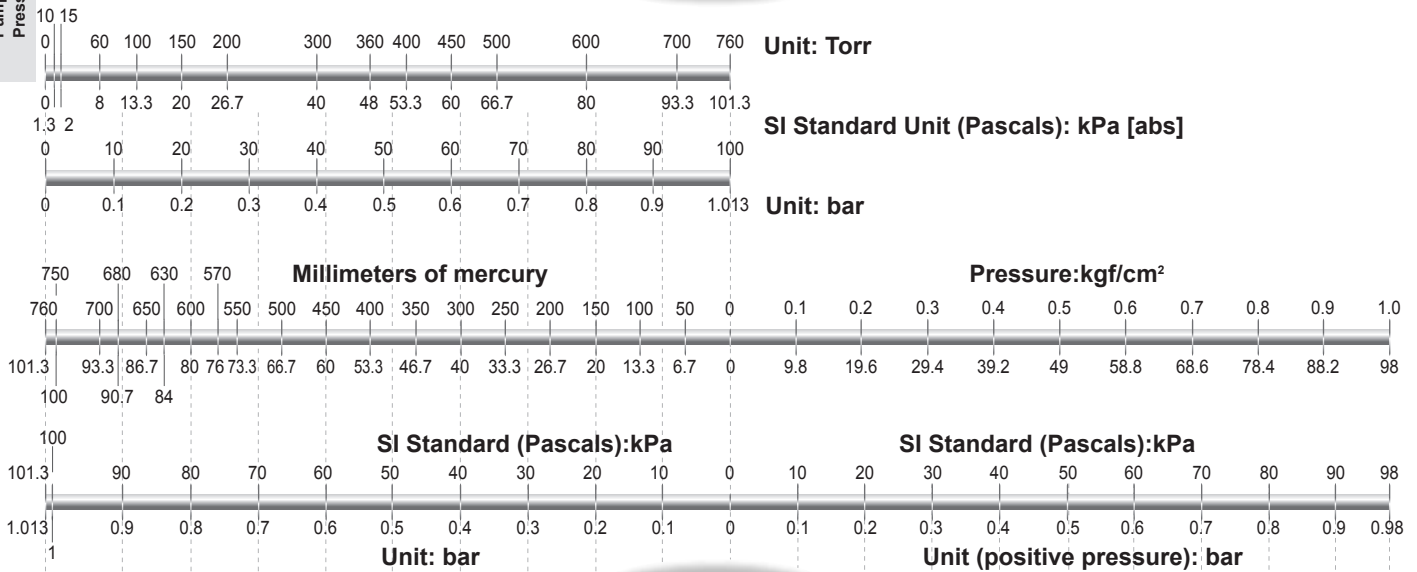

Pump Pressure Guide

Absolute Vacuum Vacuum: kPa Atmospheric Pressure Positive Pressure: kPa

8 [abs]	KHF14-V/20-V	10	Maximum Exhaust Resistance
8 [abs] 48 [abs]	KHF08-VH/KHA100200/400/750	25	Maximum Exhaust Resistance
1.3 abs	KHH251	10	Maximum Exhaust Resistance
10.7 [abs]	KYP40-101	25	Maximum Exhaust Resistance
8 [abs]	KYP90-101	25	Maximum Exhaust Resistance
2.7 [abs]	KYP45H-101	25	Maximum Exhaust Resistance
	55 KM41A		
	55 KRF04A	KRF04A	50
	75 KRF08A/KRF15A	KRF08A/KRF15A	70
80	KRF25A/40A	KRF25A/40A	70
80	KRF70-VH	KRF70-BH	70
80	KRH10		
	60 KRF70-V/110-V	KRF70-B/110-B	60
	60 CBF1515/2525/4040	CBF1515/2525/4040	60
	60 CBX62	CBX62	60
	55 CBX62A :No.1	20 CBX62A :No.1	
	CBX62A :No.2 35	CBX62A :No.2	50
	60 CBXP <input type="checkbox"/> A-VB	CBXP <input type="checkbox"/> A-VB	80
	60 CBXP <input type="checkbox"/> B-VB	CBXP <input type="checkbox"/> B-VB	70
	60 CBXP <input type="checkbox"/> A, <input type="checkbox"/> B-VV	CBXP <input type="checkbox"/> A, <input type="checkbox"/> B-BB	60

Elevation Correction Value

Elevation(m)	Correction Value(kPa)
100	1.2
200	2.4
300	3.6
400	4.7
500	5.9
600	7.0
700	8.1
800	9.3
900	10.4
1,000	11.5

- The elevation correction value is based on the elevation where the pump is operated and this value is to be subtracted from the degree of vacuum.

When operating at atmospheric pressure in areas of high elevation, there will be a difference in the actual degree of vacuum compared to operating at atmospheric pressure at sea level. Accordingly, the upper limit of the continuous degree of vacuum will be lower, and the pump should be operated within the adjusted range. Operating the pump at a degree of vacuum exceeding this adjusted upper limit will shorten the operating lifespan of the pump and can also result in breakdown of the pump. For the same reason, the actual ultimate vacuum will also be lower than the value noted in the specifications.

Example: For operation at an elevation of 500m:

The continuous degree of vacuum of the KRF40A would be in the range of **80-5.9 = 74.1 kPa**.

Pressure Units Notes

Please note that the same units can be used to indicate atmospheric or absolute pressure standard measurements based on the individual case. Please be careful regarding these units.

Degree of Vacuum	Atmospheric Pressure Standard	Absolute Pressure Standard
Notes	<ul style="list-style-type: none"> • Atmospheric Pressure regarded as "0" Also known as "gauge pressure". • We refer to it as "degree of vacuum." A "°" (minus) sign will not be indicated as it is an absolute value. 	<ul style="list-style-type: none"> • Absolute vacuum will be indicated as "0". • Indicated as pressure.
Units	• kPa • mmHg	• kPa [abs] • mbar [abs] • torr

※ mmHg and torr units cannot be used in business transactions.

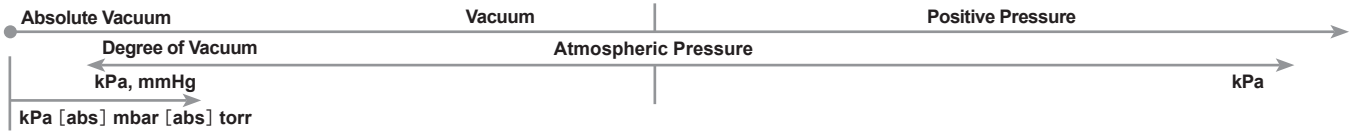

Units Conversion Chart

Vacuum Units		Pressure (Gauge Pressure)		
From	To	kPa	mmHg	mbar
1 kPa	→	1	7.5	10
1 mmHg	→	0.1333	1	1.333
1 mbar	→	0.1	0.75	1

Vacuum Units		Absolute Pressure			
From	To	kPa [abs]	Torr	atm	mbar [abs]
1 kPa [abs]	→	1	7.5	9.87×10^{-3}	10
1 Torr	→	0.1333	1	1.316×10^{-3}	1.333
1 atm	→	1.013×10^2	760	1	1.013×10^3
1 mbar [abs]	→	0.1	0.75	9.87×10^{-4}	1

Pressure Units		Exhaust Pressure (Gauge Pressure)			
From	To	kPa	kgf/cm ²	psi	mbar
1 kPa	→	1	1.02×10^{-2}	1.45×10^{-1}	10
1 kgf/cm ²	→	98.07	1	14.223	9.807×10^2
1 psi(lb/in)	→	6.89	7.031×10^{-2}	1	68.9
1 mbar	→	0.1	1.02×10^{-3}	1.45×10^{-2}	1

Volumetric Units		cfm	m ³ /h	L/min	L/s	m ³ /s
1 cfm(ft ³ /min)	→	1	1.6992	28.32	0.472	4.72×10^{-4}
1 m ³ /h	→	0.589	1	16.67	0.278	2.78×10^{-4}
1 L/min	→	0.0353	0.06	1	0.0167	1.67×10^{-5}
1 L/s	→	2.119	3.6	60	1	10^{-3}
1 m ³ /s	→	2119	3600	60000	1000	1

Model List

Model	Specification	Applications	Model (Three phase- 200V)	Continuous oper- ative vacuum (kPa) Operational (maximum)	Designed pumping capacity L/min (50Hz)	Three-phase motor			Single- phase motor 50/60Hz 100V 200V	Without motor	Other voltage, 3 phase motor 400V class	CE Marking	UL	RoHS Directive	Gauge	Controller	Operational Sound		Page
						50Hz 200V	60Hz 200- 220V	50/60Hz 100V 200V									Without	With	
						Without	With	Without									With		
	V	● Printing / Binding	08A-V-01	60(75)	135	○	○	○	○	MTO	○	MTO	○	○	○	○	60 / 61	50 / 52	P14
	B		08A-B-01	60(70)													64 / 67		
	VB		08A-VB-01	60(75) in total													60 / 61		
	V	● Automation	15A-V-01A	60(75)	235	○	○	○	○	MTO	○	MTO	○	○	○	○	60 / 62	54 / 56	P16
	B		15A-B-01A	60(70)													64 / 65		
	VB		15A-VB-01A	60(75) in total													60 / 62		
	V	● Analytical instrument	25A-V-01B	60(80)	405	○	○	○	○	MTO	○	MTO	○	○	○	○	62 / 64	54 / 56	P16
	B		25A-B-01B	60(70)													65 / 67		
	VB		25A-VB-01B	60(80) in total													62 / 64		
	V	● Packaging requirement 55 ~ 80kPa	40A-V-01B	60(80)	575	○	○	-	○	MTO	○	MTO	○	○	○	○	66 / 67	54 / 56	P16
	B		40A-B-01B	60(70)													68 / 70		
	VB		40A-VB-01B	60(80) in total													66 / 67		
	V	● Aeration, Blower, Discharge pressure requirement 50 ~ 70kPa	70-V-01B	60	1130	○	○	-	○	MTO	○	MTO	○	○	○	○	67 / 68	57 / 58	P18
	B		70-B-01B	60													74 / 76	58 / 60	
	VB		70-VB-01B	60 in total													67 / 68		
	V	● Chip inserter	110-V-01B	60	1850	○	○	-	○	MTO	○	MTO	○	○	○	○	74 / 75	58 / 59	P18
	B		110-B-01B	60													76 / 77	58 / 60	
	VB		110-VB-01B	60 in total													74 / 75		
		● Small parts assembly	100-301 Photo:400	From ultimate pressure to 48(abs)	55	○	○	○	-	MTO	-	MTO	-	Option	Option	60 / 61	47 / 51	P30	
		● Photo engraving	08-VH-01	From ultimate pressure to 48(abs)	125	○	○	MTO	MTO	MTO	○	MTO	-	Option	Option	64 / 67			P28
			08-VH-04 (CE)																
		● Packaging	14-V-01	Overall range	230	○	○	MTO	MTO	MTO	○	MTO	-	Option	Option	66 / 68			P28
			14-V-04 (CE)																
		● Food process	20-V-01A	Overall range	340	○	○	MTO	MTO	MTO	○	MTO	-	Option	Option	67 / 69			P28
			20-V-04 (CE)																

※ Single phase and models without motors.

※ ○ indicates standard equipment.



Selection of Suitable Pump

1. When there is no pressure drop and a vacuum controller is used.

Specific pump choice should take into consideration the variety of conditions in which it will be used. Following are typical configurations based on a simplified set of conditions for the sake of example.

In the case of vacuum lifting, a comparison of grabbing force along with the degree of vacuum, and the size of the area being grabbed.

$$\text{Equation (i)} \quad F = A \times \frac{P}{101.3}$$

Note: The precise formula is $F = A \times P / 98.1 \text{ kPa}$, but for practical use, we assume $101.3 \text{ kPa} \doteq 1 \text{ gkf/cm}^2$.

- F:** Suction force (kg)
- A:** Suction area of vacuum cup (cm²)
- P:** Operational vacuum (kPa)

Graphed, the relationship between these variables is as below:

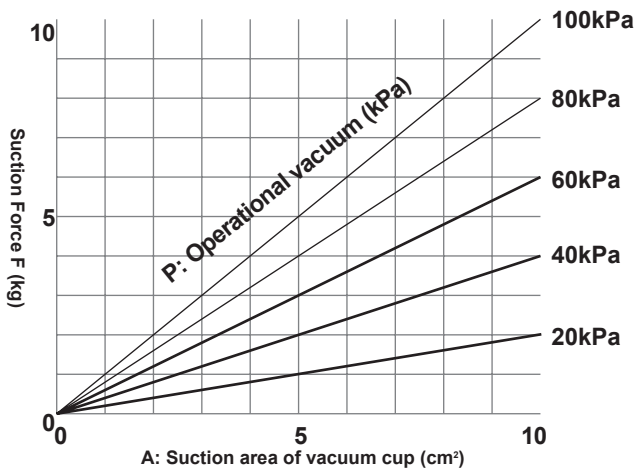

Conversion formulas of pressure related units:

A	B	A=B×7.5	B=A/7.5
mmHg	kPa	A=B×7.5	B=A/7.5
inHg	kPa	A=B/3.387	B=A×3.387
atm	kPa	A=1 - B/101.3	B=101.3×(1 - A)
mbar	kPa	A=B×10	B=A/10
mmAq	kPa	A=B×102	B=A/102
Torr	kPa	A=760 - (B×7.5)	B=(760 - A)/7.5
kPa[abs]	kPa	A=101.33 - B	B=101.33 - A

Lifting and Conveying Objects

When choosing a pump to be used with equipment that repeatedly grabs/moves/releases objects, the pump must be chosen that can attain the required pressure within the required time constraints. Please refer to this example.

Example

- Use: Vacuum lift
- Object conveyed: Aluminum (relative density of 2.7)
- Dimensions: 20cm×30cm×15cm(L×W×H)
- Weight: approx. 25kg
- One processing cycle starts at ① and ends at ⑧.

Task and time

- ① To lower 0.5s ② To grab 0.6s ③ To rise 0.5s
- ④ Move right 0.75s ⑤ To lower 0.25s
- ⑥ To release 0.4s ⑦ To rise 0.25s ⑧ Move left 0.75s
- Piping: 1 1/2B×300cm (from pump to vacuum cup.)
- Vacuum cup volume: 100cm³

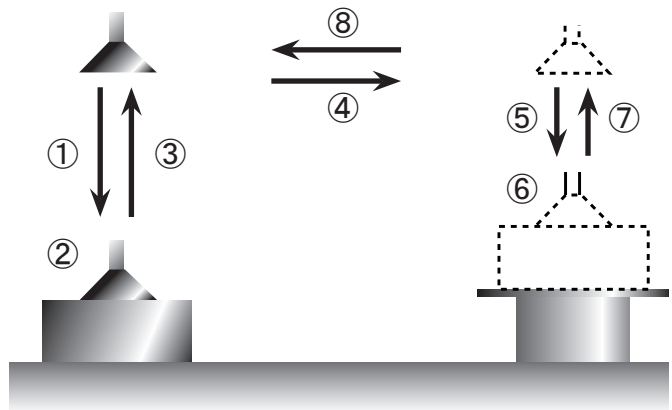

(a) Vacuum cup area calculation

Vacuum cup area depends on the size and shape of the object to be lifted and the operational vacuum. For this example, the operational vacuum is 50kPa.

$$F = 25\text{kg} \quad P = 50\text{kPa}$$

Therefore, equation (i) will be transformed to

$$A = F / \frac{P}{101.3} = 25 / \frac{50}{101.3} = 50.7$$

Consequently, the required vacuum cup area results in 50.7cm²

Taking into consideration surface roughness of the object, piping imperfections, etc., we will apply a Safety Factor of 2. Therefore the area of the vacuum cup should be 101.4cm² (50.7×2.)

※Minimum Safety Factor

When the vacuum cup lifts and holds an object from a horizontal surface, use a Safety Factor of at least 2.

When the vacuum cup lifts and holds an object from a vertical surface, use a Safety Factor of at least 4.

The Safety Factor should be set larger in proportion to leakage loss due to the roughness of the surface to be grabbed, piping imperfections, and other relevant factors.

※ Suction force can be ensured by increasing vacuum when the vacuum cup area is not large enough. Likewise, the vacuum can be lowered when the area of the vacuum cup is larger.

(b) Volume of piping

The volume of piping, V, is the total of the inner volume of pipes and the vacuum cup.

$$V=V1 \text{ (Inner volume of pipes)} + V2 \text{ (Inner volume of vacuum cup:100cm}^3\text{)}$$

(I.D. of 1 1/2B is 4.16cm)

$$V = \pi \times \left(\frac{4.16}{2} \right)^2 \times 300 + 100 = 4175\text{cm}^3 \text{ (4.2L)}$$

Size, inside diameter, and cross section area of pipes are as below:

Pipe		Inside Diameter cm	Cross Section cm ²	Pipe		Inside Diameter cm	Cross Section cm ²
A	B			A	B		
6	1/8	0.65	0.332	40	1 1/2	4.16	13.585
8	1/4	0.92	0.664	50	2	5.29	21.968
10	3/8	1.27	1.266	65	2 1/2	6.79	36.192
15	1/2	1.61	2.035	80	3	8.07	51.123
20	3/4	2.16	3.662	90	3 1/2	9.32	68.187
25	1	2.76	5.980	100	4	10.53	87.042
32	1 1/4	3.57	10.005	125	5	13.08	134.303

From the above, time required to grab object (0.60s), operational vacuum (50kPa), and piping inner volume (4.2L) are determined. A suitable pump model can be chosen based on the operational vacuum, the grabbing time (the time till operational vacuum is attained), and the piping inner volume. In this case, the operational vacuum is 50kPa, therefore, graph 2 on page 8 must be referenced. First, seek the intersection of the required time till the operational vacuum is attained (grab time) and the piping inner volume. Then a model whose line appears above that point would be selected. In this example, **KRF40A** would be a suitable choice.



Selection of Suitable Pump

(c) Selection may also be done from calculations and pump performance charts. Below is an example using the same case as (b)

$$\text{Equation (ii)} \quad S = \frac{138.2 \times V}{\Delta t} \times \log \frac{P_0 - P_1}{P_0 - P_2}$$

S: Flow demand (L/min)		P0: Ultimate vacuum of pump	90kPa
V: Piping inner volume	4.2L	P1: Initial pressure inside pipes	0kPa
Δ t: Time to grab	0.6s	P2: Vacuum (Suction force)	50kPa

341 L/min is figured from the above.

From the above equation we conclude that the required flow demand is **341 L/min**.

On the vacuum performance graph (Graph 5) we select the point at the intersection of the flow rating of **341** and on the horizontal axis, the midpoint between P1 and P2, which is 25. The nearest line above this point indicates **KRF40A** is a suitable model.

Graphs for Pump Selection

Graph 1 (at 40kPa)

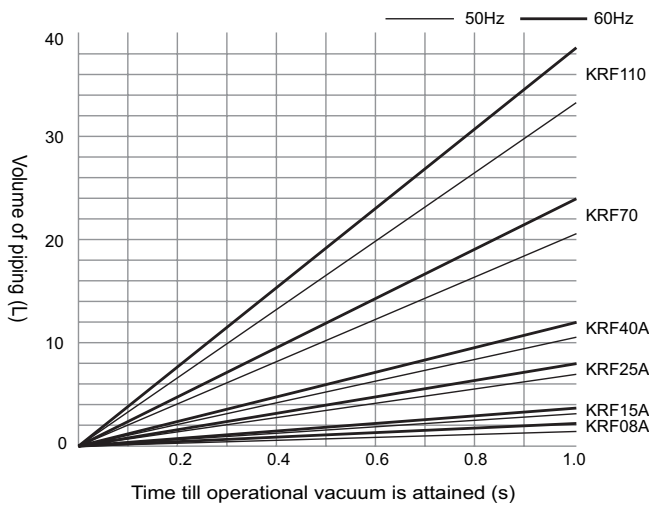

Graph 2 (at 50kPa)

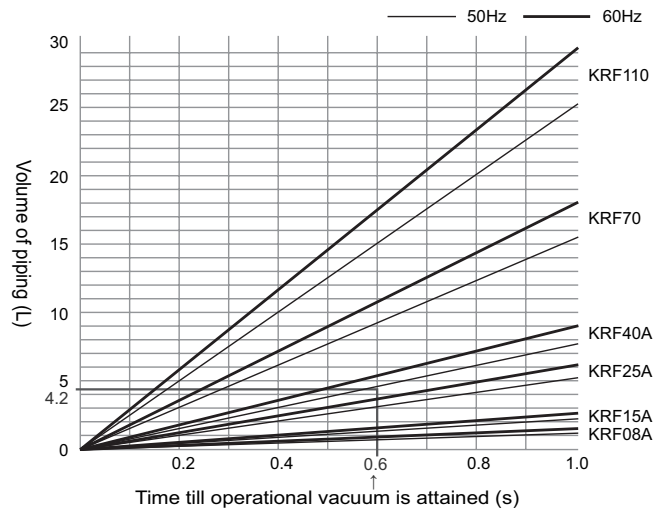

Graph 3 (at 55kPa)

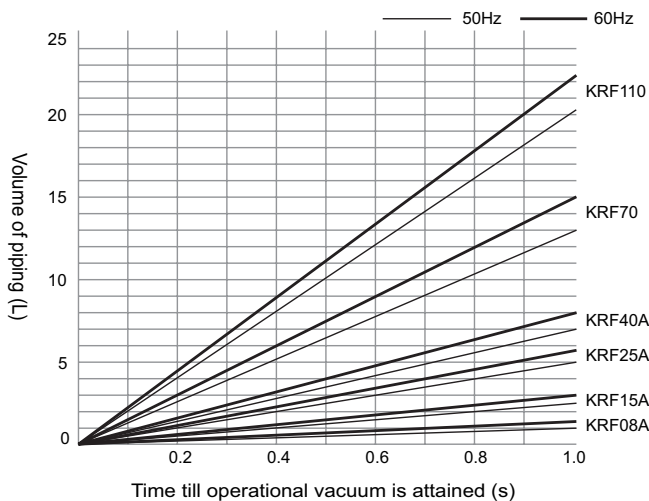

Graph 4 (at 60kPa)

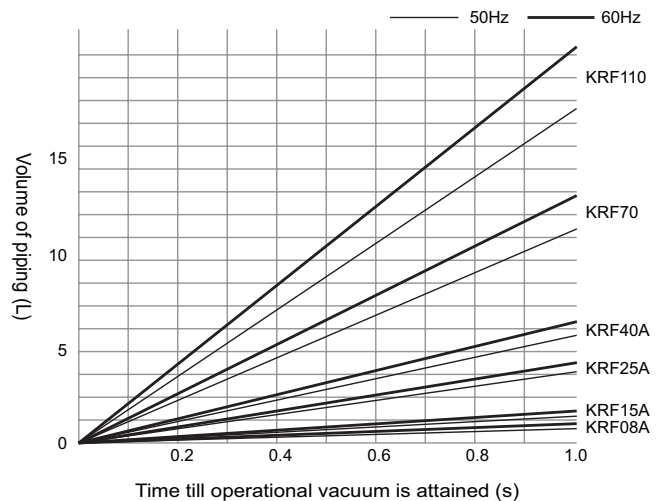

Regarding Pressure Loss

■ **Total pressure loss of piping (ΣP_i)**

$$\Sigma P_i = p_1 + p_2 + p_3 + p_4 + \dots + p_n \quad p_i: \text{pressure loss of each pipe}$$

■ **Pressure loss of each section (each piping size) $P_i = 7.15 \times L \times Q^2 \div D^5$**

p_i : Pressure loss of each pipe. (kPa)

L : Piping Length (m)

The pressure loss is in proportion to the length of the piping.

Calculate the piping length from the piping layout.

Q : Flow rate through the piping (L/min)

the pressure loss will be in proportion to the square of the flow rate. The flow rate is regarded as the air capacity of the selected vacuum pump at 0kPa.

D : Inner diameter of the piping (diameter) (mm)

The pressure loss is inversely proportional to the inner diameter of the piping raised to the fifth power. when the inner diameter becomes larger, pressure loss is greatly reduced.

2. When there is pressure drop and a vacuum controller is not used.

Influences from various conditions must be considered in choosing an appropriate pump. Plain and simple methods are described here with examples of typical applications.

S : Flow demand (L/min)

V : Piping inner volume (L)

Δt : Time to grab 0.6s

P_0 : Ultimate vacuum of pump (kPa)

P_1 : Initial pressure inside pipes (kPa)

P_2 : Vacuum (suction force) (kPa)

$$S = \frac{138.2 \times V}{\Delta t} \times \log \frac{P_0 - P_1}{P_0 - P_2}$$

(ii) Even though the calculation is the same as in equation (ii), S -flow demand is not defined in the same way. Please refer to the table below.

Vacuum controller used		
S	No pressure loss	With pressure loss
	At intermediate point between P_1 and P_2	At intermediate point between pressure drop and P_2
Vacuum controller not used		
S	No pressure loss	With pressure loss
	At P_1	At pressure drop

Graph 5 (Performance curve)

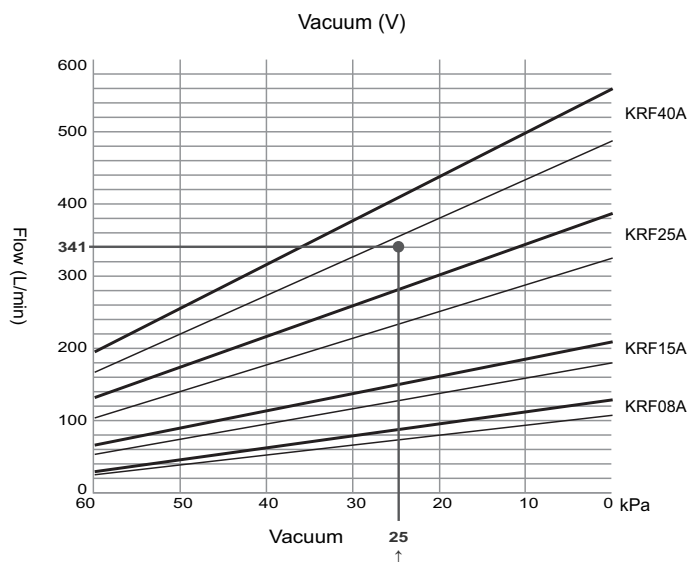



Model List

Standard Optional

Note: Please refer to product page in this catalogue for further product specifications and information.

Model	Pump No.	Vacuum use (V)	Blower use (B)	Vacuum & Blower (VB)	Drive		Compound gauge type A / type D	Main equipment										
					Separated	Direct-coupled		Vacuum controller	Pressure controller	Filter case	Oil separator	Water separator	Clean filter	After cooler	Vacuum switch			
																type A	type D	
Compact KM	KM41A-101							VC10										
Oscillating Piston KYP	40-101-G1																	
	90-101-G1																	
	45H-101-G1																	
Compact Standard Model KRF	04A-V-01/02A							VC32		RA-05A-V,05A-M	RA31	RA41	RA53S					
	04A-B-01/02A								PC32	RA-05A-S,05A-B			RA53D					
	04A-VB-01/02A							VC32	PC32	RA-05A-V,05A-B	RA31	RA41	RA53S,D					
	08A-V-01/02A							VC32		SDF25(V)	RA31	RA41	RA53S					
	08A-B-01/02A								PC32	SDF15(B)			RA53D					
Standard Model KRF	08A-VB-01/02A							VC32	PC32	SDF25(VB)	RA31	RA41	RA53S,D					
	15A-V-01A/02/04							VC63		SDF25(V)	RA31	RA41	RA53S					
	15A-B-01A/02/04								PCA6	SDF15(B)			RA53D					
	15A-VB-01A/02/04							VC63	PCA6	SDF15(VB)	RA31	RA41	RA54D					
	25A-V-01B/02/04B							VC63		SDF25(V)	RA31	RA41	RA54S					
	25A-B-01B/02/04B								PCA6	SDF25(B)			RA54D					
	25A-VB-01B/02/04B							VC63	PCA6	SDF15(VB)	RA31	RA41	RA54S,D					
	40A-V-01B/04B							VC63B		SDF40(V)	RA31	RA41	RA55S					
Heavy Duty Standard Model KRF	40A-B-01B/04B								PCA6	SDF40(B)			RA55D					
	40A-VB-01B/04B							VC63B	PCA6	SDF40(VB)	RA31	RA41						
	70-V-01B/04B							VC81		VFF70 MFF70	RA32	RA42	RA56S					
	70-B-01B/04B								PCA8	SFF70 PSF70			RA56D					
	70-VB-01B/04B							VC81	PCA8	VFF70 PSF70	RA32	RA42	RA56S,D					
	70-VH-01B/04B							VC81		VFF70 MFF70H	RA32	RA42	RA56S					
	70-BH-01B/04B								PCA8	SFF70 PSF70H			RA56D					
	70-VBH-01B/04B							VC81	PCA8	VFF70 PSF70H	RA32	RA42	RA56S,D					
Combination Pump CBF	110-V-01B/04B							VC100B		VFF110 MFF110			RA57S					
	110-B-01B/04B								PCA10	SFF110 PSF110			RA57D					
	110-VB-01B/04B							VC100B	PCA10	VFF110 PSF110			RA57S,D					
	1515-VB-01B/04B	1							VC63		SDF25(V)	RA31	RA41	RA53S				
		2								PCA6	SDF15(B)			RA53D				
	1515-VBVB-01B/04B	1							VC63	PCA6	SDF25(VB)	RA31	RA41	RA53S,D				
		2							VC63	PCA6	SDF25(VB)	RA31	RA41	RA53S,D				
	1515-VV-01B	1,2						VC63		SDF25(V)	RA31	RA41	RA53S					
1515-BB-01B	1,2							PCA6	SDF15(B)			RA53D						
2525-VB-01B/04B	1							VC63		SDF25(V)	RA31	RA41	RA54S					
	2								PCA6	SDF25(B)			RA54D					
2525-VBVB-01B/04B	1							VC63	PCA6	SDF25(VB)	RA31	RA41	RA54S,D					
	2							VC63	PCA6	SDF25(VB)	RA31	RA41	RA54S,D					
2525-VV-01B	1,2						VC63		SDF25(V)	RA31	RA41	RA54S						
2525-BB-01B	1,2							PCA6	SDF25(B)			RA54D						
4040-VB-01B/04B	1							VC63B		SDF40(V)	RA31	RA41	RA55S					
	2								PCA6	SDF40(B)			RA55D					
4040-VBVB-01B/04B	1							VC63B	PCA6	SDF40(VB)	RA31	RA41	RA55S,D					
	2							VC63B	PCA6	SDF40(VB)	RA31	RA41	RA55S,D					
4040-VV-01B	1,2						VC63B		SDF40(V)	RA31	RA41	RA55S						
4040-BB-01B	1,2							PCA6	SDF40(B)			RA55D						

Model		Pump No.	Vacuum use (V)	Blower use (B)	Vacuum & Blower (VB)	Drive		Compound gauge type A / type D	Type A	Main equipment								
						Separated	Direct-coupled			Vacuum controller	Pressure controller	Filter case	Oil separator	Water separator	Clean filter	After cooler	Vacuum switch	
																		Type D
Combination Pump CBX	62-01B-G1	1								VC81		VFS8A MFS8A	RA32	RA42	RA56S			
		2									PCA8	SFS8A PSS8A			RA56D	DA61		
	62-A-01B-G1	1									VC81	PCA8	VFS8A PSS8A	RA32	RA42	RA56S · D	DA61	
		2									VC81	PCA8	SFS8A PSS8A	RA32	RA42	RA56S · D	DA61	
Combination Pump One-Package CBXP	6070A-VB-02B	1								VC81		VFS8A MFS8A	RA32	RA42	RA56S			
		2									PCA8	SFS8A PSS8A			RA56D			
	8080B-VB-02B/03B	1									VC81		VFS8A MFF70	RA32	RA42	RA56S		
		2										PCA10	SFS8A PSF70			RA57D		
	90110B-VB-02B/03B	1									VC100A		VFS8A MFF70	RA32		RA57S		
		2										PCA10	SFF110 PSF110					
	6060A-VV-02B	1,2								VC81		VFS8A MFS8A	RA32	RA42	RA56S			
	8080B-VV-02B/03B	1,2								VC81		VFS8A MFF70	RA32	RA42	RA56S			
	9090B-VV-02B/03B	1,2								VC100A		VFS8A MFF70	RA32		RA57S			
	110110B-VV-02B/03B	1,2								VC100B		VFF110 MFF110						
	6060A-BB-02B	1,2									PCA8	SFS8A PSF8A			RA56D			
	8080B-BB-02B/03B	1,2									PCA8	SFS8A PSF70			RA56D			
	9090B-BB-02B/03B	1,2									PCA10	SFS8A PSF70			RA57D			
110110B-BB-02B/03B	1,2									PCA10	SFF110 PSF110							
Direct Coupled Motor High Vacuum KHF	08-VH-01									VC32※2			RA31		RA53S			
	14-V-01									VC63※3			RA31		RA53S			
	20-V-01B									VC63※3			RA31		RA54S			
High Vacuum KHA	100-301-G1									VC32※1			RA31		RA53S			
	200-301A-G1									VC32※2			RA31		RA53S			
	400-301A-G1									VC63※2		RA-05A-V	RA31		RA53S			
	750-301B-G1									VC63※2		RA-05A-V	RA31		RA54S			
High Vacuum KHH	251-101											RA31						

※1 Adjustable range of vacuum : 28 ~ 48kPa [abs]. ※2 Adjustable range of vacuum : 21 ~ 48 kPa [abs]. ※3 Adjustable range of vacuum : 21kPa [abs] and over. ※Please note that there may be different part numbers for parts with the same part name.



Compact KM Model Compact Oscillating Piston KYP Series

Continuous operating vacuum:
55kPa or lower
Flow rate:
29L/min (60Hz)

Ultimate pressure: 10.7 ~ 2.7kPa [abs]
Flow rate: 33 ~ 85L/min (60Hz)



KM41A-101-G1



KYP90-101-G1

KYP40-101-G1

KYP45H-101-G1

KM Features

- Free rotor drive -- no side adjustment necessary.
- Easy Maintenance
- Oil free pumps operate without oil so your working environment and equipment stay free from oil contamination.
- Can be hooked up directly to rubber or vinyl hoses.

KYP Features

- Oil Free: Built with a specialized resin cap seal.
- Low Noise / Light Weight: 53dB (reference only), Aluminium Casing Integrated Models
- Easy Maintenance

KM Specifications

□ single phase ■ 3 phase

Model	Designed pumping capacity				Ultimate vacuum	Continuously operational vacuum	Suction/ exhaust port diameter	Voltage				Standard motor current rating				Noise level		Motor	Mass			
	L/min ※1		Over:kPa ※2					Under:kPa ※3	Single phase	3 phase		A		dB※4	kW	Single phase	3 phase					
	50Hz	60Hz	50Hz	60Hz						100V	100/200V	200V	220V						100V	200V	200V	220V
	50/60Hz		50/60Hz							50/60Hz		60Hz							50/60Hz		60Hz	
KM41A-101-G1	24	29	67	75	55	Hose nipple Outside diameter : φ10	○	—	—	—	1.1/ 1.2	—	—	—	60	61	0.06	4.6	—			

※1 Designed pumping capacity: Theoretical value calculated from cylinder volume. Refer to "Performance Data" for actual flow rate. ※2 Operation not allowed at ultimate vacuum. For model selection purposes only. ※3 Operable range of vacuum (pressure). ※4 Operating noise measured on a new pump with an ORION recommended motor running at normal vacuum/pressure conditions. Operating noise levels are from a position of 1m in front of the unit and at a height of 1m. ※ A compound gauge and vacuum controller are not included as standard equipment. Install a compound gauge and vacuum controller VC10 on the vacuum piping before the filter and use at a normal degree of vacuum. ※ Operating environment (inlet air) conditions: air temp: 0 ~ 40°C, humidity: normal levels (65±20%). ※ Allowable intermittent power supply voltage fluctuation range is ±10% of the specified voltage; allowable sustained supply voltage fluctuation range is ±5% of the specified voltage. ※Please install an overload protection device (such as a thermal relay). Setting guideline: Use the current rating listed on the motor nameplate as a guide. For detailed specifications, please refer to the specifications sheet.

KYP Specifications

□ Single phase ■ 3 Phase model

Model	Designed pumping capacity		Ultimate pressure (min.)	Air inlet/ outlet port diameter	Voltage	Standard motor current rating	Noise level		Motor	Mass				
	L/min ※1						kPa [abs] ※2	Single phase			Single phase	dB※3		
	50Hz	60Hz											100V	100V
	50/60Hz												50/60Hz	
KYP--														
40-101-G1	28	33	10.7	Rc1/4	○	3.0/1.9	48	52	0.15	7.5				
90-101-G1	75	85	8.0	Rc1/4	○	3.2/3.1	52	52	0.25	10				
45H-101-G1	40	47	2.7	Rc1/4	○	3.0/2.7	51	53	0.25	10				

※1 Designed pumping capacity: Theoretical value calculated from cylinder volume. Refer to "Performance Data" for actual flow rate. ※2 Pump can be continuously operated at the maximum attainable vacuum. ※3 Operating noise level measured on a new pump with the standard built-in ORION motor. Operating noise levels are from a position of 1m in front of the unit and at a height of 1m. ※ Operating environment (inlet air) conditions: air temp: 7 ~ 40°C, humidity: normal levels (65±20%). ※ Allowable intermittent power supply voltage fluctuation range is ±10% of the specified voltage; allowable sustained supply voltage fluctuation range is ±5% of the specified voltage. ※ Please install an overload protection device (such as a thermal relay). Setting guideline (may vary depending on the specific application): KYP40: 4.3A@50Hz, 2.1A@60Hz. KYP90/KYP45H: 3.8A@50Hz, 3.4A@60Hz. ※ For detailed specifications, please refer to the specifications sheet.

Performance Data

(— 50Hz — 60Hz)

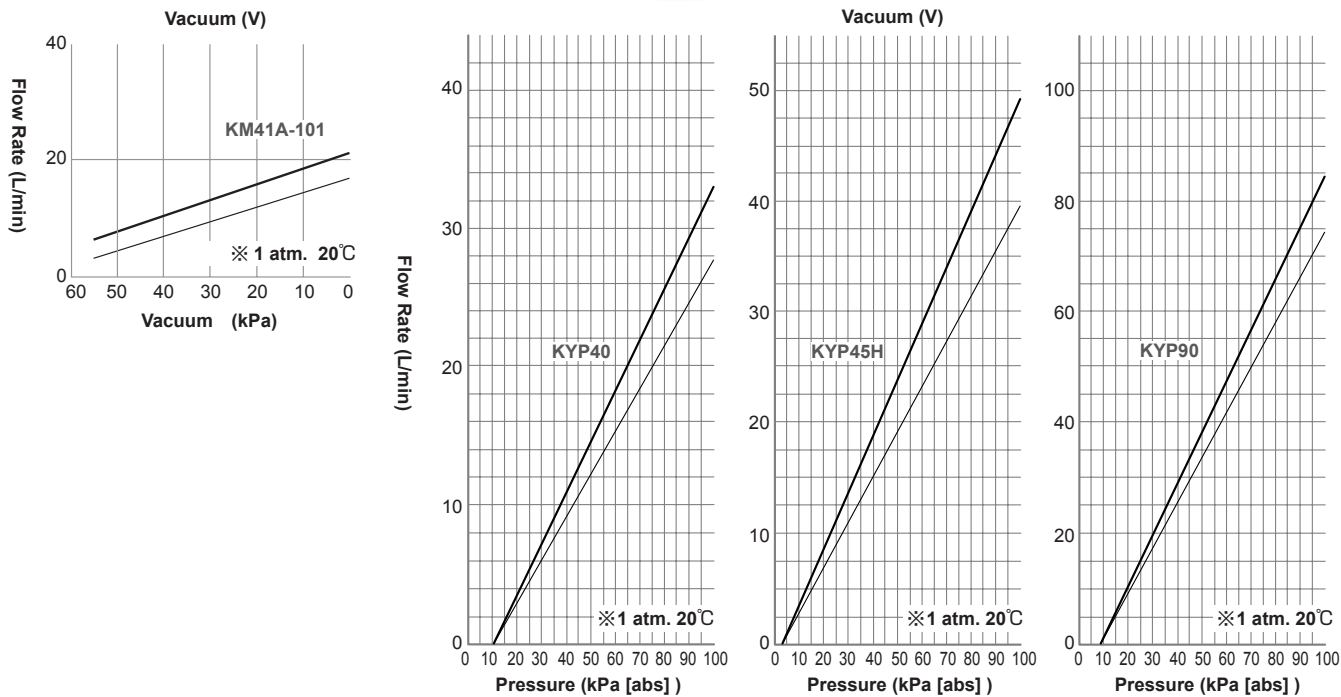

Compact KM Series

Outside Dimensions (Units:mm)

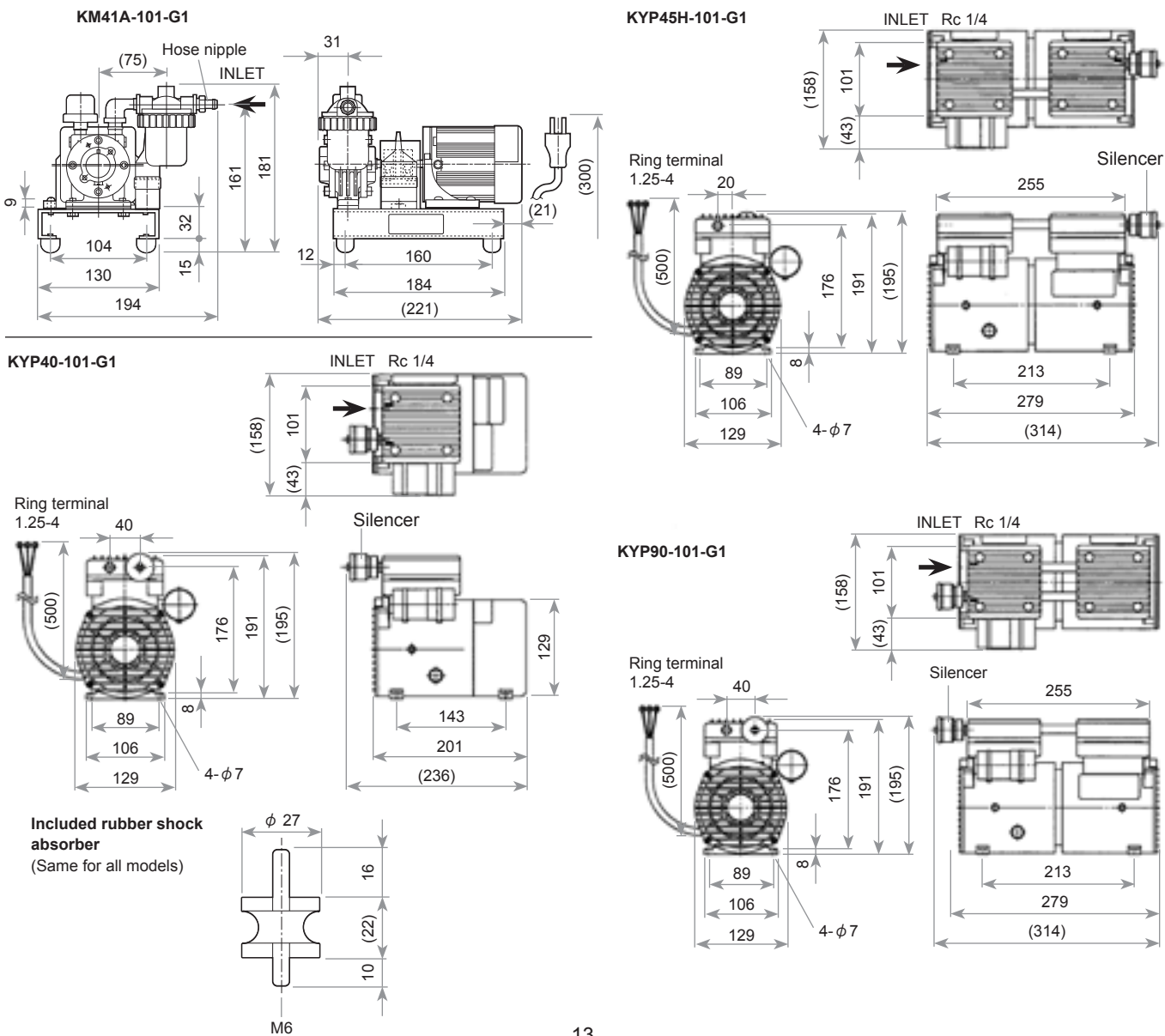



Compact Standard Pump KRF Series

Safety Enhanced Design • Low Noise • Long Life • Environmentally Friendly

Continuous Operative Vacuum

KRF04A: max. 55kPa
KRF08A: Recomm. 60kPa or below (max. 75kPa)

Continuous Operative Pressure

KRF04A: max. 50kPa
KRF08A: Recomm. 60kPa or below (max. 70kPa)

Flow rate: 75 ~ 155L/min (60Hz)

CE Marking Certified ※1
RoHS Directive Compliant



KRF04A-V-01



KRF08A-V-01

Features

- Proven Design, Environmentally Friendly ... CE Marking Certified ※1
- Low Noise Reduced Noise Design quieter by 2 ~ 5dB (compared with our earlier models.)
- Long Life ... New blade material yields an increase of 20% (compared with our earlier models.)

Applications

- Vacuum Source for automation equipment, analysis equipment, packaging equipment, printing equipment, book making equipment, etc.

Specifications

Single phase motor 3 phase motor

Model	Designed pumping capacity		Ultimate vacuum		Continuous operational vacuum		Continuous operational pressure		Suction/exhaust port dia.	Voltage						Standard motor current rating A				Noise level		Motor	Mass	
										Single phase (02A)			3 phase (01)			Single phase (02A)		3 phase (01)						
										100/200V	200V	220V	100V	200V	200V	220V	50/60Hz	60Hz	50/60Hz					
	L/min ※2		kPa(min.) ※3		kPa (max.) ※4		kPa (max.) ※4		3 phase(04)※5						3 phase(04)※5							kg		
	50Hz 60Hz		50Hz 60Hz		Recom. Max.		Recom. Max.		380V 400V 415V 400V 440V 460V	380V 400V 415V 400V 440V 460V	380V 400V 415V 400V 440V 460V	380V 400V 415V 400V 440V 460V	50Hz 50Hz 50Hz 60Hz 60Hz 60Hz	50Hz 50Hz 50Hz 60Hz 60Hz 60Hz	50Hz 50Hz 50Hz 60Hz 60Hz 60Hz	50Hz 50Hz 50Hz 60Hz 60Hz 60Hz	50Hz 60Hz	dB※6	kW	Single phase	3 phase			

KRF04A- □ - □

V-01	63	75	70	75	55	—	—	Rc 3/8	—	○	○	—	0.69/0.6	0.62	61	63	0.1	—	10.5		
V-02A	63	75	70	75	55	—	—	Rc 3/8	○	—	—	1.9/1.7	1.0/0.9	—	61	63	0.1	12	—		
V-04	63	75	70	75	55	—	—	Rc 3/8	○	○	○	0.34	0.35	0.30	0.31	0.32	61	63	0.1	—	10.5
B-01	63	75	—	—	—	50	—	Rc 3/8	—	○	○	—	0.69/0.6	0.62	61	64	0.1	—	10.5		
B-02A	63	75	—	—	—	50	—	Rc 3/8	○	—	—	1.9/1.7	1.0/0.9	—	61	64	0.1	12	—		
B-04	63	75	—	—	—	50	—	Rc 3/8	○	○	○	0.34	0.35	0.30	0.31	0.32	61	64	0.1	—	10.5
VB-01	63	75	—	—	55 or less altogether		—	Rc 3/8	—	○	○	—	0.69/0.6	0.62	61	63	0.1	—	10.5		
VB-02A	63	75	—	—	55 or less altogether		—	Rc 3/8	○	—	—	1.9/1.7	1.0/0.9	—	61	63	0.1	12	—		
VB-04	63	75	—	—	55 or less altogether		—	Rc 3/8	○	○	○	0.34	0.35	0.30	0.31	0.32	61	63	0.1	—	10.5

KRF08A- □ - □

V-01	135	155	78	78	60	75	—	—	Rc 3/4	—	○	○	—	1.3/1.1	1.1	60	61	0.2	—	14			
V-02A	135	155	78	78	60	75	—	—	Rc 3/4	○	—	—	3.3/2.9	1.7/1.5	—	60	61	0.2	15.5	—			
V-04	135	155	79	79	60	75	—	—	Rc 3/4	○	○	○	0.62	0.64	0.65	0.55	0.57	0.58	60	61	0.2	—	14
B-01	135	155	—	—	—	60	70	—	Rc 3/4	—	○	○	—	1.3/1.1	1.1	64	67	0.2	—	14			
B-02A	135	155	—	—	—	60	70	—	Rc 3/4	○	—	—	3.3/2.9	1.7/1.5	—	64	67	0.2	15.5	—			
B-04	135	155	—	—	—	60	70	—	Rc 3/4	○	○	○	0.62	0.64	0.65	0.55	0.57	0.58	64	67	0.2	—	14
VB-01	135	155	—	—	75 or less altogether		—	Rc 3/4	—	○	○	—	1.3/1.1	1.1	60	61	0.2	—	14				
VB-02A	135	155	—	—	75 or less altogether		—	Rc 3/4	○	—	—	3.3/2.9	1.7/1.5	—	60	61	0.2	15.5	—				
VB-04	135	155	—	—	Total: sugg. 60, max.75		—	Rc 3/4	○	○	○	0.62	0.64	0.65	0.55	0.57	0.58	60	61	0.2	—	14	

※1 Models with single phase motors and models without motors are excluded. ※2 Designed pumping capacity: Theoretical value calculated from cylinder volume. Refer to "Performance Data" for actual flow rate. ※3 Operation not allowed at ultimate vacuum. For model selection purposes only. ※4 Operable range of vacuum (pressure). ※5 "04" models are special order items. ※6 Operating noise values are based on a new unit equipped with the standard Orion motor, and running at the standard operating vacuum / pressure. Operating noise levels are from a position of 1m in front of the unit and at a height of 1m. ※ Operating environment (intake air) conditions: Temperature: 0~40°C, humidity: normal (65±20%). ※ Allowable intermittent power supply voltage fluctuation range is ±10% of the specified voltage; allowable sustained supply voltage fluctuation range is ±5% of the specified voltage. ※ Please install an overload protection device (such as a thermal relay). Setting guideline (may vary depending on the specific application): KRF04A- □ -01 models: 200V/50Hz @ 0.8A, 200V/60Hz and 220V/60Hz @ 0.7A. KRF04A-V-02A/B-02A models: 100V/50Hz @ 2.1A, 100V/60Hz @ 1.7A, 200V/50Hz @ 1.1A, 200V/60Hz @ 0.9A. KRF04A-VB-02A models: 100V/50Hz @ 2.2A, 100V/60Hz @ 1.7A, 200V/50Hz @ 1.2A, 200V/60Hz @ 0.9A. KRF08A- □ -01 models: 200V/50Hz @ 1.7A, 200V/60Hz and 220V/60Hz @ 1.4A. KRF08A-V-02A models: 100V/50Hz @ 3.3A, 100V/60Hz @ 2.9A, 200V/50Hz @ 1.7A, 200V/60Hz @ 1.5A. KRF08A-B-02A/VB-02A models: 100V/50Hz @ 3.3A, 100V/60Hz @ 3.2A, 200V/50Hz @ 1.7A, 200V/60Hz @ 1.7A.

※ For detailed specifications, please refer to the specifications sheet.

Performance Data

(— 50Hz — 60Hz)

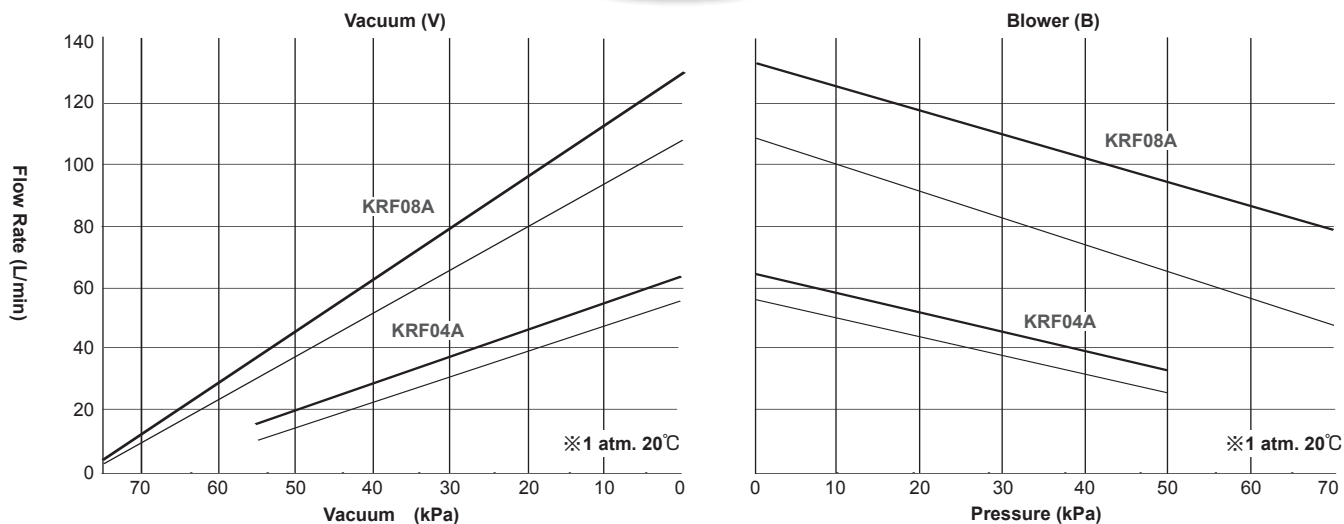

Compact Standard Pump
KRF Series

Outside Dimensions (Units:mm)

KRF04A-V-01,04

※ Figures in { } indicate KRF04A-V-02A dimensions.

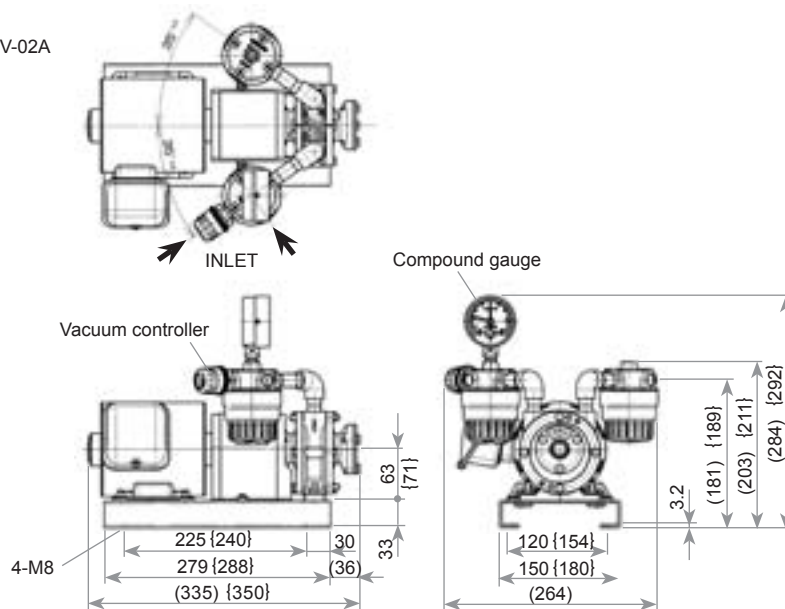

KRF08A-V-01,04

※ Figures in { } indicate KRF08A-V-02A dimensions.

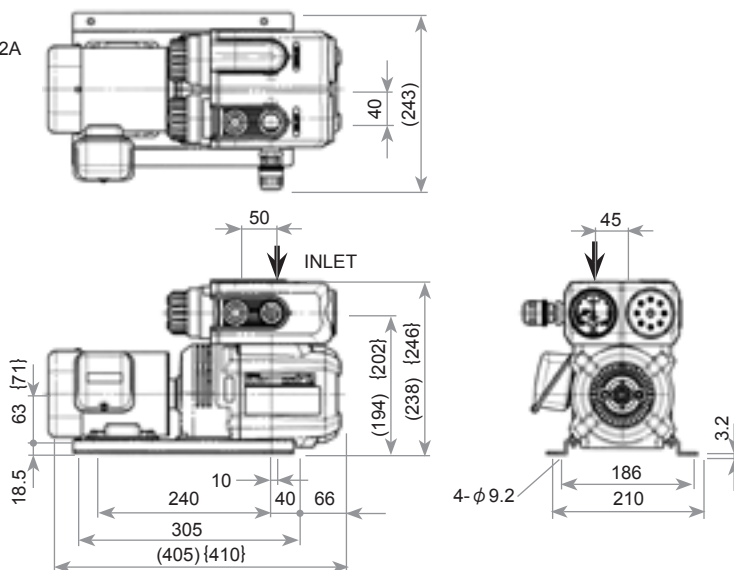



Standard Pump KRF Series



Safety Enhanced Design • Low Noise • Long Life • Environmentally Friendly

Continuously Operational Vacuum
 Recomm. 60kPa or less (max. 80kPa)
 Max 75kPa for KRF15A

Continuously Operational Pressure
 Recomm. 60kPa or less (max. 70kPa)

Capacity
 280685 L/min (60Hz)

CE Marking Certification 1
RoHS Directive Compliant



KRF40A-V-01B

Features

- Safe and Environmentally Conscious...CE Marking Certified
- Quiet Operation...Noise level reduced by 3dB (compared with conventional models)
- Long Life...Increased 30% with newly developed vane blade material. (compared with conventional models)

Applications

- Vacuum source for printing machines, book binding, automated machines, packaging machines, etc.

Specifications

Single phase motor 3 phase motor

Model	Designed pumping capacity		Ultimate vacuum		Continuous operational vacuum		Continuous operational pressure		Suction/exhaust port dia.	Voltage						Standard motor current rating A				Noise level		Motor	Mass			
										Single phase (02)			3 phase (01B)			Single phase (02)		3 phase (01B)								
										100/200V		200V	220V		100V	200V	200V		220V							
										50/60Hz			60Hz			50/60Hz		60Hz								
								3 phase(04B)※5						3 phase(04B)※5												
L/min ※2		kPa※3		kPa※4		kPa※4				380V	400V	415V	400V	440V	460V	380V	400V	415V	400V	440V	460V	dB※6		kW	Single phase	3 phase
50Hz	60Hz	50Hz	60Hz	Recom.	Max.	Recom.	Max.	50Hz	50Hz	50Hz	60Hz	60Hz	60Hz	50Hz	50Hz	50Hz	60Hz	60Hz	60Hz	50Hz	60Hz					

KRF15A-□-□

V-01A	235	280	84	86	60	75	—	—	Rc 3/4	—	○	○	—	2.29/2.08	1.99	60	62	0.4	—	17
V-02	235	280	84	86	60	75	—	—	Rc 3/4	○	—	—	6.8/6.0	3.4/3.0	—	62	64	0.4	21	—
V-04	235	280	84	86	60	75	—	—	Rc 3/4	○	○	—	1.1	1.0	—	60	62	0.4	—	20
B-01A	235	280	—	—	—	—	60	70	Rc 3/4	—	○	○	—	2.29/2.08	1.99	64	65	0.4	—	17
B-02	235	280	—	—	—	—	60	70	Rc 3/4	○	—	—	6.8/6.0	3.4/3.0	—	64	65	0.4	21	—
B-04	235	280	—	—	—	—	60	70	Rc 3/4	○	○	○	1.1	1.0	—	64	65	0.4	—	20
VB-01A	235	280	—	—	Total: sugg. 60,max.75			—	Rc 3/4	—	○	○	—	2.29/2.08	1.99	60	62	0.4	—	17
VB-02	235	280	—	—	Total: sugg. 60,max.75			—	Rc 3/4	○	—	—	6.8/6.0	3.4/3.0	—	62	64	0.4	21	—
VB-04	235	280	—	—	Total: sugg. 60,max.75			—	Rc 3/4	○	○	○	1.1	1.0	—	60	62	0.4	—	20

KRF25A-□-□

V-01B	405	480	86	90	60	80	—	—	Rc 3/4	—	○	○	—	3.99/3.47	3.49	62	64	0.75	—	29
V-02	405	480	86	90	60	80	—	—	Rc 3/4	○	—	—	11.0/10.4	5.5/5.2	—	64	66	0.75	32	—
V-04B	405	480	86	90	60	80	—	—	Rc 3/4	○	○	○	2.0	1.9	1.7	62	64	0.75	—	34
B-01B	405	480	—	—	—	—	60	70	Rc 3/4	—	○	○	—	3.99/3.47	3.49	65	67	0.75	—	29
B-02	405	480	—	—	—	—	60	70	Rc 3/4	○	—	—	11.0/10.4	5.5/5.2	—	67	69	0.75	32	—
B-04B	405	480	—	—	—	—	60	70	Rc 3/4	○	○	○	2.0	1.9	1.7	65	67	0.75	—	34
VB-01B	405	480	—	—	Total: sugg. 60,max.80			—	Rc 3/4	—	○	○	—	3.99/3.47	3.49	62	64	0.75	—	29
VB-02	405	480	—	—	Total: sugg. 60,max.80			—	Rc 3/4	○	—	—	11.0/10.4	5.5/5.2	—	64	66	0.75	32	—
VB-04B	405	480	—	—	Total: sugg. 60,max.80			—	Rc 3/4	○	○	○	2.0	1.9	1.7	62	64	0.75	—	34

KRF40A-□-□

V-01B	575	685	86	90	60	80	—	—	Rc 3/4	—	○	○	—	5.19/4.71	4.57	66	67	1.1	—	35
V-04B	575	685	86	90	60	80	—	—	Rc 3/4	○	○	○	3.5	3.4	2.5	66	67	1.1	—	43
B-01B	575	685	—	—	—	—	60	70	Rc 3/4	—	○	○	—	5.19/4.71	4.57	68	70	1.1	—	35
B-04B	575	685	—	—	—	—	60	70	Rc 3/4	○	○	○	3.5	3.4	2.5	68	70	1.1	—	43
VB-01B	575	685	—	—	Total: sugg. 60,max.80			—	Rc 3/4	—	○	○	—	5.19/4.71	4.57	66	67	1.1	—	35
VB-04B	575	685	—	—	Total: sugg. 60,max.80			—	Rc 3/4	○	○	○	3.5	3.4	2.5	66	67	1.1	—	43

※1 Models with single phase motors and models without motors are excluded. ※2 Designed pumping capacity: Theoretical value calculated from cylinder volume. Refer to "Performance Data" for actual flow rate. ※3 Operation not allowed at ultimate vacuum. For model selection purposes only. ※4 Operable range of vacuum (pressure). ※5 "04" models are special order items. ※6 Operating noise measured on a new pump with an ORION recommended motor running at the recommended vacuum/pressure conditions. Operating noise levels are from a position of 1m in front of the unit and at a height of 1m. ※ Operating environment (inlet air) conditions: air temp: 0 ~ 40°C, humidity: normal levels (65±20%). ※ Allowable intermittent power supply voltage fluctuation range is ±10% of the specified voltage; allowable sustained supply voltage fluctuation range is ±5% of the specified voltage. ※ Please install an overload protection device (such as a thermal relay). ※ For detailed specifications, please refer to the specifications sheet.

Performance Data

(— 50Hz — 60Hz)

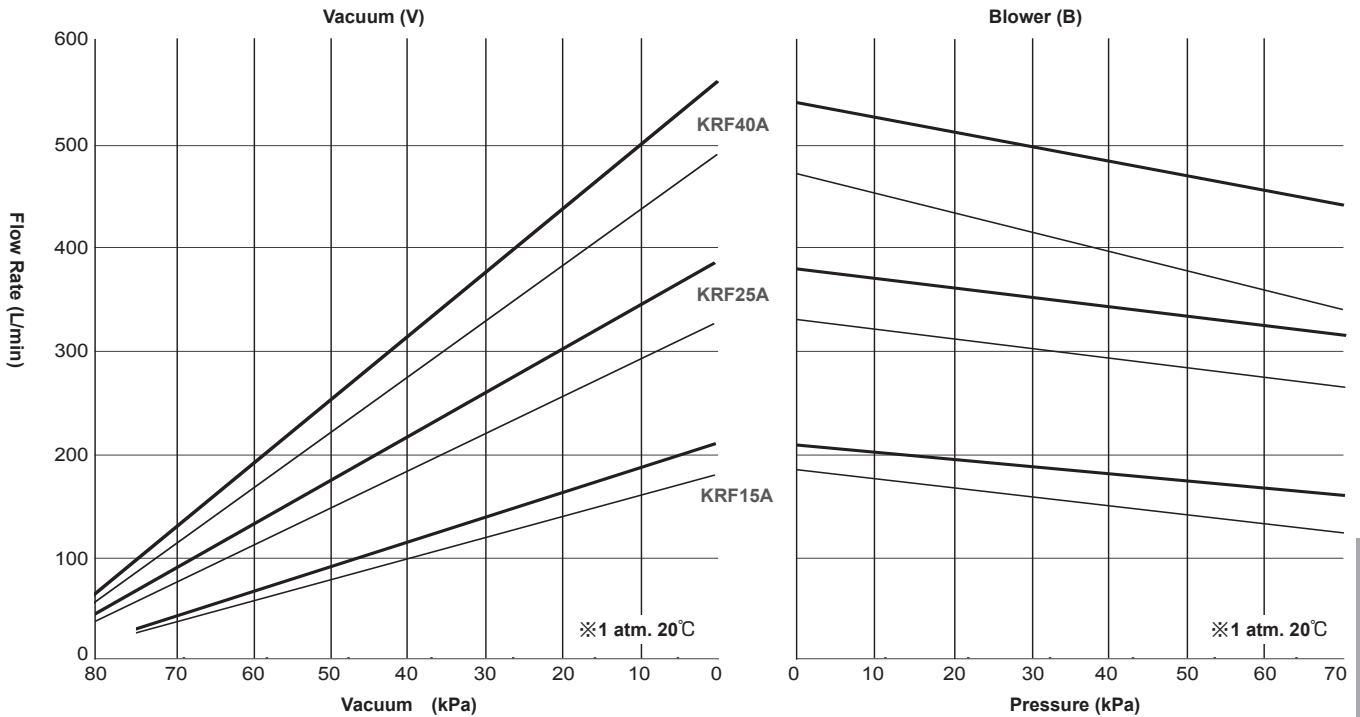

Outside Dimensions (Units:mm)

⋮ Indicates KRF 15A/25A-V-01B (3 phase, vacuum config.)

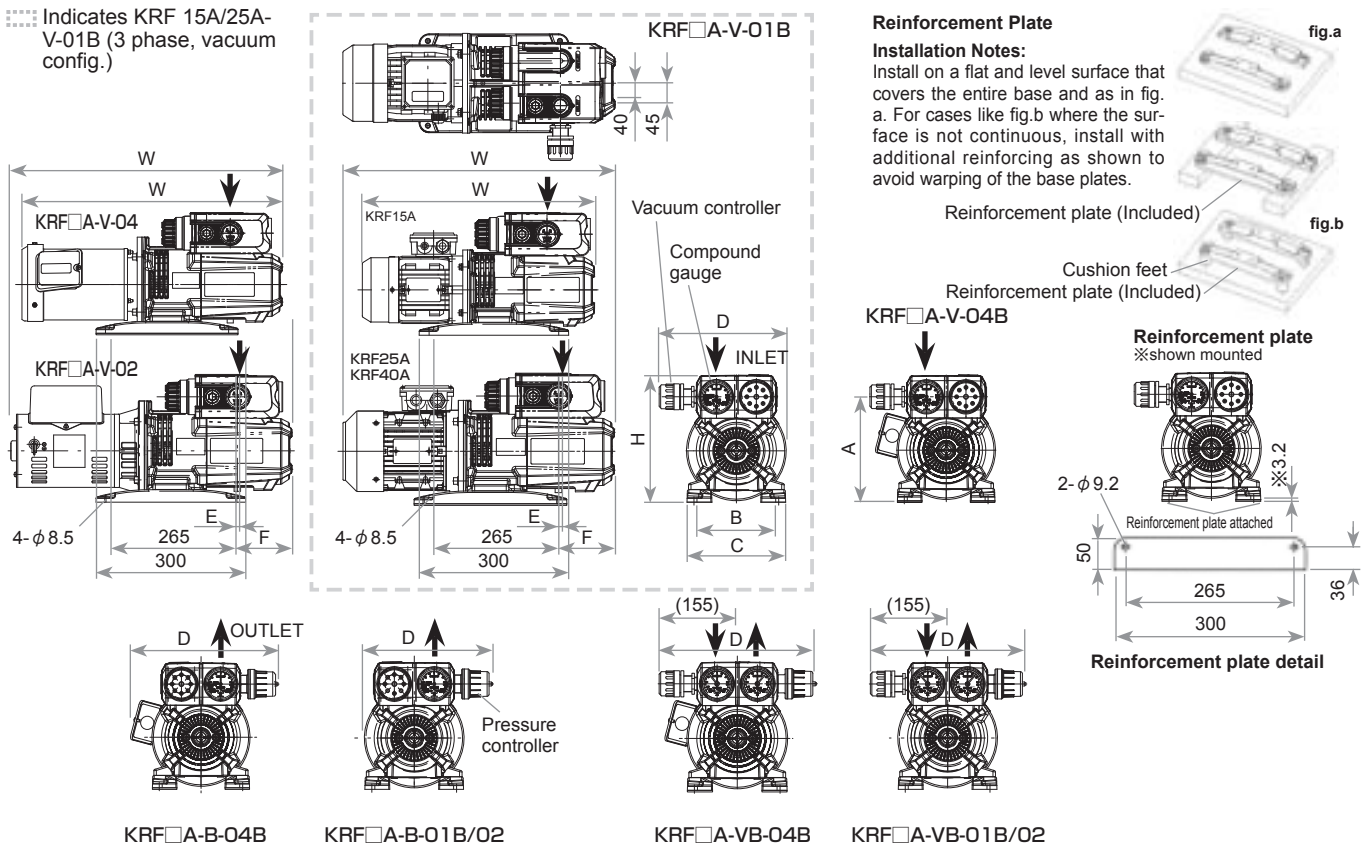

Model	H	D	W	A	B	C	E	F
KRF15A-V-01A, 02, 04	(248)	(249)	01A(466),02(484),04 (486)	(203)	160	188	(26)	(70)
KRF15A-B-01A, 02, 04	(248)	01A(251), 02(251), 04(291)	01A(466),02(484),04 (486)	(203)	160	188	(26)	(70)
KRF15A-VB-01A, 02, 04	(248)	(312)	01A(466),02(484),04(486)	(203)	160	188	(26)	(70)
KRF25A-V-01B, 02, 04B	(257)	(254)	01B(533),04B(533),02(564)	(212)	170	198	(1)	(111)
KRF25A-B-01B, 02, 04B	(257)	01B(258), 04B(314), 02(258)	01B(533),04B(533),02(564)	(212)	170	198	(1)	(111)
KRF25A-VB-01B, 02, 04B	(255)	(312)	01B(533),04B(533),02(564)	(212)	170	198	(1)	(111)
KRF40A-V-01B, 04B	(269)	(254)	01B(615),04B(615)	(224)	170	198	(43)	(167)
KRF40A-B-01B, 04B	(269)	(257)	01B(615),04B(615)	(224)	170	198	(43)	(167)
KRF40A-VB-01B, 04B	(269)	(312)	01B(615),04B(615)	(224)	170	198	(43)	(167)

Standard Pump
KRF Series



Standard KRF Series -- Heavy Duty Model

Safety Enhanced Design Low Noise Long Life Environmentally Friendly

Continuously Operational Vacuum
60kPa or less (V / B / VB)
Continuously Operational Pressure
80kPa or less (VH / BH / VBH)
Capacity
1350 ~ 2200 L/min (60Hz)
CE Marking Certification ※1
RoHS Directive Compliant



KRF70-V-01B

KRF110-V-01B

Features

- Safe and Environmentally Conscious..CE Marking Certified
- Quiet Operation...Noise level reduced by 3dB (compared with conventional models)
- Long Life...Increased 10% with newly developed vane blade material. (compared with conventional models)

Applications

Vacuum source for electronics and automotive manufacturing related facilities and equipment.
Vacuum source for printing equipment book making equipment packaging equipment automation equipment, etc.

Specifications

☐ 3 phase motor

Model	Designed pumping capacity		Ultimate vacuum	Continuously operational vacuum	Continuously operational pressure	Suction/exhaust port dia.	Voltage					Standard motor current rating A					Noise level	Motor	Mass
							3 phase(01B)					3 phase(01B)							
							200V		220V	200V		220V							
							50/60Hz		60Hz	50/50Hz		60Hz							
							3 phase(04B)※5					3 phase(04B)※5							
	L/min ※2		kPa (min.) ※3	kPa (max.) ※4	kPa (max.) ※4		380V	400V	415V	440V	460V	380V	400V	415V	440V	460V	dB※6	kW	kg
	50Hz	60Hz				50Hz	50/60Hz	50Hz	60Hz	60Hz	50Hz	50/60Hz	50Hz	60Hz	60Hz	50Hz			

KRF70-☐ - ☐

V-01B	1130	1350	90	60	—	Rc 1		○		○		10.6/10.0	9.6	67	68	2.2	94	
V-04B	1130	1350	90	60	—	Rc 1	—	○	—	○	○	5.3/5.0	4.8	4.8	67	68	2.2	94
VH-01B	1130	1350	90	80	—	Rc 1		○		○		10.6/10.0	9.6	73	74	2.2	94	
VH-04B	1130	1350	90	80	—	Rc 1	—	○	—	○	○	5.3/5.0	4.8	4.8	73	74	2.2	94
B-01B	1130	1350	—	—	60	Rc 1		○		○		10.6/10.0	9.6	74	76	2.2	94	
B-04B	1130	1350	—	—	60	Rc 1	—	○	—	○	○	5.3/5.0	4.8	4.8	74	76	2.2	94
BH-01B	1130	1350	—	—	70	Rc 1		○		○		10.6/10.0	9.6	74	76	2.2	94	
BH-04B	1130	1350	—	—	70	Rc 1	—	○	—	○	○	5.3/5.0	4.8	4.8	74	76	2.2	94
VB-01A	1130	1350	—	60 or less altogether		Rc 1		○		○		10.6/10.0	9.6	67	68	2.2	94	
VB-04B	1130	1350	—	60 or less altogether		Rc 1	—	○	—	○	○	5.3/5.0	4.8	4.8	67	68	2.2	94
VBH-01B	1130	1350	—	80 or less altogether		Rc 1		○		○		10.6/10.0	9.6	73	74	2.2	94	
VBH-04B	1130	1350	—	80 or less altogether		Rc 1	—	○	—	○	○	5.3/5.0	4.8	4.8	73	74	2.2	94

KRF110-☐ - ☐

V-01B	1850	2200	90	60	—	Rc 1 1/4		○		○		16.6/15.6	14.8	74	75	3.7	131			
V-04B	1850	2200	90	60	—	Rc 1 1/4	○	○	○	○	○	8.5	8.3/7.8	8.3	7.4	7.4	74	75	3.7	131
B-01B	1850	2200	—	—	60	Rc 1 1/4		○		○		16.6/15.6	14.8	76	77	3.7	131			
B-04B	1850	2200	—	—	60	Rc 1 1/4	○	○	○	○	○	8.5	8.3/7.8	8.3	7.4	7.4	76	77	3.7	131
VB-01B	1850	2200	—	60 or less altogether		Rc 1 1/4		○		○		16.6/15.6	14.8	74	75	3.7	131			
VB-04B	1850	2200	—	60 or less altogether		Rc 1 1/4	○	○	○	○	○	8.5	8.3/7.8	8.3	7.4	7.4	74	75	3.7	131

※1 Models without motors are excluded. ※2 Designed pumping capacity: Theoretical value calculated from cylinder volume. Refer to "Performance Data" for actual flow rate. ※3 Operation not allowed at ultimate vacuum. For model selection purposes only. ※4 Operable range of vacuum (pressure). ※5 "04" models are special order items. ※6 Operating noise measured on a new pump with an ORION recommended motor running at the recommended vacuum/pressure conditions. Operating noise levels are from a position of 1m in front of the unit and at a height of 1m. ※ Operating environment (inlet air) conditions: air temp: 0 ~ 40°C, humidity: normal levels (65±20%). ※ Allowable intermittent power supply voltage fluctuation range is ±10% of the specified voltage; allowable sustained supply voltage fluctuation range is ±5% of the specified voltage. ※ Please install an overload protection device (such as a thermal relay). ※ For detailed specifications, please refer to the specifications sheet.

Performance Data

(— 50Hz — 60Hz)

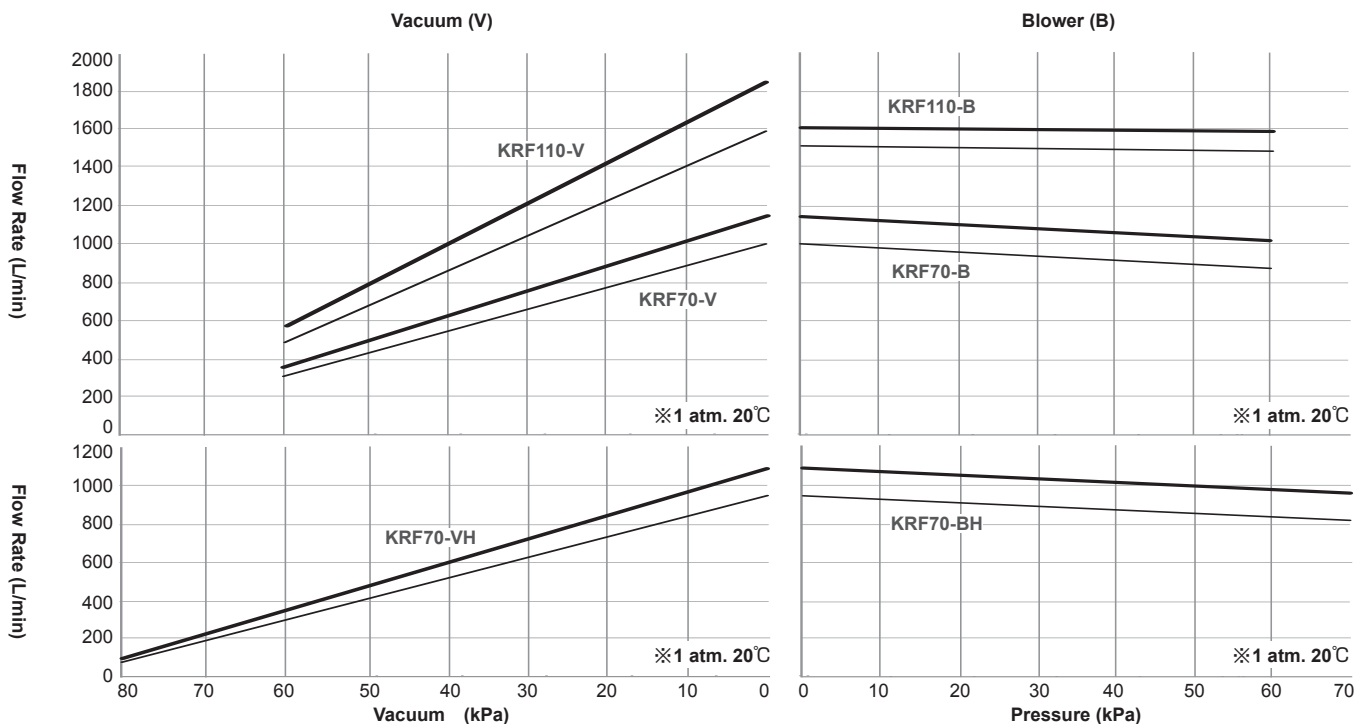

Outside Dimensions (unit:mm)

- KRF70-V-01B,04B
 - KRF70-VH-01B,04B
 - KRF70-B-01B,04B
 - KRF70-BH-01B,04B
 - KRF70-VB-01B,04B
 - KRF70-VBH-01B,04B
- ※Diagrams are for vacuum configuration.

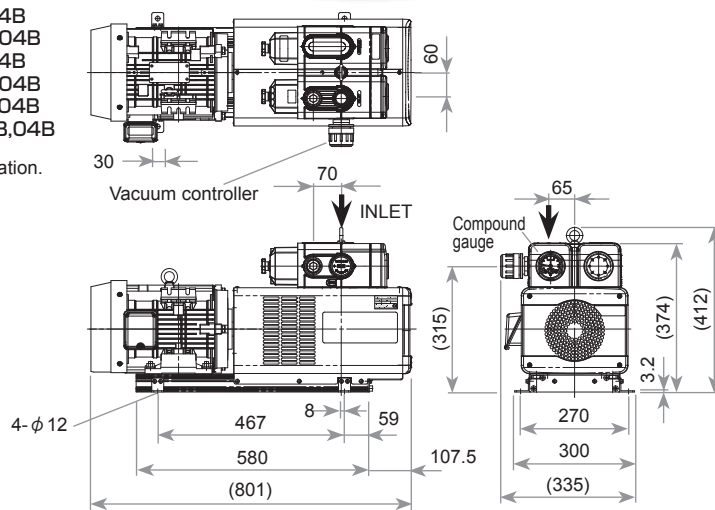

- KRF110-V-01B,04B
 - KRF110-B-01B,04B
 - KRF110-VB-01B,04B
- ※Diagrams are for vacuum configuration.

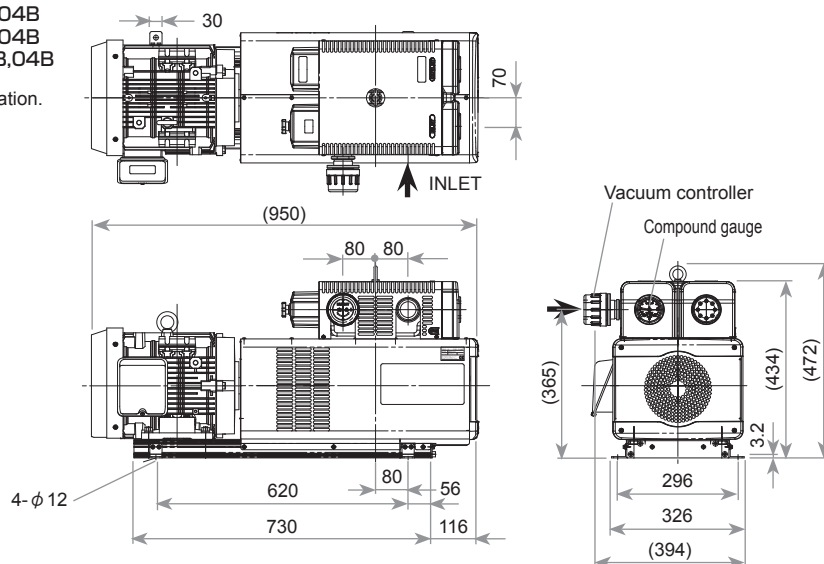

Standard Pump
KRF Series - - Heavy Duty Model



Combination Pump CBF Series

Safety Enhanced Design • Low Noise • Long Life • Environmentally Friendly

Continuous Operational Vacuum
 Recomm. 60kPa or less (V Type)
Continuous Operational Pressure
 Recomm. 60kPa or less (B Type)
Continuous Operational Vacuum & Pressure
 Total Combined Vacuum & Pressure 60kPa or less (VB Type)
Capacity
 280685 L/min (60Hz)
RoHS Directive Compliant
CE Marking Certification※1

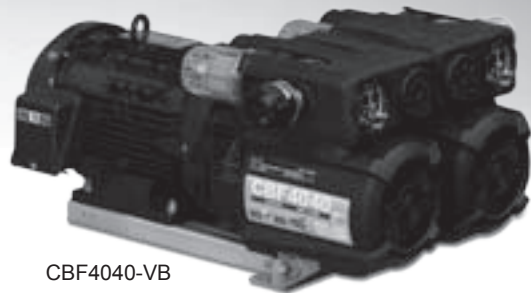

CBF4040-VB

Features

Safe and Environmentally Conscious...CE Marking Certified RoHS Directive Compliant
Quiet Operation...Noise level reduced by 3dB (compared with conventional models)
Long Life...Increased 30% with newly developed vane blade material (compared with conventional models).

Applications

● **Vacuum source for printing equipment • book making equipment • packaging equipment • automation equipment, etc.**

Specifications

Model	Designed pumping capacity				Continu-ous opera-tional vacuum	Continu-ous opera-tional pressure	Continuous combined operational vacuum & pressure		Suction exhaust port diameter	Voltage					Standard motor current rating A					Noise level	Motor Three-phase (01) 200V, (04) 400V	Mass						
										3 phase(01B)		3 phase(01B)			3 phase(04B)※3								3 phase(04B)※3					
	200V		220V							200V		220V																
	50/60Hz		60Hz							50/50Hz		60Hz																
L/min ※1				kPa (max.) ※2	kPa (max.) ※2	kPa			3 phase(04B)※3					3 phase(04B)※3					dB※4	kW	kg							
Pump 1		Pump 2							380V 400V 415V 440V 460V					380V 400V 415V 440V 460V														
50Hz		60Hz		50Hz		60Hz		Recom.	Max.	50Hz	50/60Hz	50Hz	60Hz	60Hz	50Hz	50/60Hz	50Hz	60Hz	60Hz	50Hz	60Hz							

CBF1515- □ - □

VB-01B	235(V)	280(V)	235(B)	280(B)	60	60	—	—	Rc3/4	○	○	○	○	○	3.8/3.4	3.4	62	63	0.75	37			
VB-04B	235(V)	280(V)	235(B)	280(B)	60	60	—	—	Rc3/4	○	○	○	○	○	2.0	1.9/1.7	1.9	1.7	1.7	62	63	0.75	37
VBVB-01B	235(V,B)	280(V,B)	235(V,B)	280(V,B)	—	—	—	—	Rc3/4	○	○	○	○	○	3.8/3.4	3.4	65	66	0.75	37			
VBVB-04B	235(V,B)	280(V,B)	235(V,B)	280(V,B)	—	—	※5	※6	Rc3/4	○	○	○	○	○	2.0	1.9/1.7	1.9	1.7	1.7	65	66	0.75	37
VV-01B	235(V)	280(V)	235(V)	280(V)	60	—	—	—	Rc3/4	○	○	○	○	○	3.8/3.4	3.4	61	62	0.75	37			
BB-01B	235(B)	280(B)	235(B)	280(B)	—	60	—	—	Rc3/4	○	○	○	○	○	3.8/3.4	3.4	65	66	0.75	37			

CBF2525- □ - □

VB-01B	405(V)	480(V)	405(B)	480(B)	60	60	—	—	Rc3/4	○	○	○	○	○	6.8/6.4	6.0	64	67	1.5	52			
VB-04B	405(V)	480(V)	405(B)	480(B)	60	60	—	—	Rc3/4	○	○	○	○	○	3.5	3.4/3.2	3.4	3.0	3.0	64	67	1.5	52
VBVB-01B	405(V,B)	480(V,B)	405(V,B)	480(V,B)	—	—	—	—	Rc3/4	○	○	○	○	○	6.8/6.4	6.0	67	70	1.5	52			
VBVB-04B	405(V,B)	480(V,B)	405(V,B)	480(V,B)	—	—	※5	※6	Rc3/4	○	○	○	○	○	3.5	3.4/3.2	3.4	3.0	3.0	67	70	1.5	52
VV-01B	405(V)	480(V)	405(V)	480(V)	60	—	—	—	Rc3/4	○	○	○	○	○	6.8/6.4	6.0	63	66	1.5	52			
BB-01B	405(B)	480(B)	405(B)	480(B)	—	60	—	—	Rc3/4	○	○	○	○	○	6.8/6.4	6.0	67	70	1.5	52			

CBF4040- □ - □

VB-01B	575(V)	685(V)	575(B)	685(B)	60	60	—	—	Rc3/4	○	○	○	○	○	10.6/9.4	9.2	68	70	2.2	67			
VB-04B	575(V)	685(V)	575(B)	685(B)	60	60	—	—	Rc3/4	○	○	○	○	○	5.3	5.3/4.7	5.4	4.6	4.6	68	70	2.2	67
VBVB-01B	575(V,B)	685(V,B)	575(V,B)	685(V,B)	—	—	—	—	Rc3/4	○	○	○	○	○	10.6/9.4	9.2	69	71	2.2	67			
VBVB-04B	575(V,B)	685(V,B)	575(V,B)	685(V,B)	—	—	※5	※6	Rc3/4	○	○	○	○	○	5.3	5.3/4.7	5.4	4.6	4.6	69	71	2.2	67
VV-01B	575(V)	685(V)	575(V)	685(V)	60	—	—	—	Rc3/4	○	○	○	○	○	10.6/9.4	9.2	67	69	2.2	67			
BB-01B	575(V)	685(B)	575(B)	685(B)	—	60	—	—	Rc3/4	○	○	○	○	○	10.6/9.4	9.2	71	73	2.2	67			

※1 Designed pumping capacity: Theoretical value calculated from cylinder volume. Refer to "Performance Data" for actual flow rate. ※2 Operable range of vacuum (pressure). ※3 "04" models are special order items. ※4 Operating noise measured on a new pump with an ORION recommended motor running at normal vacuum/pressure conditions. Operating noise levels are from a position of 1m in front of the unit and at a height of 1m. ※5 Recommended range of combined vacuum and pump pressures: 60 or lower. ※6 Maximum vacuum/pressure per pump can be any combination of the following (vacuum/pressure): 55/20, 55/30, 40/40, 35/50. The maximum vacuum/pressure of the dry pump indicates the maximum sustainable vacuum/pressure. Do not operate the pump beyond this maximum value. Doing so can reduce the lifespan of the pump and may result in breakdown or an accident. ※ Please consult with your dealer regarding operation in extremely dry environments, as doing so may lead to pump damage. ※ Allowable intermittent power supply voltage fluctuation range is ±10% of the specified voltage; allowable sustained supply voltage fluctuation range is ±5% of the specified voltage. ※ When using other than the ORION standard motor, follow the electrical guidelines printed on the nameplate of the motor used. ※ Please install an overload protection device (such as a thermal relay). ※ For detailed specifications, please refer to the specifications sheet.

Performance Data

(— 50Hz — 60Hz)

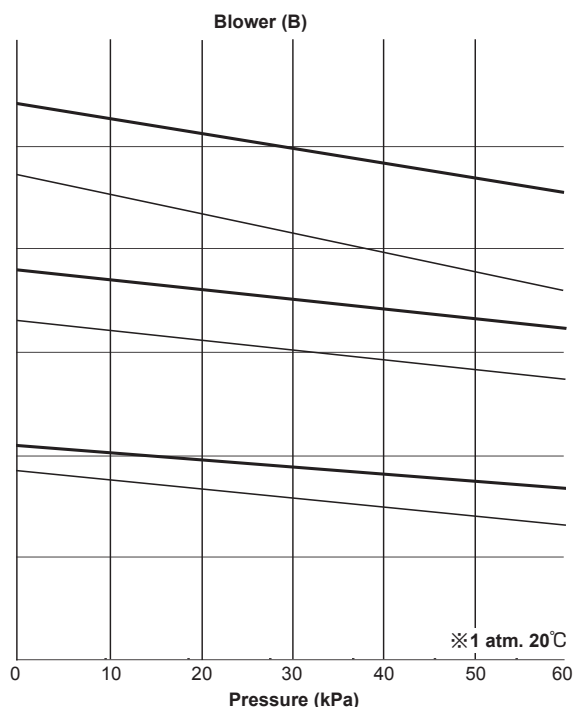
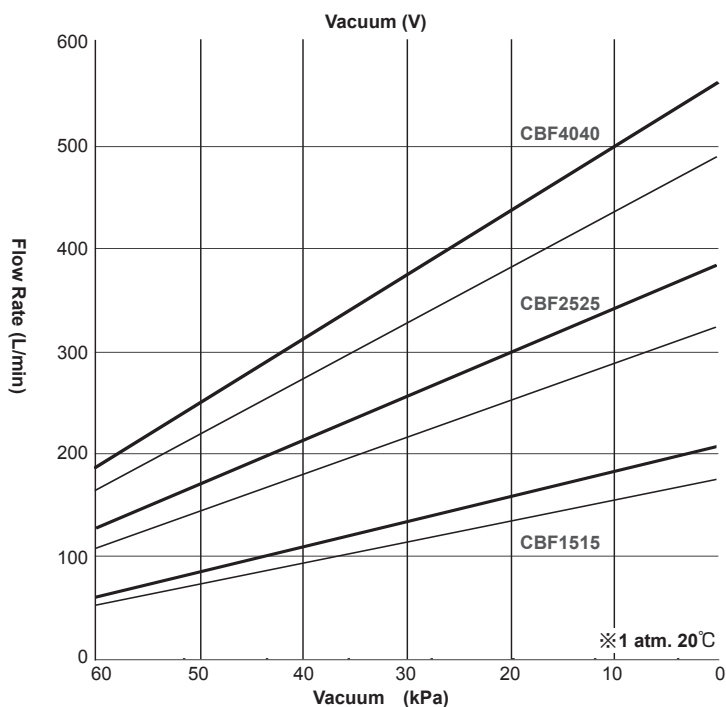

Outside Dimensions (Units:mm)

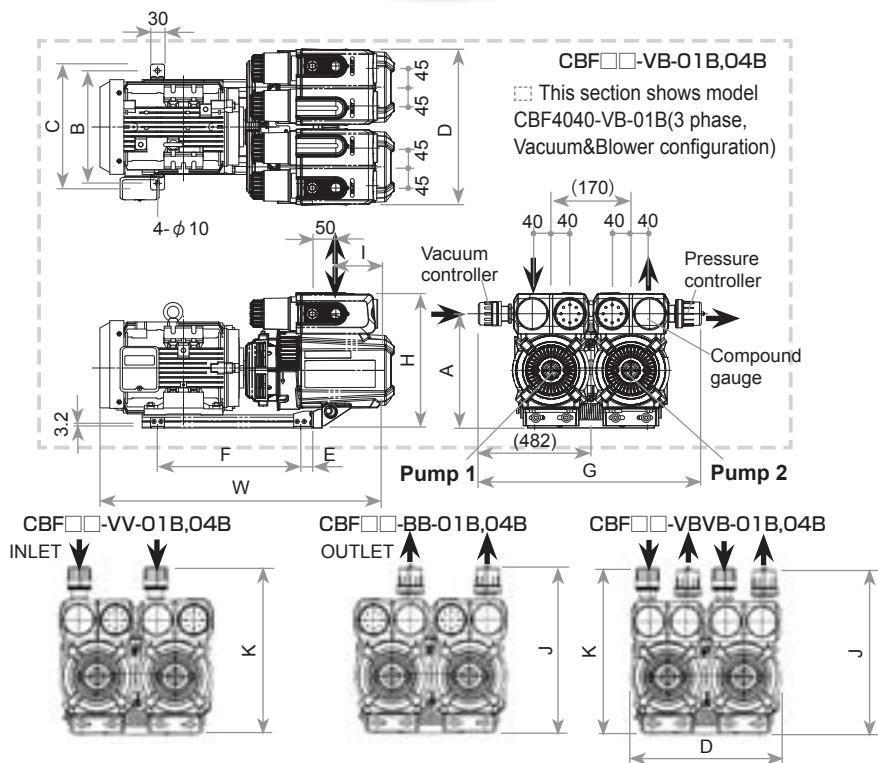

Model	H	D	W	A	B	C	E	F	G	I	J	K
CBF1515-VB-01B,04B	(269)	(331)	(483)	224	205	233	15	225	(482)	(95)	—	—
CBF1515-VBVB-01B,04B	(267)	(331)	(483)	224	205	233	15	225	—	(95)	(343)	(341)
CBF1515-VV-01B	(269)	(335)	(483)	224	205	233	15	225	—	(95)	—	(341)
CBF1515-BB-01B	(269)	(335)	(483)	224	205	233	15	225	—	(95)	(343)	—
CBF2525-VB-01B,04B	(276)	(331)	(558)	231	220	248	15	270	(482)	(109)	—	—
CBF2525-VBVB-01B,04B	(274)	(331)	(558)	231	220	248	15	270	—	(109)	(350)	(348)
CBF2525-VV-01B	(276)	(335)	(558)	231	220	248	15	270	—	(109)	—	(348)
CBF2525-BB-01B	(276)	(335)	(558)	231	220	248	15	270	—	(109)	(350)	—
CBF4040-VB-01B,04B	(288)	(334)	(627)	244	240	268	25	305	(482)	(124)	—	—
CBF4040-VBVB-01B,04B	(286)	(334)	(627)	244	240	268	25	305	—	(124)	(363)	(361)
CBF4040-VV-01B	(288)	(335)	(627)	244	240	268	25	305	—	(124)	—	(361)
CBF4040-BB-01B	(288)	(335)	(627)	244	240	268	25	305	—	(124)	(363)	—

Combination Pump
CBF Series



Combination Pump CBX62,62A

Continuous Operative Vacuum: 60kPa or less

(CBX-□ -01B not included)

Continuous Operative Pressure: 60kPa or less

(CBX□ -□ -01B not included)

Flow Capacity: 1115 L/min (60Hz)



CBX62-01B-G1

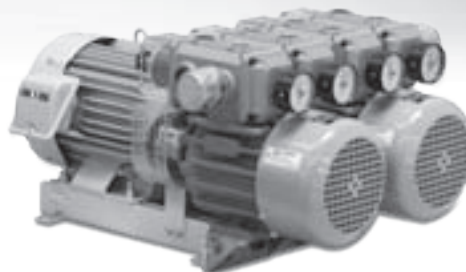

CBX62-A-01B-G1

Features

- 2 cylinder (vacuum and pressure) design allows simultaneous vacuum and pressure operation for individual vacuum and pump pressures below 60kPa.
- Compared with existing Orion models, the CBX line offers smaller size and lighter weight in an easy to use package.

Specifications

Model	Designed pumping capacity				Continuous operational vacuum	Continuous operational pressure	Vacuum/pressure port diameter	Motor Voltage		Standard motor current rating		Noise level		Motor	Mass		
	L/min ※1							kPa (max.) ※2	kPa (max.) ※2	3 phase		3 phase				dB ※3	
	Pump 1		Pump 2							A		A				50Hz 60Hz	
	50Hz	60Hz	50Hz	60Hz						200V	220V	200V	220V			3 phase	
50/60Hz	60Hz	50/60Hz	60Hz			50/60Hz	60Hz					3 phase					
CBX□ -01B-□ (V,B specifications)																	
62-01B-G1	935	1115	935	1115	60	60	Rc 1	○	○	15.4/14.4	13.6	78	79	3.7	112		
CBX□ -A-01B-□ (VB,VB specifications)																	
62-A-01B-G1	935	1115	935	1115	55/35 ※4	20/50 ※4	Rc 1	○	○	15.4/14.4	13.6	—	—	3.7	112		

※1 Designed pumping capacity: Theoretical value calculated from cylinder volume. Refer to "Performance Data" for actual flow rate. ※2 Operable range of vacuum (pressure). ※3 Operating noise measured on a new pump with an ORION recommended motor running at normal vacuum/pressure conditions. Operating noise levels are from a position of 1m in front of the unit and at a height of 1m. ※4 Maximum combined output per cylinder (max. vacuum/max. pressure): Pump 1: (55 or lower/20 or lower), Pump 2: (35 or lower/50 or lower.) ※ Operating environment (inlet air) conditions: air temp: 0 ~ 40°C, humidity: normal levels (65±20%). ※ Allowable intermittent power supply voltage fluctuation range is ±10% of the specified voltage; allowable sustained supply voltage fluctuation range is ±5% of the specified voltage. ※ Please install an overload protection device (such as a thermal relay). ※ For detailed specifications, please refer to the specifications sheet.

Performance Data

(— 50Hz — 60Hz)

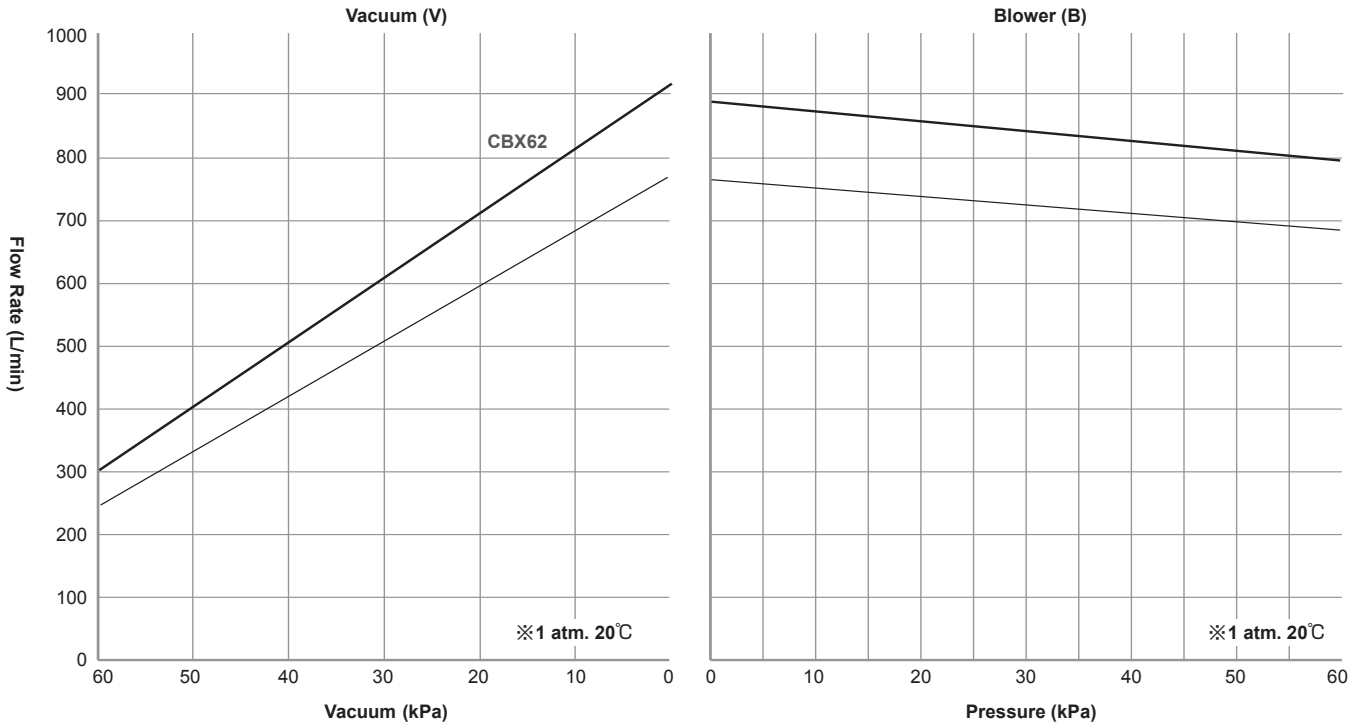

Outside Dimensions (Units:mm)

CBX62-01B-G1
CBX62-A-01B-G1

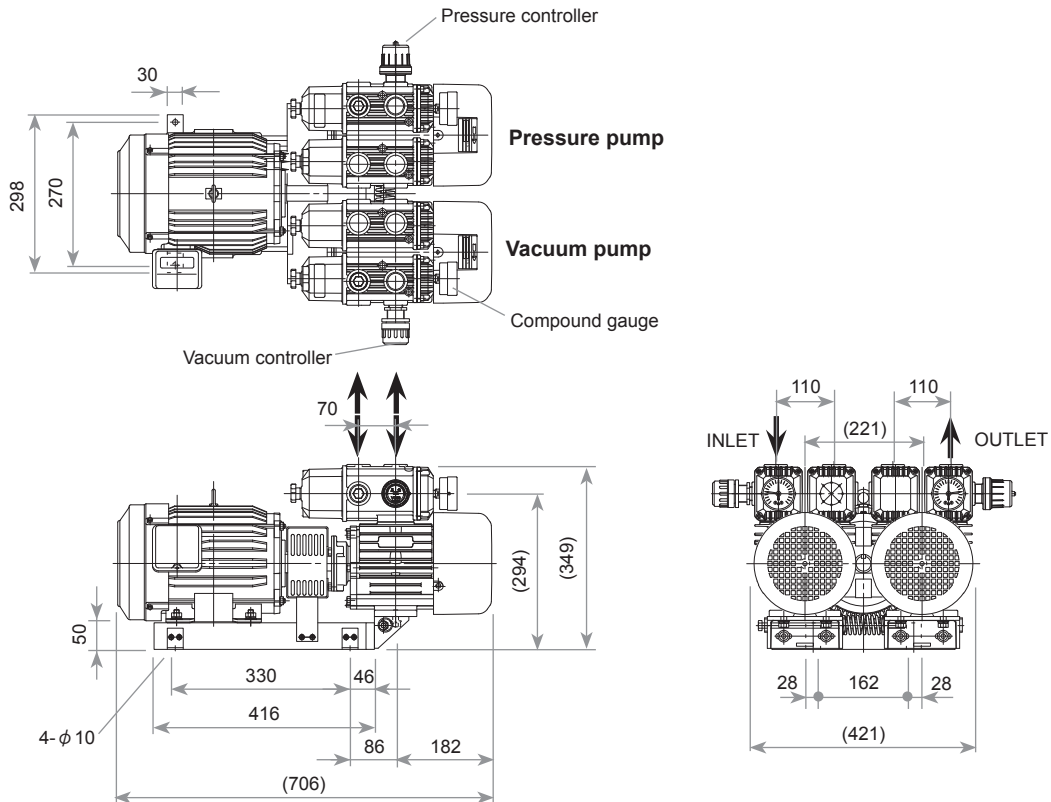

Combination Pump
CBX62



Combination Package CBXP Series

- Continuous Operative Vacuum: 60kPa or less
 (CBXP A-VB-02B/VV-02B)
 (CBXP B-VB-02B,03B/VV-02B,03B)
- Continuous Operative Pressure: 80kPa or less
 80kPa or less (CBXP A-VB-02B)
 70kPa or less (CBXP B-VB-02B,03B)
 60kPa or less (CBXP A-BB-02B, CBXP B-BB-02B,03B)
- Flow Rate: 1115 ~ 2200 L/min (60Hz)

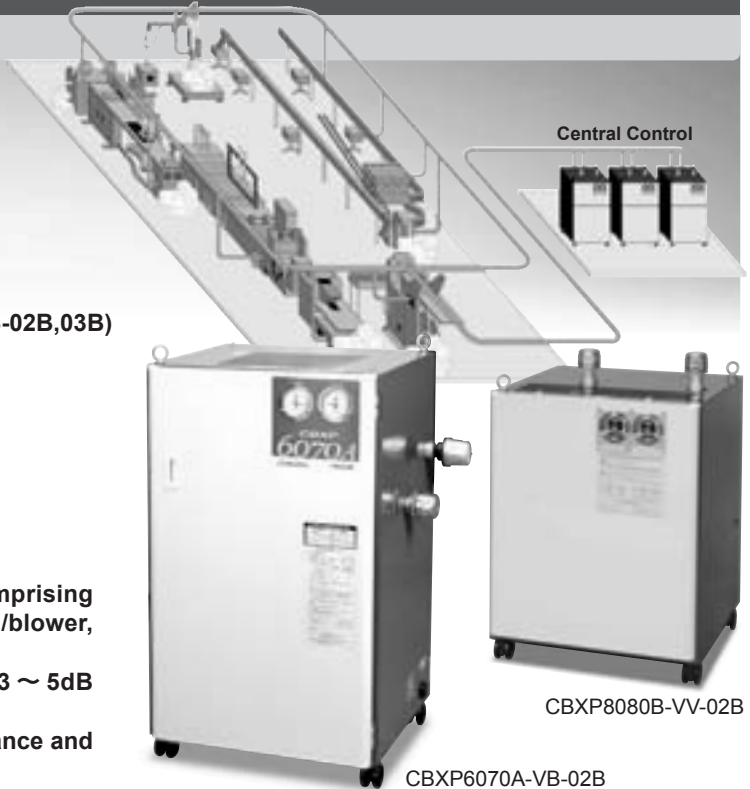

Features

- Many configurations available. 19 models comprising various combinations such as vacuum, vacuum/blower, blower/blower available.
- Lower operating noise Noise levels reduced 3 ~ 5dB compared with our earlier models.
- A standard sized pump that boasts good performance and improved maintenance characteristics.

Specifications

Model	Designed pumping capacity				Continuous operational vacuum		Continuous operational pressure		Inlet/outlet port diameter		Voltage	Standard motor current rating A	Noise level		Motor	Mass
	L/min ※2				kPa (max.) ※3		kPa (max.) ※3						dB ※4			
	Pump 1		Pump 2		Pump 1	Pump 2	Pump 1	Pump 2	Inlet	Outlet	3 phase	3 phase	50Hz	60Hz		3 phase
	50Hz	60Hz	50Hz	60Hz							200V	200V				
CBXP <input type="checkbox"/> - <input type="checkbox"/> - <input type="checkbox"/> ※1 (Vacuum (V) [Pump 1]) (Blower (B) [Pump 2])																
6070A-VB-02B	935	1115	1160	1380	60	—	—	80	R1	R1	○	22.6/20.8	73	76	5.5	177
8080B-VB-02B,03B	1315	1545	1370	1650	60	—	—	70	R1	R1 1/4	○	29.6/28	76	78	7.5	260
90110B-VB-02B,03B	1500	1800	1850	2200	60	—	—	70	R1 1/4	R1 1/4	○	29.6/28	79	81	7.5	305
CBXP <input type="checkbox"/> - <input type="checkbox"/> - <input type="checkbox"/> ※1 (Vacuum (V) [Pump 1]) (Vacuum (V) [Pump 2])																
6060A-VV-02B	935	1115	935	1115	60	60	—	—	R1	R1	○	15.4/14.4	72	73	3.7	147
8080B-VV-02B,03B	1315	1545	1315	1545	60	60	—	—	R1	R1	○	22.6/20.8	72	74	5.5	192
9090B-VV-02B,03B	1500	1800	1500	1800	60	60	—	—	R1 1/4	R1 1/4	○	22.6/20.8	75	77	5.5	272
110110B-VV-02B,03B	1850	2200	1850	2200	60	60	—	—	R1 1/4	R1 1/4	○	29.6/28	77	79	7.5	280
CBXP <input type="checkbox"/> - <input type="checkbox"/> - <input type="checkbox"/> ※1 (Blower (B) [Pump 1]) (Blower (B) [Pump 2])																
6060A-BB-02B	935	1115	935	1115	—	—	60	60	R1	R1	○	15.4/14.4	76	79	3.7	147
8080B-BB-02B,03B	1315	1545	1315	1545	—	—	60	60	R1	R1	○	22.6/20.8	74	78	5.5	192
9090B-BB-02B,03B	1500	1800	1500	1800	—	—	60	60	R1 1/4	R1 1/4	○	22.6/20.8	78	80	5.5	272
110110B-BB-02B,03B	1850	2200	1850	2200	—	—	60	60	R1 1/4	R1 1/4	○	29.6/28	80	81	7.5	280

※1 CBXP A--02B and CBXP B--02B models are equipped with casters. CBXP B--03 models are equipped with casters and an hour meter. ※2 Designed pumping capacity: Theoretical value calculated from cylinder volume. Refer to "Performance Data" for actual flow rate. ※3 Operable range of vacuum (pressure). ※4 Operating noise measured on a new pump with an ORION recommended motor running at normal vacuum/pressure conditions. Operating noise levels are from a position of 1m in front of the unit and at a height of 1m. ※ Operating environment (inlet air) conditions: air temp: 0 ~ 40°C, humidity: normal levels (65±20%). ※ Allowable intermittent power supply voltage fluctuation range is ±10% of the specified voltage; allowable sustained supply voltage fluctuation range is ±5% of the specified voltage. ※ Please install an overload protection device (such as a thermal relay). ※ To ensure proper pump ventilation, make sure there is at least 300mm clearance between the pump and walls, and at least 1000mm clearance between the top of the pump and the ceiling. ※ In order to allow for pump maintenance, maintain an open space at least 500mm from the front face of the unit. ※ For detailed specifications, please refer to the specifications sheet.

Performance Data

(— 50Hz — 60Hz)

CBXP □□□□ A-VB-02B、CBXP □□□□ B-VB-02B,03B

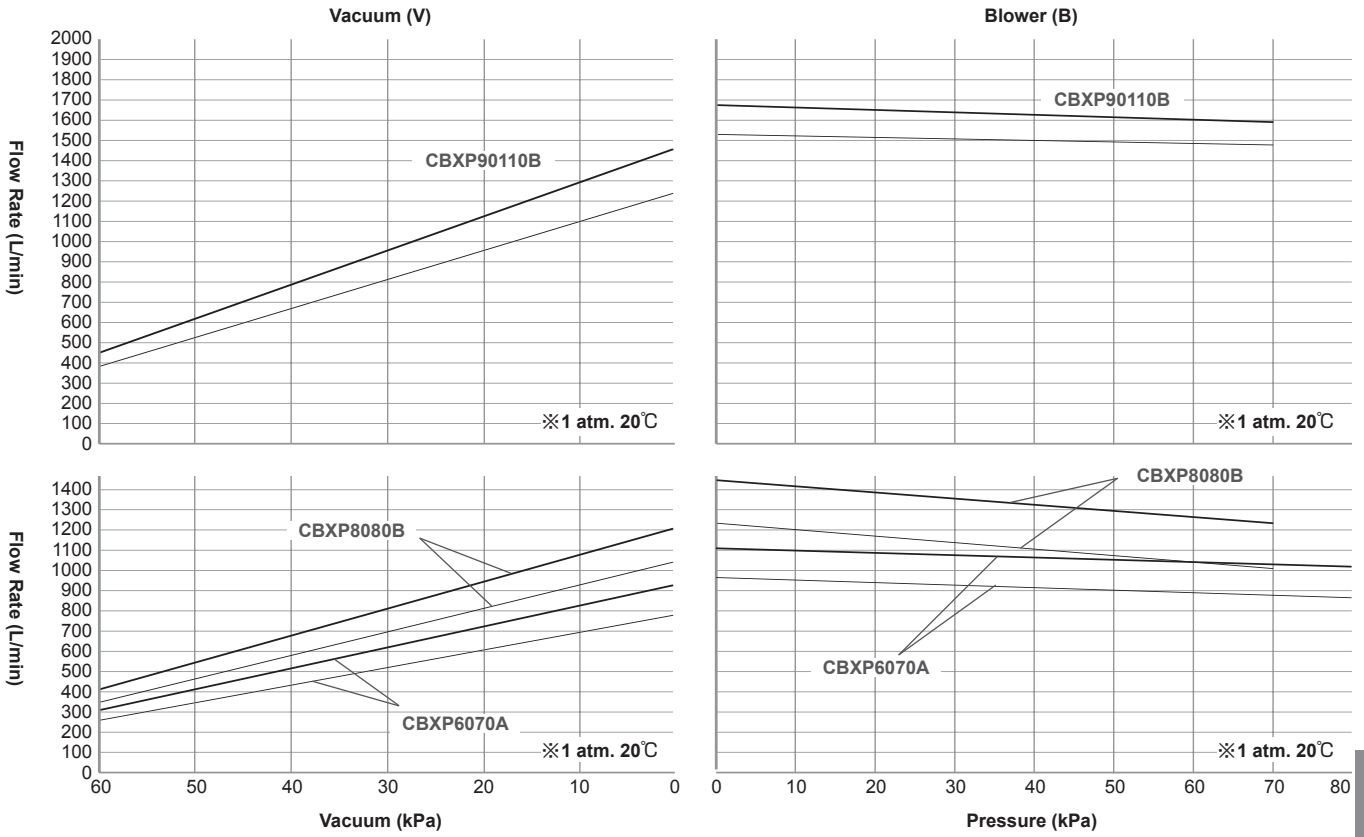

CBXP □□□□ A-VV-02B、CBXP □□□□ B-VV-02B,03B

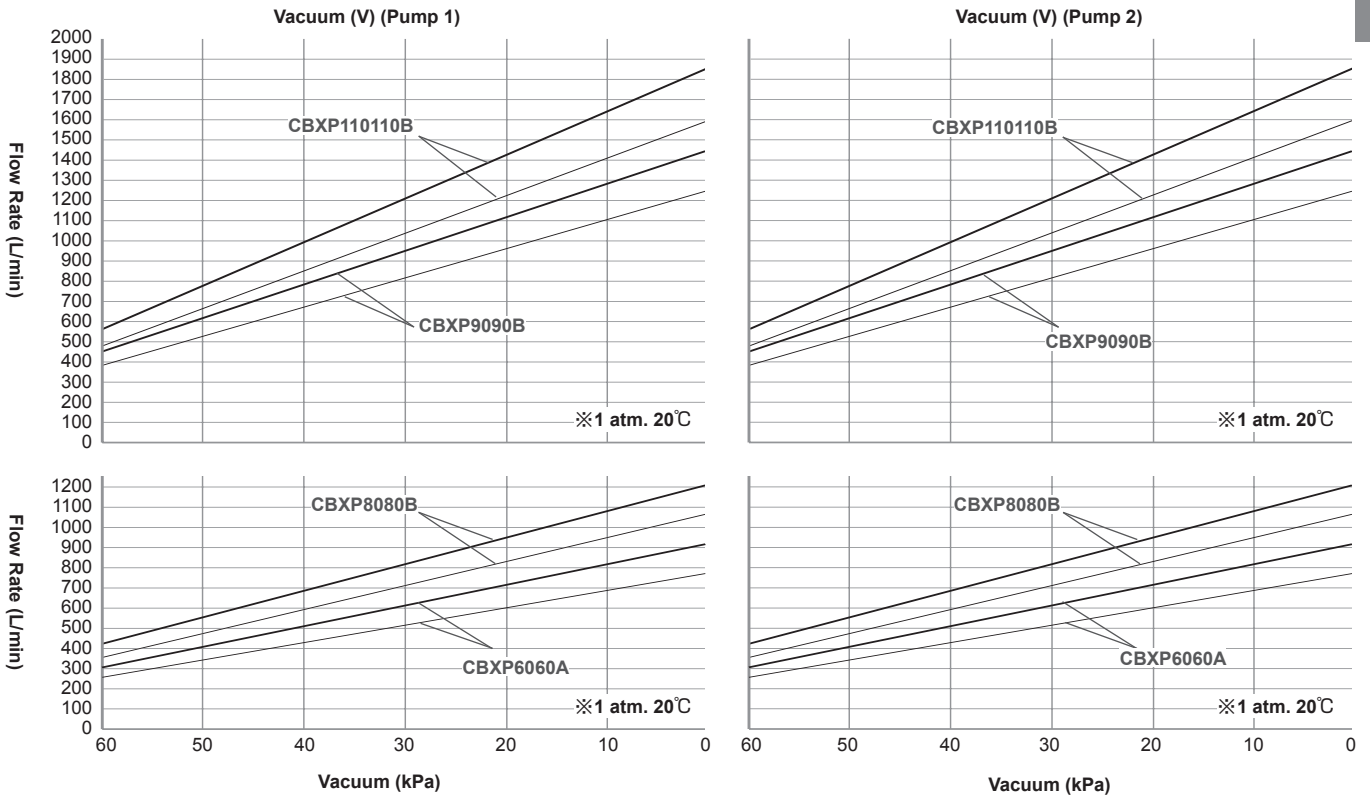

Combination Package
CBXP Series



Combination Package CBXP Series

Performance Data

(— 50Hz — 60Hz)

CBXP □□□□ A-BB-02B、CBXP □□□□ B-BB-01B,03B

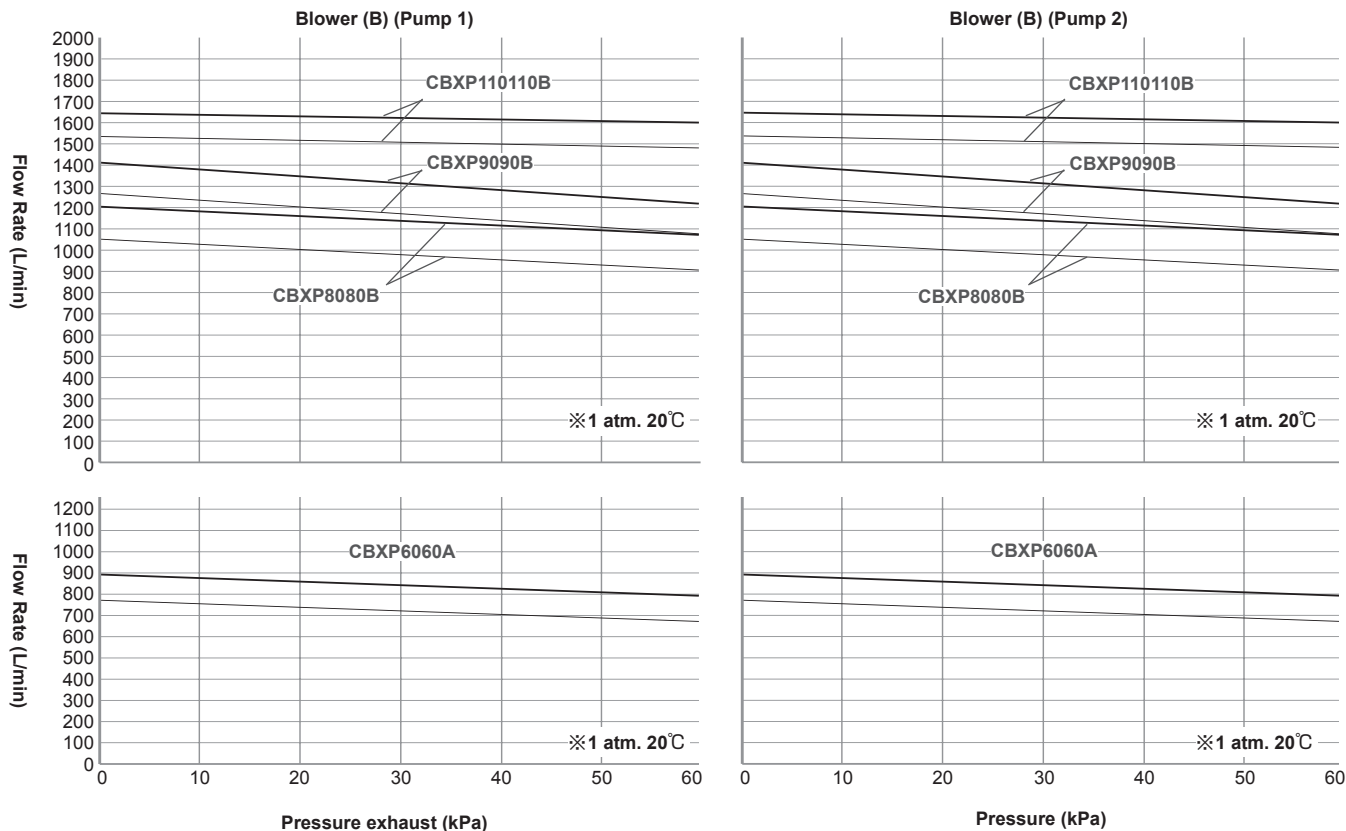

Outside Dimensions (Units:mm)

Model	H	D	W	A	B	C	E	F	G
CBXP6070A-VB-02B	890	533	560	(26)	(65)	(253)	(190)	(235)	(600)
CBXP8080B-VB-02B,03B	928	536	680	(11)	(89)	(261)	(233)	(225)	(616)
CBXP90110B-VB-02B,03B	967	565	730			(303)	(191)	(229)	(653)
CBXP6060A-VV-02B				(280)	(90)	(236)	(15)	(128)	(607)
CBXP8080B-VV-02B,03B	684	532	560	(293)	(74)	(232)	(19)	(93)	(620)
CBXP9090B-VV-02B,03B		565				(265)			(630)
CBXP110110B-VV-02B,03B	750	583	730	(390)	(100)	(364)	(38)	(105)	(627)
CBXP6060A-BB-02B				(280)	(190)	(236)	(15)	(128)	(607)
CBXP8080B-BB-02B,03B	684	532	560	(293)	(194)	(232)	(19)	(93)	(620)
CBXP9090B-BB-02B,03B		565				(264)			(630)
CBXP110110B-BB-02B,03B	750	583	730	(390)	(240)	(364)	(38)	(105)	(627)

Model	I	J	K	L	M	N	O	P	Q	R
CBXP6070A-VB-02B	(1000)	510	(671)	450	86.2	(65)	42	(98)	(621)	(98)
CBXP8080B-VB-02B,03B	(1051)	610	(794)	451	157	(78)	61	(109)	(672)	(109)
CBXP90110B-VB-02B,03B	(1090)	660	(843)	480			61	(94)	(722)	(94)
CBXP6060A-VV-02B	(836)				86					
CBXP8080B-VV-02B,03B	(862)	510	—	450	137	(65)	42	—	—	—
CBXP9090B-VV-02B,03B	(939)									
CBXP110110B-VV-02B,03B	(930)	660	—	480	157	(78)	61	—	—	—
CBXP6060A-BB-02B	(843)				86					
CBXP8080B-BB-02B,03B	(869)	510	—	450	137	(65)	42	—	—	—
CBXP9090B-BB-02B,03B	(954)									
CBXP110110B-BB-02B,03B	(945)	660	—	480	157	(78)	61	—	—	—

CBXP8080B-VB-02B,03B
 CBXP90110B-VB-02B,03B

CBXP6070A-VB-02B

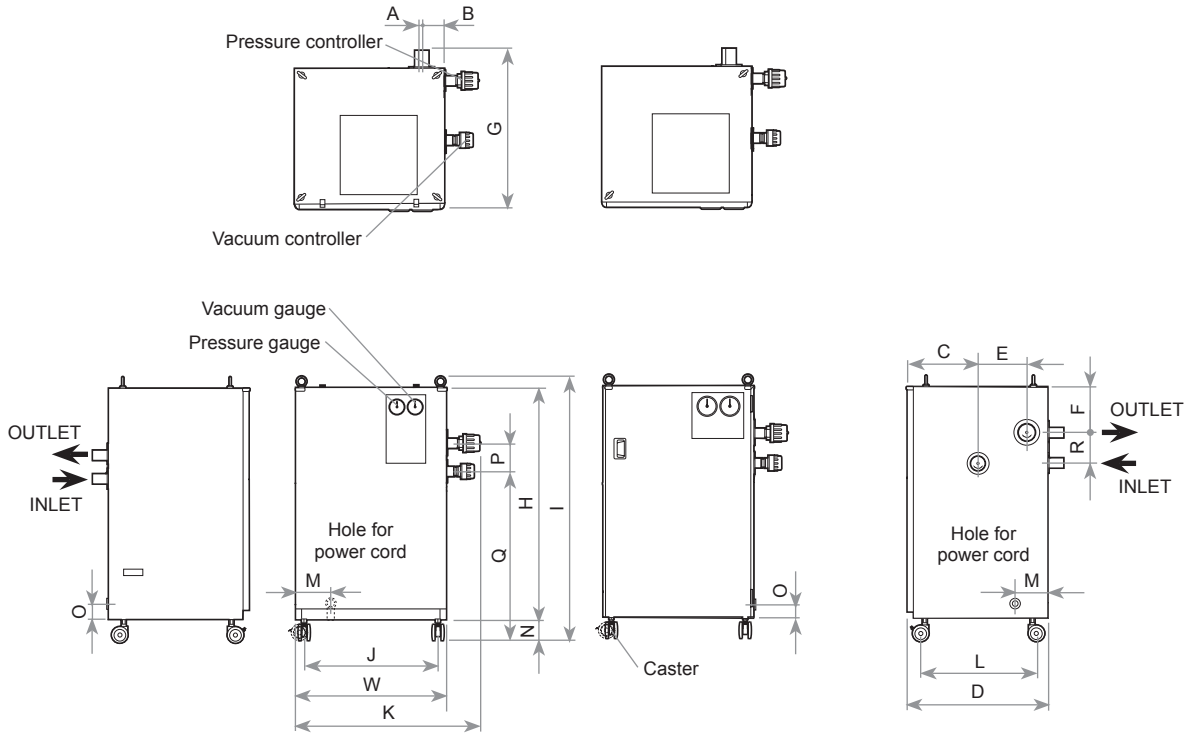

CBXP8080B-VV-02B,03B
 CBXP9090B-VV-02B,03B
 CBXP110110B-VV-02B,03B
 CBXP8080B-BB-02B,03B
 CBXP9090B-BB-02B,03B
 CBXP110110B-BB-02B,03B

CBXP6060A-VV-02B
 CBXP6060A-BB-02B

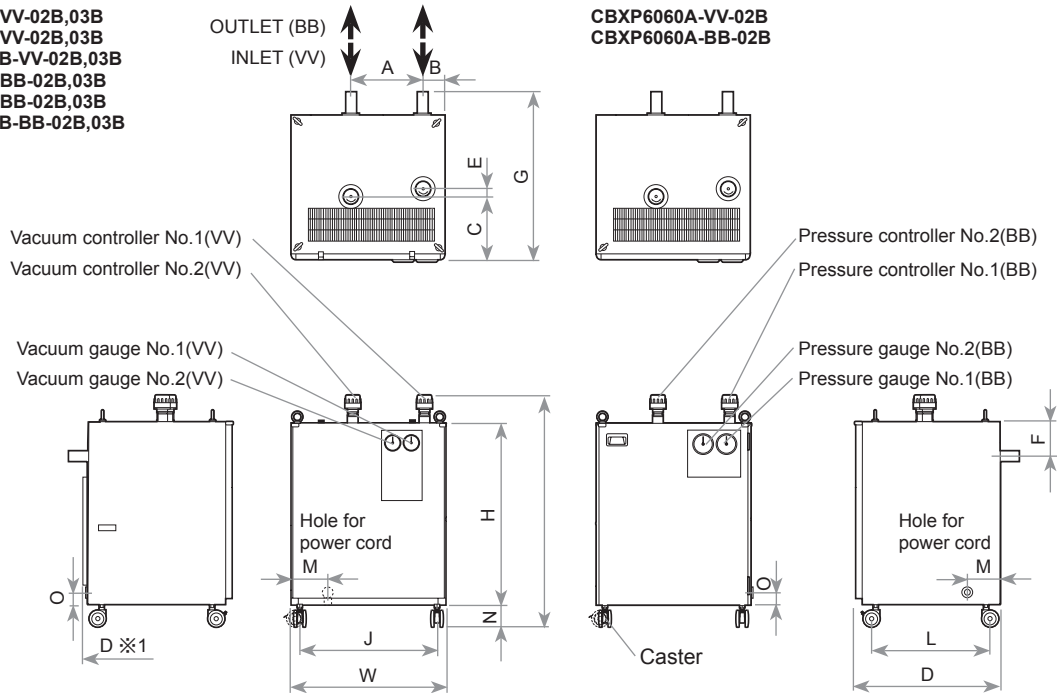

※ 1 CBXP110110B-VV-02B,03B/-BB-02B,03B models only



Direct Drive High Vacuum KHF Series

CE Certification Standard (04, 01B Models)

Ultimate Pressure:
8kPa [abs]

Continuous Operative Pressure:
Ultimate pressure to atmospheric pressure
(Note:KHF08-VH:Ultimate pressure to 48kPa [abs])

Flow Capacity:
150 ~ 400 L/min (60Hz)

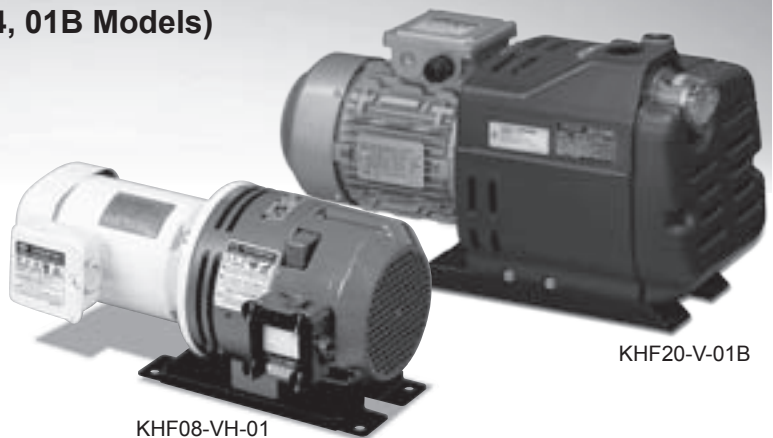

Features

- Meets CE certification standards. (04 Models)
- Continuous operation at ultimate pressure.
- Easier vane blade replacement (compared with KHA models.)
- High degree of vacuum, excellent substitute pump for ejectors and electronic component and small parts handling automated equipment.

Specifications

□ Single phase ■ 3 Phase model

Model	Designed pumping capacity		Ultimate pressure	Operable pressure range	Air inlet/outlet port diameter	Voltage			Standard motor current rating		Noise level		Motor	Mass		
						Voltage		A								
						Single phase	3 phase		Single phase (02)	3 phase (01,01B&04)		(dB)※3		kW	kg	
100/200V	200V	220V	100/200V	200V	220V	50Hz	60Hz	Single Phase	3 phase							
KHF08- □ - □																
VH-01	125	150	8	Ultimate pres. ~ 48	Rc 1/4	—	○	○	—	1.3/1.1	1.1	64	67	0.2	—	13.5
VH-02	125	150	8	Ultimate pres. ~ 48	Rc 1/4	○	—	—	3.8/3.4, 1.9/1.7	—	—	64	67	0.2	15.5	—
VH-04(CE)	125	150	8	Ultimate pres. ~ 48	Rc 1/4	—	○	○	—	1.3/1.1	1.1	64	67	0.2	—	13.5
KHF14- □ - □																
V-01	230	280	8	Ultimate pres. ~ 101.3	Rc 3/4	—	○	○	—	2.6/2.5	2.5	66	68	0.4	—	22.5
V-02	230	280	8	Ultimate pres. ~ 101.3	Rc 3/4	○	—	—	6.8/6.0, 3.4/3.0	—	—	66	68	0.4	24	—
V-04(CE)	230	280	8	Ultimate pres. ~ 101.3	Rc 3/4	—	○	○	—	2.6/2.5	2.5	66	68	0.4	—	22.5
KHF20- □ - □																
V-01B(CE)	340	400	8	Ultimate pres. ~ 101.3	Rc 3/4	—	○	○	—	3.99/3.47	3.49	67	69	0.75	—	32
V-02	340	400	8	Ultimate pres. ~ 101.3	Rc 3/4	○	—	—	11.0/10.4, 5.5/5.2	—	—	67	69	0.75	35	—

※1 Designed pumping capacity: Theoretical value calculated from cylinder volume. Refer to "Performance Data" for actual flow rate. ※2 Pump can be continuously operated at the maximum attainable vacuum. ※3 Operating noise level measured on a new pump with the standard built-in ORION motor. Operating noise levels are from a position of 1m in front of the unit and at a height of 1m. ※ Please consult your dealer regarding continuous operation at levels on the dotted lines in the performance data charts. ※ Maximum operational pressure variation pulse: 13.3kPa[abs]/s. ※ Allowable back pressure for exhaust ducting: 10kPa or lower. (This pressure should not be used for any other purpose.) ※ Operating environment (inlet air) conditions: air temp: 0 ~ 40°C, humidity: normal levels (65±20%). ※ Due to the high compression ratios found in high-vacuum pumps, condensation can easily form within the pump. Therefore the following measures should be taken in order to avoid trouble from rust due to condensation: **During a trial run (operation of 5 minutes or less, such as a momentary operation or short test run) if the operating pressure goes above 48kPa[abs], then a dry run of 10 to 15 minutes should be made at a pressure of 48kPa[abs] at the vacuum side of the pump.** ※ Allowable intermittent power supply voltage fluctuation range is ±10% of the specified voltage; allowable sustained supply voltage fluctuation range is ±5% of the specified voltage. ※ Please install an overload protection device (such as a thermal relay). ※ Single phase models require pre-order. ※ **For detailed specifications, please refer to the specifications sheet.**

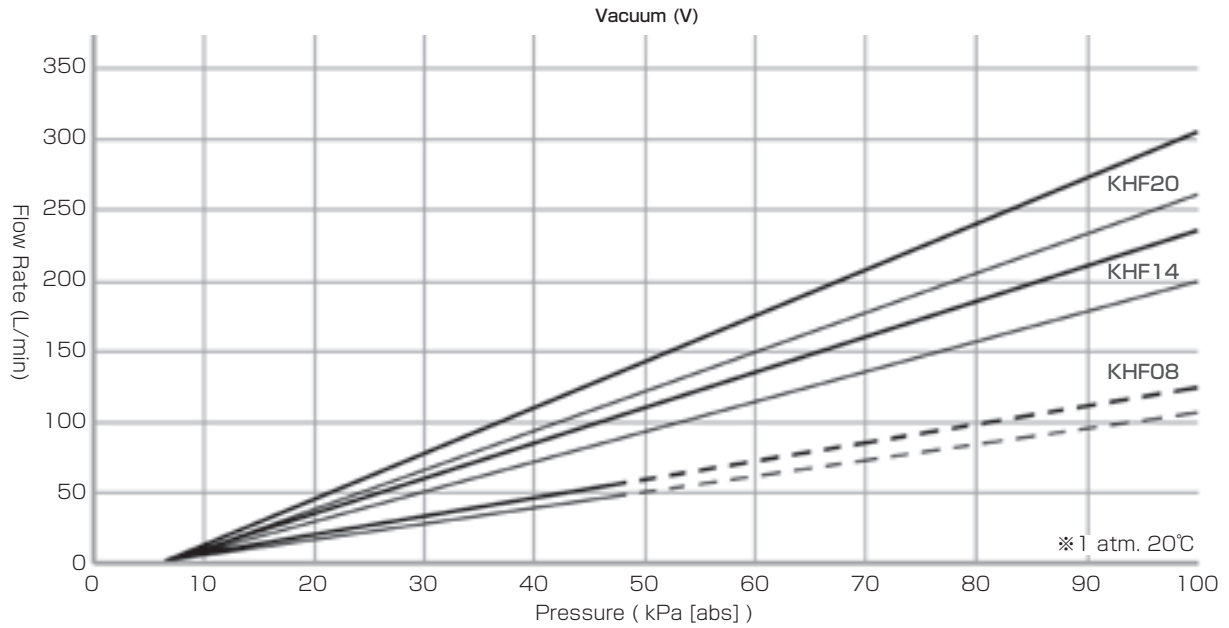

※ Please consult with your dealer in advance for continuous operation at 48kPa[abs] or higher (just on the performance-data dotted line).

Outside Dimensions (Units:mm)

KHF08-VH-01,04 ※

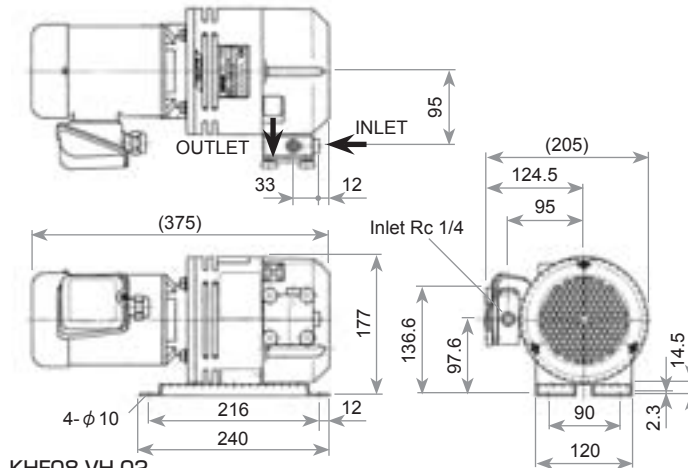

KHF14-V-01,04 ※
KHF20-V-04 ※

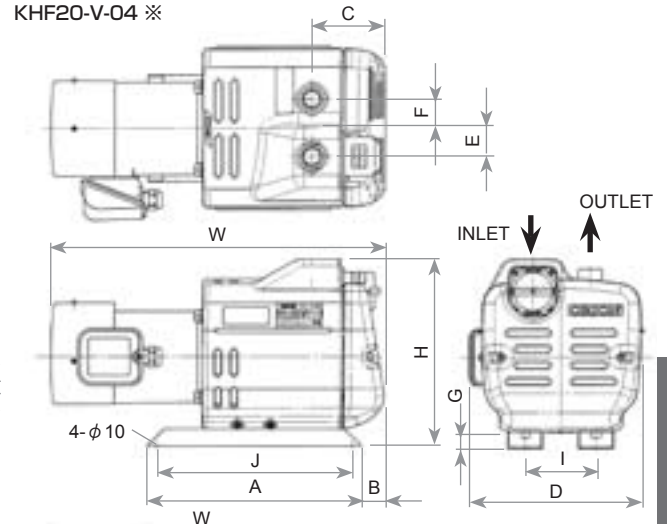

KHF08-VH-02

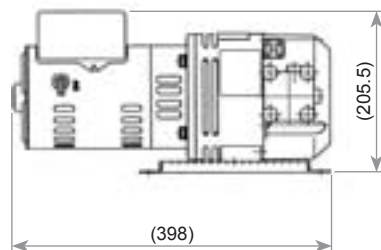

KHF20-V-02

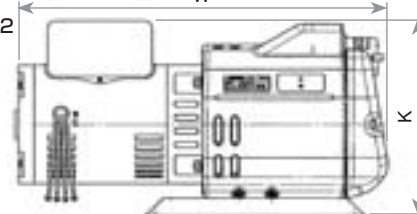

KHF14-V-02

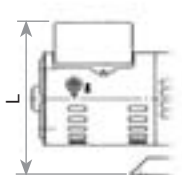

KHF20-V-01B

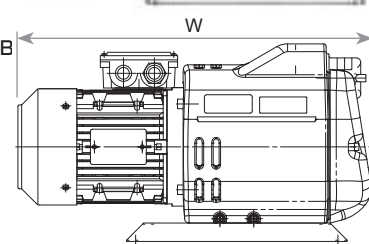

Direct Drive High Vacuum
KHF Series

Model	H	D	W	A	B	C	E	F	G	I	J	K	L
KHF14-V-01	(245)	(237)	(458)	300	(17)	(100)	42	35	25	80	275	—	—
KHF14-V-02	(245)	(202)	(455)	300	(17)	(100)	42	35	25	80	275	—	(218)
KHF14-V-04	(245)	(237)	(458)	300	(17)	(100)	42	35	25	80	275	—	—
KHF20-V-01B	(269)	(232)	(481)	300	(33)	(103)	40	41	25	100	275	—	—
KHF20-V-02	(269)	(232)	(513)	300	(33)	(103)	40	41	25	100	275	(274)	—

※ The indicated diagrams are drawn based on CE certified models.



High Vacuum KHA Series

Ultimate Pressure: 8kPa[abs].
Flow Capacity: 65 ~ 400 L/min (60Hz)



KHA400-301A-G1

Features

- Continuous operation at ultimate pressure (8kPa).
- High degree of vacuum, excellent substitute pump for electronic component and small parts handling automated equipment.

Specifications

Model	Designed pumping capacity		Ultimate pressure	Air inlet/ outlet port diameter	Voltage		Standard motor current rating		Noise level		Motor	Mass			
					3 phase		3 phase		(dB)※3						
	L/min ※1				kPa[abs] (max.) ※2	200V	220V	200V	220V	50Hz			60Hz	kW	kg
	50Hz	60Hz				50/60Hz	60Hz	50/60Hz	60Hz						
KHA □ - □ - □															
100-301-G1	55	65	8	Rc 1/4	○	○	0.69/0.6	0.62	60	61	0.1	11			
200-301A-G1	120	145	8	Rc 1/4	○	○	1.56/1.37	1.36	61	62	0.2	13			
400-301A-G1	220	260	8	Rc 3/8	○	○	2.29/2.08	1.99	63	66	0.4	21			
750-301B-G1	330	400	8	Rc 3/8	○	○	3.8/3.4	3.4	67	70	0.75	38			

※1 Designed pumping capacity: Theoretical value calculated from cylinder volume. Refer to "Performance Data" for actual flow rate. ※2 Pump can be continuously operated at the maximum attainable vacuum. ※3 Operating noise level measured on a new pump with the standard built-in ORION motor. Operating noise levels are from a position of 1m in front of the unit and at a height of 1m. ※ Working vacuum range: 48kPa[abs] to ultimate pressure. ※ Maximum operational pressure variation pulse: 13.3kPa[abs] /s. ※ Models with ductable exhaust available (KHA100A · 200A · 400A · 750A). When ducting off exhaust, the allowable back pressure from the piping is 25kPa. (This pressure should not be used for any purpose.) ※ Operating environment (inlet air) conditions: air temp: 0 ~ 40°C, humidity: normal levels (65±20%). ※ Due to the high compression ratios found in high-compression pumps, condensation can easily form within the pump. Therefore the following measures should be taken in order to avoid trouble from rust due to condensation: **During a trial run (operation of 5 minutes or less, such as a momentary operation or short test run) if the operating pressure goes above 48kPa[abs], then a dry run of 10 to 15 minutes should be made at a pressure of 48kPa[abs] at the vacuum side of the pump.** ※ Allowable intermittent power supply voltage fluctuation range is ±10% of the specified voltage; allowable sustained supply voltage fluctuation range is ±5% of the specified voltage. ※ Please install an overload protection device (such as a thermal relay). Setting guideline (may vary depending on the specific application): For Three-phase motors, use the current rating listed on the motor nameplate as a guide. ※ **For detailed specifications, please refer to the specifications sheet.**

Performance Data

— 50Hz — 60Hz

Vacuum (V)

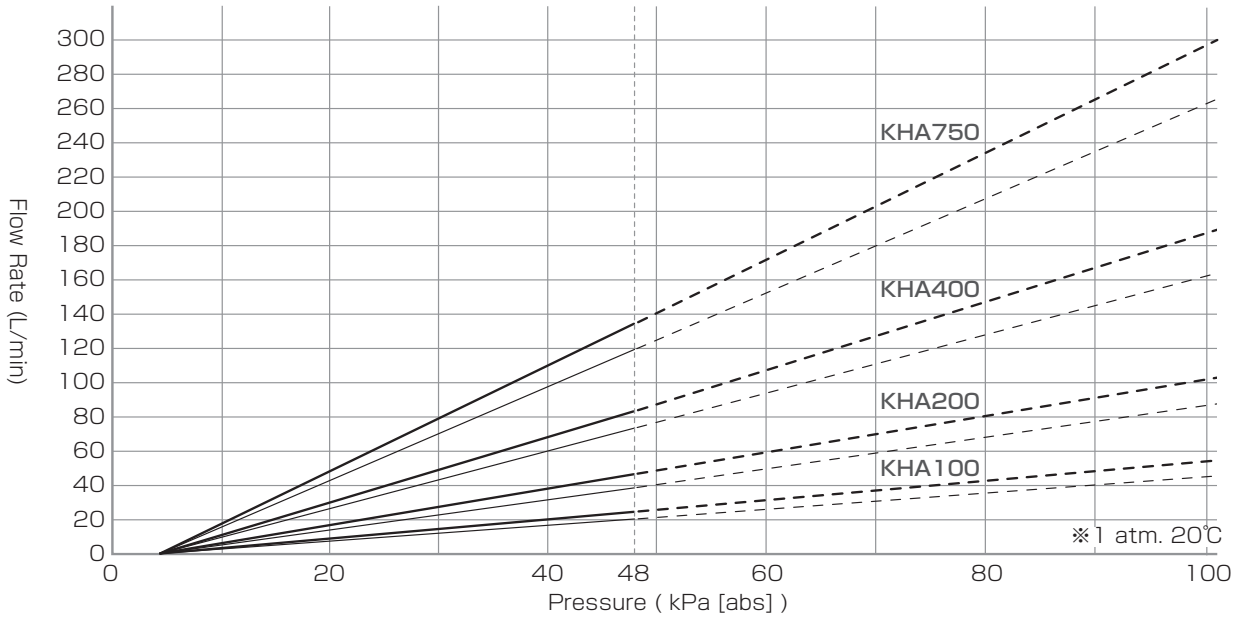

※ Please consult with your dealer in advance for continuous operation at 48kPa[abs] or higher (just on the performance-data dotted line) .

Outside Dimensions (Units:mm)

KHA200-301A

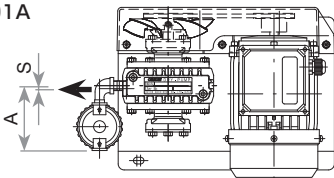

KHA400-301A

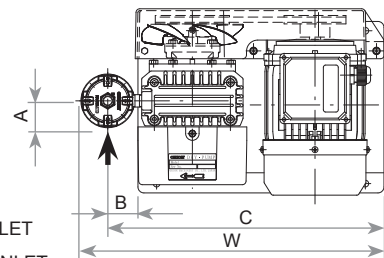

KHA200A-301A

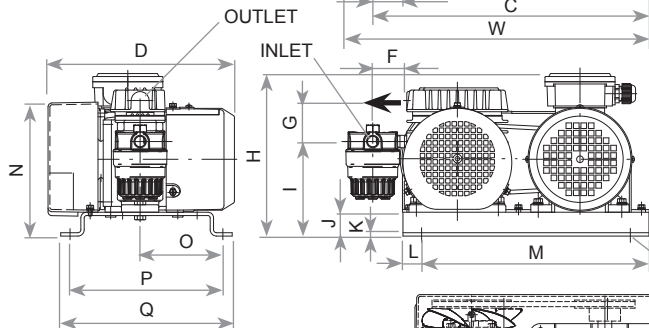
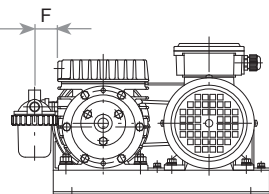

KHA100-301

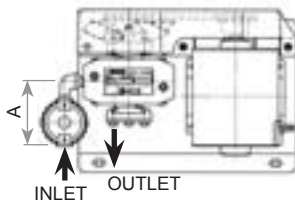

KHA750-301B

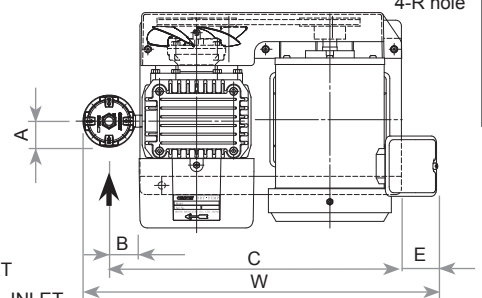

KHA100A-301

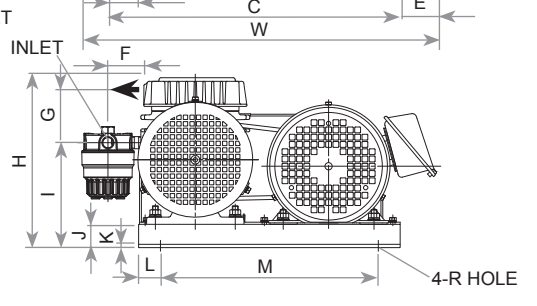
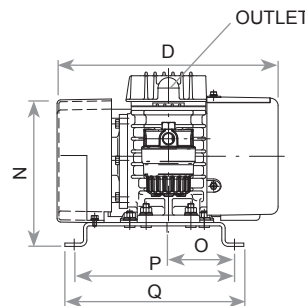
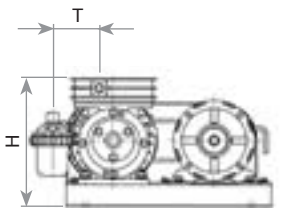

High Vacuum KHA Series

Model	H	D	W	A	B	C	E	F	G※	I	J	K	L	M	N	O	P	Q	R	S※	T※
KHA100-301-G1	(184)	(218)	(340)	(87)	(19)	309	—	—	57.5	112	32	3.2	25	240	164	109	180	205	5	—	66
KHA200-301A-G1	(202)	(228)	(346)	(87)	(25)	315	—	(31)	51.4	117	32	3.2	25	240	164	100.5	180	205	4	—	—
KHA400-301A-G1	(218)	(250)	(407)	33.5	(41)	370.5	—	(46)	55	127	32	4.5	25	280	180	111	205	230	φ9	—	—
KHA750-301B-G1	(234)	(296.5)	(481)	33.5	(43)	402.5	(42)	(50)	68	144.5	32	4.5	30	300	198	88.5	215	240	φ10	—	—

※ G,S,U specifications are for A type (exhaust ductable) models only.



High Vacuum KHH251

High Vacuum 1.3kPa [abs] Continuous & Dry

Ultimate Pressure: 1.3kPa[abs].
Flow Capacity: 179 L/min (60Hz)



KHH251-101

Features

- Continuous operation at ultimate pressure of 1.3 kPa or lower. Suitable for applications requiring high degree of vacuum.
- Compact design thanks to direct connect motor flange.
- Quiet operation, long life.

Specifications

□ Single phase

Model	Designed pumping capacity		Ultimate pressure (min.)	Air inlet outlet port diameter	Voltage	Standard motor current rating		Noise level		Motor	Mass
	L/min ※1					A	dB※3	kW	kg		
	50Hz	60Hz			Single phase					Single phase	50Hz
KHH251-101	149	179	1.3	Hose nipple (OD φ 14)	100V	6.1/5.5	68	69	0.25	19	

※1 Designed pumping capacity: Theoretical value calculated from cylinder volume. Refer to "Performance Data" for actual flow rate. ※2 Pump can be continuously operated at the maximum attainable vacuum. ※3 Operating noise level measured on a new pump with the standard built-in ORION motor. Operating noise levels are from a position of 1m in front of the unit and at a height of 1m. ※ Working vacuum range: 8kPa[abs] to ultimate pressure. Please consult your dealer regarding continuous operation at levels on the dotted lines in the performance data charts. Models with ductable exhaust available (KHH251A) are also available. When ducting off exhaust, the allowable back pressure from the piping is 10kPa. (This pressure should not be used for any purpose.) ※ Operating environment (inlet air) conditions: air temp: 0 ~ 40°C, humidity: normal levels (65±20%). ※ Due to the high compression ratios found in high-compression pumps, condensation can easily form within the pump. Therefore the following measures should be taken in order to avoid trouble from rust due to condensation: **During a trial run (operation of 5 minutes or less, such as a momentary operation or short test run) if the operating pressure goes above 8kPa[abs], then a dry run of 10 to 15 minutes should be made at a pressure of 8kPa[abs] at the vacuum side of the pump.** ※ Allowable intermittent power supply voltage fluctuation range is ±10% of the specified voltage; allowable sustained supply voltage fluctuation range is ±5% of the specified voltage. ※ Please install an overload protection device (such as a thermal relay). Setting guideline (may vary depending on the specific application): Use the current rating listed on the motor nameplate as a guide. ※ This is a precision made device. Please handle with care during shipping and installation. ※ For detailed specifications, please refer to the specifications sheet.

High Vacuum KHH251

Performance Data

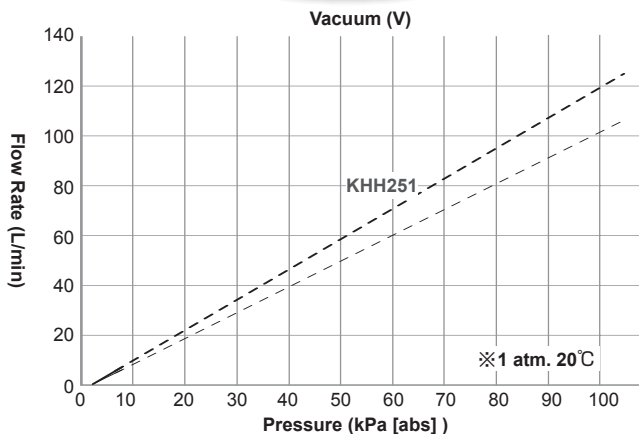

※ Please consult with your dealer in advance for continuous operation at 8kPa [abs] or higher (just on the performance- data boundary line).

Outside Dimensions (Units:mm)

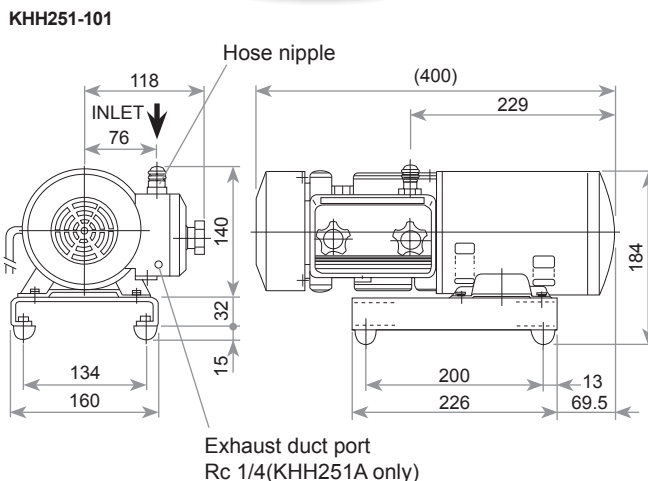



Silent Box KCS Series

Soundproofing Box for Dry Pumps

Dry pump soundproofing and functionality for a quieter and better work environment.
ORION Silent Box



Features

- 5 ~ 10dB reduction in pump noise.
- Removable front and back panels for easy pump access and maintenance.
- Electric cooling fan for internal temperature control.

Specifications

Applicable Pump	Vacuum, exhaust port diameter	Motor Voltage			Allowable ambient temperature ℃	Ventilation fan motor W	Mass kg	Accessories included
		Single-phase	3-phase					
			100/200V 50/60Hz	200V 50/60Hz				
KHA Series/ KCS21A-0 □ □ 1	Rp 3/4	○	○		0 ~ 35	11/15.5	21	Connection & fitting parts
KRF08A · KRF15A/ KCS31A-0 □ □ 3	Rp 3/4	○	○		0 ~ 35	11/15.5	22	Connection & fitting parts
KRF25A · KRF40A KHA750 · 750A/ KCS61A-0 □ □ 1 · 3	Rp 3/4	○	○		0 ~ 35	11/15.5	32	Connection & fitting parts
KRF70/ KCS70- □ -01,01A	R1	—	○		0 ~ 35	25	75	Connection & fitting parts
KRF110/ KCS110- □ -01	R1 1/4	—	○		0 ~ 35	25	90	Connection & fitting parts

- ※Dry pump sold separately. ※Silent Box is equipped with internal thermostat relay to be attached to user provided warning system/alarm.
- ※The KHA750 and 750A models fit in the KCS61A-0121 model Silent Box but require an additional connection & fitting parts set (not included.)
- ※Optional caster set available on request for KCS21A, 31A, 61A models.
- ※See specifications sheet for further details.

Handling Notes & Recommendations

Install in locations that are:

- level and solid.
- well ventilated, ambient temperature of 0 ~ 35℃, normal humidity (65±20%).
- out of direct sunlight, away from heat sources.
- conveniently central to existing air piping.
- away from water and oil spray, and relatively dust free.
- convenient for pump maintenance or overhaul.
- The KCS Series is equipped with a thermostat relay. Please wire the relay to an appropriate alarm system or device.



Silent Box KCS Series

Model Number Nomenclature

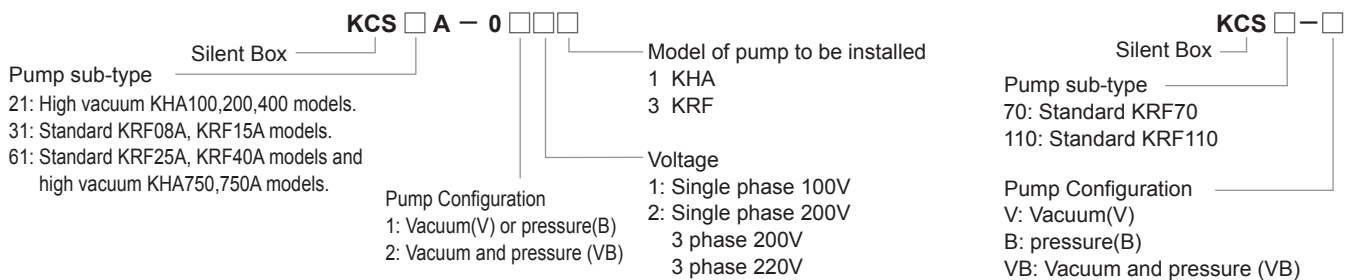

Model List

Silent Box Class	Type	Applicable Pump (sold separately)	Power Source
KCS21A Series for High Vacuum KHA Series Pumps	KCS21A-0111	KHA100-101 KHA200-101 KHA400-101	Single phase 100V 50/60Hz
	KCS21A-0211	KHA100A-101 KHA200A-101 KHA400A-101	Single phase 100V 50/60Hz
	KCS21A-0121	KHA400-101	Single phase 200V 50/60Hz
		KHA100-301 KHA200-301,301A ※1 KHA400-301,301A	3 phase 200V 50/60Hz 3 phase 220V 60Hz
KCS21A-0221	KHA400A-101	Single phase 200V 50/60Hz	
	KHA100A-301 KHA200A-301,301A ※1 KHA400A-301,301A	3 phase 200V 50/60Hz 3 phase 220V 60Hz	
KCS31A Series for Standard KRF08A · 15A Pumps	KCS31A-0113	KRF08A, 15A-V-02, B-02	Single phase 100V 50/60Hz
	KCS31A-0123	KRF08A, 15A-V-01, B-01 KRF15A-V-01A, B-01A	3 phase 200V 50/60Hz, 3 phase 220V 60Hz
		KRF08A, 15A-V-02, B-02	Single phase 200V 50/60Hz
	KCS31A-0213	KRF08A, 15A-VB-02	Single phase 100V 50/60Hz
	KCS31A-0223	KRF08A, 15A-VB-01 KRF15A-VB-01A	3 phase 200V 50/60Hz, 3 phase 220V 60Hz
KRF08A, 15A-VB-02		Single phase 200V 50/60Hz	
KCS61A Series for High vacuum KHA750 · 750A Pumps	KCS61A-0121	KHA750-301 KHA750A-301 KHA750-301B-G1 KHA750A-301B-G1	※ Requires optional installation kit. 3 phase 200V 50/60Hz 3 phase 220V 60Hz
		KCS61A-0113	KRF25A-V-02, B-02
KCS61A Series for Standard KRF25A · 40A Pumps	KCS61A-0123	KRF25A-V-02, B-02	Single phase 200V 50/60Hz
		KRF25A-V-01, B-01 KRF25A-V-01A, B-01A ※2 KRF25A-V-01B, B-01B ※2	3 phase 200V 50/60Hz 3 phase 220V 60Hz
		KRF40A-V-01, B-01 KRF40A-V-01A, B-01A ※2 KRF40A-V-01B, B-01B ※2	3 phase 200V 50/60Hz 3 phase 220V 60Hz
	KCS61A-0213	KRF25A-VB-02	Single phase 100V 50/60Hz
	KCS61A-0223	KRF25A-VB-02 KRF25A-VB-01, 01A, 01B ※2 KRF40A-VB-01, 01A, 01B ※2	Single phase 200V 50/60Hz 3 phase 200V 50/60Hz 3 phase 220V 60Hz
KCS70 Series for Standard KRF70 Pumps	KCS70-V-01	KRF70-V-01, 01B KRF70-VH-01, 01B	3 phase 200V 50/60Hz, 3 phase 220V 60Hz
	KCS70-V-01A	KRF70-V-01A ※3 KRF70-VH-01A ※3	3 phase 200V 50/60Hz, 3 phase 220V 60Hz
	KCS70-B-01	KRF70-B-01, 01B KRF70-BH-01, 01B	3 phase 200V 50/60Hz, 3 phase 220V 60Hz
		KRF70-B-01A ※3 KRF70-BH-01A ※3	3 phase 200V 50/60Hz, 3 phase 220V 60Hz
	KCS70-VB-01	KRF70-VB-01, 01B KRF70-VBH-01, 01B	3 phase 200V 50/60Hz, 3 phase 220V 60Hz
		KRF70-VB-01A ※3 KRF70-VBH-01A ※3	3 phase 200V 50/60Hz, 3 phase 220V 60Hz
KCS110 Series for Standard KRF110 Pumps	KCS110-V-01	KRF110-V-01, KRF110-V-01B	3 phase 200V 50/60Hz, 3 phase 220V 60Hz
	KCS110-B-01	KRF110-B-01, KRF110-B-01B	3 phase 200V 50/60Hz, 3 phase 220V 60Hz
	KCS110-VB-01	KRF110-VB-01, KRF110-VB-01B	3 phase 200V 50/60Hz, 3 phase 220V 60Hz

※1 Remove the cable gland (cable fitting) from the motor before attaching the cabling to the motor.

※2 Use a motor wiring cable set 04037333020 (sold separately) when mounting a 01B series pump in a KCS unit designed for a 01 series pump.

※3 Use a motor wiring cable set 04105749010 (sold separately) when mounting a 01A series pump in a KCS unit designed for a 01 series pump.

※ Please consult your dealer for different power supply voltages.

Outside Dimensions (Units:mm)

KCS21A
KCS31A
KCS61A

KCS70-V-01,01A
KCS110-V-01

※ Diagrams are for KCS70-V-01 models.

※ Diagrams are for KCS110-V-01 models.

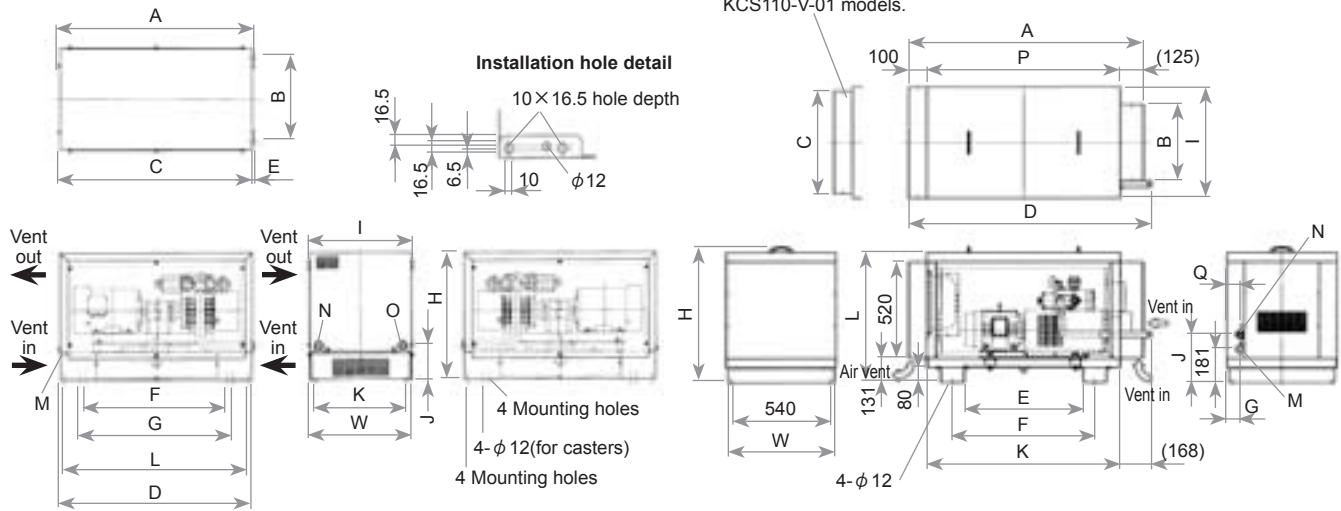

Model KCS	H	D	W	A	B	C	E	F	G	I	J	K	L
21A-0111	(415)	588	337	(602)	270	590	(5)	400	450	(351)	(113)	300	558
21A-0211													
21A-0121													
21A-0221													
31A-0111	(440)	588	337	(602)	270	590	(5)	400	450	(351)	(113)	300	558
31A-0121													
31A-0211													
31A-0221													
31A-0113													
31A-0123													
31A-0213													
31A-0223													
61A-0121	(500)	748	397	(762)	330	750	(5)	550	600	(411)	(137)	360	718
61A-0113													
61A-0123													
61A-0223													
70-V-01,01A													
110-V-01	(1480)	1435	600	(800)	930	92	(640)	286	1210				

Model KCS	M	N	O	P	Q
21A-0111	(φ19) Power cord hole	Plug (included)	Vacuum port INLET Rp 3/4	—	—
21A-0211		Exhaust OUTLET Rp 3/4			
21A-0121		Plug (included)			
21A-0221		Exhaust OUTLET Rp 3/4			
31A-0111	(φ19) Power cord hole	Vacuum port INLET Rp 3/4	Pressure (blower) port OUTLET Rp 3/4	—	—
31A-0121					
31A-0211					
31A-0221					
31A-0113					
31A-0123					
31A-0213					
31A-0223					
61A-0121	(φ19) Power cord hole	Vacuum port INLET Rp 3/4	Pressure (blower) port OUTLET Rp 3/4	—	—
61A-0113					
61A-0123					
61A-0223					
70-V-01,01A					
110-V-01	INLET R1 1/4	1210	82		

※Please consult your dealer for the exact dimensions of KCS70-B-01(VB-01) ,B-01A(VB-01A) and KCS110-B-01(VB-01) models.
 ※See specifications sheet for further details.

Silent Box KCS Series



Air Station AS135 Series (Built to order item)

Pump and Blower System Enclosure

Improve Your Shop Environment And Working Conditions

Installation Capacity:

Heat dissipation capacity of installed devices:
13.5kW or less (air-cooled and water-cooled types)



AS135A
Air-cooled model



AS135W
Water-cooled model

Features

- 1. Water-cooled and Air-cooled models available to best suite your working environment.**
Water-cooled models have nearly zero heat emission. Air-cooled models direct hot air away from your workspace.
- 2. Works with your existing configuration of pumps and blowers.**
- 3. 10 ~ 15dB sound reduction.**

Specifications

Model	Cooling type	Total installed pump capacity kW	Outside dimensions ※1			Air connections		Mass ※2 kg	Operable ambient temp. range °C
			mm			Inlet/Outlet port size max.	Number of connections Qty.		
			W	D	H				
AS135A	Air-cooled	Estimated total heat dissipation capacity for all installed pumps: 13.5	1500	1077	2099	Rc2	Max:10	380	5 ~ 35
AS135W	Water-cooled	Estimated total heat dissipation capacity for all installed pumps: 13.5	1500	1077	2411	Rc2	Max:10	420	5 ~ 35

Model	Cooling capacity	Cooling water connection	Cooling water conditions ※3			Ambient temp. °C	Ventilation air flow	
			Req. water flow	Temp. at inlet	Req. water pressure		m ³ /h	
			L/min	°C	MPa		50Hz	60Hz
AS135A	—	—	—	—	—	—	3360	3960
AS135W	13.5	Rc1	30 ~ 40	15	0.2	25	4800	5760

※1 Including warning lamp at top of unit. ※2 Does not include weight of installed pumps. ※3 Cooling capacity varies according to number and types of installed pumps, water flow, and water temperature. ※Custom models can also be built beyond the above specifications.



Water Separator RA41 • RA42

Water drop separation efficiency of 95%. Removing water from vacuum air expands the function of dry pumps.

Applications

- Food Packaging
- Automated Machinery
- Energy Saving Machinery



Photo:RA41

Specifications

Model	Air processing capacity	Operative vacuum	Air temp. at inlet	Ambient air temp.	Water absorption efficiency	Water collection capacity	Inlet/outlet port diameter	Mass	Applicable pump model
	L/min (max.)	kPa	°C	°C	%	cc		kg	
RA41	235 ~ 560	0 ~ 80	0 ~ 40	0 ~ 40	95	100	Rc3/4	1.0	KRF15A,25A,40A
RA42	235 ~ 1150	0 ~ 80	0 ~ 40	0 ~ 40	95	230	Rc1	1.7	KRF70

※ Stated air processing capacity at an intake degree of vacuum of 0kPa. ※ Stated vacuum pressures are gauge pressure values. ※ Since the life of the filter element depends on conditions of use, change the element when pressure loss is noticed during use. ※ Water drop collection efficiency refers to the rate of removal of over-saturated moisture (water drip, etc.) flowing into the water separator. Water drop separation efficiency (%)=Removed water drop quantity (g) ÷ total water drop quantity (g) which has flown into the channel × 100. ※ Water collection capacity is the maximum amount of water that can be collected at one time.

Precautions for Use

- (1) These models are for use with dry pump air intake purposes only. If they are used for purposes other than for dry pump air intake, the product may break and possibly cause injuries.
- (2) Use with simplified rust proofed dry pumps (R type). If the standard type or the high vacuum type (H type) are used, more rusting may occur inside the pump which can lead to pump trouble.
- (3) After ending daily operation, make a no-load run with the pump fully opened to the atmospheric air for about 10 minutes in order to prevent rusting inside the pump. Failure to do so may lead to rusting of the inside surfaces of the pump which can lead to pump damage.
- (4) When water accumulates up to the allowable water storage quantity, set the degree of vacuum inside the container to 0kPa (atmospheric pressure) and drain the water through the drain valve. If the water accumulation exceeds the allowable water storage quantity, the accumulated water will be blown into the pump during pump pulsations thus possibly damaging the pump.

Outside Dimensions (Units:mm)

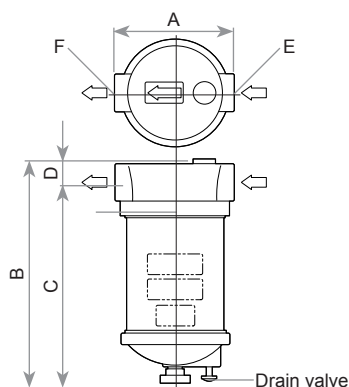

Model	A	B	C	D	E	F
RA41	120	217	(192)	25	INLET Rc 3/4	OUTLET Rc 3/4
RA42	140	264	(236)	28	INLET Rc 1	OUTLET Rc 1



Accessories

■ Clean Filter RA-S • RA-D Series

Helps prevent trouble due to oil mist and exhaust carbon.

RA-S (Oil mist collection filter)

RA-D (Exhaust carbon collection filter)

Features

- High collection efficiency
- Low pressure drop
- Low cost



Photo:RA-S

Photo:RA-D

Specifications

Model	Air processing capacity	Working vacuum	Working pressure	Inlet air temp.	Ambient air temp.	Collection efficiency	Inlet/outlet port dia.	Pressure drop meas. port dia.	Initial pressure drop	Mass	
											L/min
Vacuum filter	RA-53S	210	100	—	40	40	—	Rc3/4	Rc1/4	5.5	1.5
	RA-54S	440	100	—	40	40	—	Rc3/4	Rc1/4	5.5	2.5
	RA-55S	770	100	—	40	40	—	Rc3/4	Rc1/4	5.5	3.5
	RA-56S	1670	100	—	40	40	—	Rc1	Rc1/4	5.5	6.5
	RA-57S	1670	100	—	40	40	—	Rc11/4	Rc1/4	5.5	6.5
Exhaust filter	RA-53D	210	—	70	80	40	99% of particles 0.3 μ m and larger	Rc3/4	Rc1/4	5	2.0
	RA-54D	440	—	70	80	40		Rc3/4	Rc1/4	5	3.0
	RA-55D	770	—	70	80	40		Rc3/4	Rc1/4	5	4.5
	RA-56D	1670	—	70	80	40		Rc1	Rc1/4	5	9.0
	RA-57D	1670	—	70	80	40		Rc11/4	Rc1/4	5	9.0

Pump/Filter Compatibility

Model	Applicable pump	Use	Filter element
Vacuum filter	RA-53S	Protects pumps from oil mist entering pump.	EM-250S
	RA-54S		EM-500S
	RA-55S		EM-750S
	RA-56S		EM-1500S
	RA-57S		EM-1500S
Exhaust filter	RA-53D	Removes dust particles from pump exhaust air. (Removes 99% of particles 0.3 μ m and larger.)	EM-250Z
	RA-54D		EM-500Z
	RA-55D		EM-750Z
	RA-56D		EM-1500Z
	RA-57D		EM-1500Z

Outside Dimensions (Units:mm)

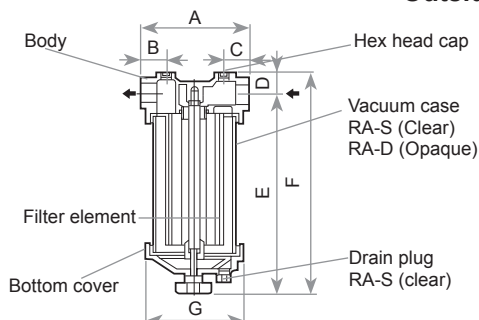

Model	A	B	C	D	E	F	G
RA-53S • D	130	30	30	24	246	270	φ 113
RA-54S • D	170	35	35	24	329	353	φ 154
RA-55S • D	170	35	35	24	559	583	φ 154
RA-56S • D	195	42	42	33	806	839	φ 181
RA-57S • D	195	42	42	33	806	839	φ 181

Note: The following accessories are for use only with the specified ORION pumps. Do not use on other non-specified equipment. (Vacuum controller, pressure controller, filter, oil separator, DA Series after-cooler, compound gauges.)

■ Type A Compound Gauge

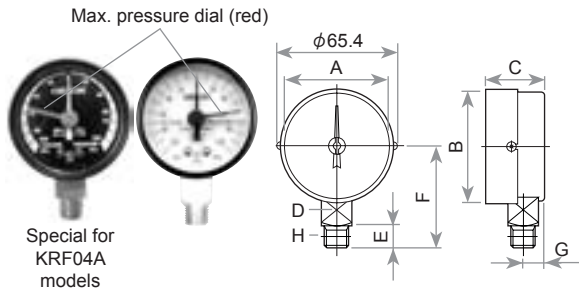

Specifications

Type	Range	Pressure reading	Units
Type A	Vacuum · Pressure	100	kPa

Outside Dimensions (Units:mm)

A	B	C	D	E	F	G	H
φ 58 (visible part)	φ 63	33	□ 17	12	56	11.5	R1/4 (PT1/4)

Specifications

Type	Range	Pressure reading	Units
Type D	Vacuum · Pressure	100	kPa

Outside Dimensions (Units:mm)

A	B	C	D	E	F	G	H
φ 58 (visible part)	φ 63	33	□ 17	12	20	—	R1/4 (PT1/4)

■ Type D Compound Gauge

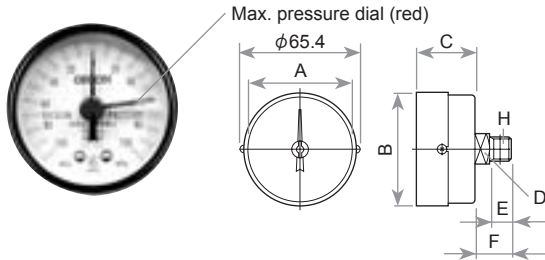

Specifications

Type	Range	Pressure reading	Units
Type D	Vacuum · Pressure	100	kPa

Outside Dimensions (Units:mm)

A	B	C	D	E	F	G	H
φ 58 (visible part)	φ 63	33	□ 17	12	20	—	R1/4 (PT1/4)

■ Type D (KRF use) Compound Gauge

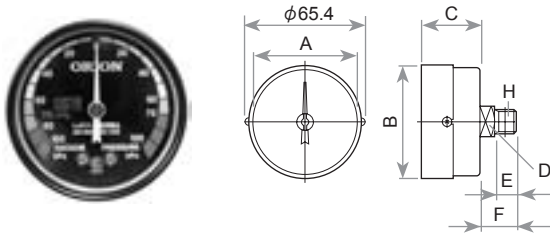

Specifications

Type	Range	Pressure reading	Units
Type D	Vacuum · Pressure	100	kPa

Outside Dimensions (Units:mm)

A	B	C	D	E	F	G	H
φ 58 (visible part)	φ 63	33	□ 17	12	20	—	R1/4 (PT1/4)

■ Type D (CBF use) Compound Gauge

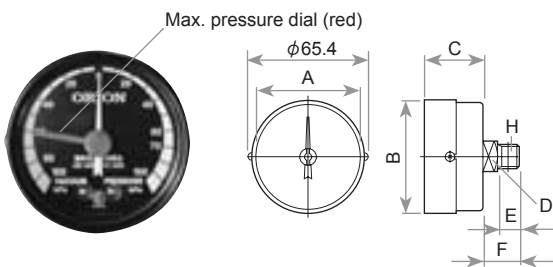

Outside Dimensions (Units:mm)

Model	VC10	VC32	VC63 · VC63B	VC81	VC100
A	φ 28	φ 35	φ 52	φ 62	φ 78
B	R1/8	R 3/8	R 3/4	R1	R1 1/4
C	66	54	78	83	107
D	70	60	87	94	120
E	4	6	9	11	13

※ VC63B is for KRF40 and CBF4040 pumps only.

■ Vacuum Controller

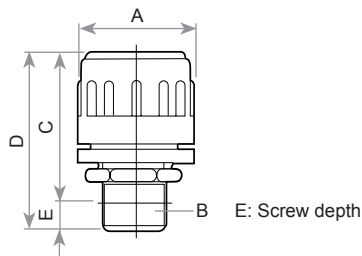

■ Pressure Controller

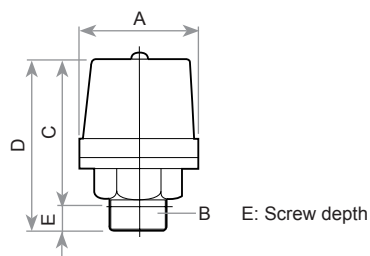

Outside Dimensions (Units:mm)

Model	PC32	PCA6	PCA8	PCA10
A	φ 35	φ 60	φ 70	φ 82
B	R3/8	R 3/4	R 1	R1 1/4
C	54	80	72	107
D	60	89	103	120
E	6	9	11	13



Accessories

Note: The following accessories are for use only with the specified ORION pumps. Do not use on other non-specified equipment. (Vacuum controller, pressure controller, filter, oil separator, compound gauges.)

Filter (For intake air)



RA10

RA11

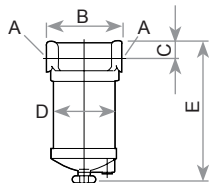

Outside Dimensions (Units:mm)

Model	A	B	C	D	E	Filter capacity
RA10	Rc 3/8	90	34	φ 80	182	10 μm
RA11	Rc 3/4	120	25	φ 89	220	30 μm
RA22	Rc 1	140	27.5	φ 114	265	30 μm

Oil Separator (For intake air) ※ Not for separating oil mist



RA31

RA32

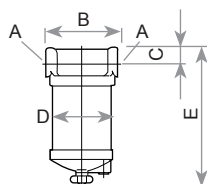

Outside Dimensions (Units:mm)

Model	A	B	C	D	E
RA31	Rc 3/4	120	25	φ 89	220
RA32	Rc1	140	27.5	φ 114	265

Vacuum Switch

※ Switch pressure set at factory. Please specify pipe tap size (G1/4 or G3/8) as well as desired ON and OFF pressure settings when ordering.

※ Ordered pressure settings can be set within one of 3 pressure ranges (A,B,C).



SVS-1

Outside Dimensions (Units:mm)

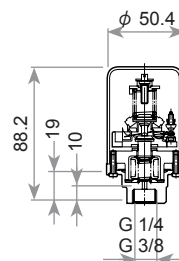

Specifications

Model	SVS-1
Switch voltage rating	AC250V 5A 125V 10A
Port tap size	G1/4、G3/8
Body material	Zinc die-cast, stainless steel
Pressure cell type	Stainless steel bellows, copper phosphate bellows
Cover	Polycarbonate

Range	Adjustable range	Differential pressure	Set point tolerance	Maximum working pressure	Standard settings
	min. ~ max. kPa	min. ~ max. kPa	kPa	MPa	lower ~ upper limit kPa
A	0 ~ 40	2.6 ~ 13.3	±1.3	0.49	20 ~ 26.7
B	40 ~ 66.7	6.7 ~ 40	±1.3	0.49	53.3 ~ 60
C	66.7 ~ 100	6.7 ~ 53.3	±1.3	0.49	80 ~ 86.7



SAFETY PRECAUTIONS

Danger/Warning precautions to consider before use

Before selecting and adopting a dry pump, be sure to read the catalog carefully to check and confirm all the contents such as features, specifications, operating conditions and precautions to make sure the selected type matches your application, purpose, and expected performance before determining your final selection and, also, use the dry pump properly within the ranges of the specifications.

DANGER

Indicates an imminently hazardous situation that, if the product is misused, may bring about death or serious injury to the operator.



Keep this equipment away from flammable fumes or explosive gases.

Ensure equipment is not exposed to nor is used in the vicinity of flammable fumes or explosive gases as doing so may lead to a fire or explosion.

WARNING

Indicates a potentially hazardous situation that, if the product is misused, may bring about death or serious injury to the operator.



Product Use Limitations

(1) If the unit is to be used as part of critical installations, safety devices and backup systems which can be switched to should be put into place to ensure that serious accidents or losses do not occur in the event that the unit should break down or malfunction.

(2) This product is designed and produced as a commodity for general manufacturing. Accordingly, the warranty does not apply to nor cover the following applications. However, in cases where the customer/user takes full responsibility and confirms the performance of the equipment in advance, and takes necessary safety precautions, please consult with ORION and we will consider if use of the unit in the desired application is appropriate.

- ① Atomic energy, aviation, aerospace, railway works, shipping, vehicles (cars and trucks), medical applications, transportation applications, and/or any applications where it might have a great effect on human life or property.
- ② Electricity, gas, or water supply systems, etc. where high levels of reliability and safety are demanded.



Do not operate with blocked exhaust piping. (Pressure (B) and/or Combination (VB) pumps)

Do not operate when the pressure controller is completely closed or when the exhaust piping is blocked. Doing so may result in increased pressure and temperatures within the piping and could result in burst piping or damage to the pump.



Do not wash filter element with organic solvents.

When cleaning the filter element, do not use organic solvents such as thinner, alcohol, benzene, gasoline, or kerosene. Doing so may result in an explosion or fire.



Do not remove equipment cover during operation.

Do not operate the product while the cover is removed. Doing so may result in serious injury to hands or other injuries as the fan, coupling, pulley and belt rotate at high speeds.



Do not put hands near rotating parts.

Doing so can result in serious injury to, or loss of a hand.



Ensure power cord is not damaged.

Do not damage, bend, pull, or bind the power cord. Do not place heavy objects on it nor let it get caught or pinched. Doing so may damage the cord which could result in electric shock or fire.



Keep this equipment away from water.

Do not pour water over this product nor use water to clean it. Furthermore, do not install the equipment where it may be exposed to water or other liquids. Doing so could result in electric shock or fire.



Be alert of possible electric shock.

Do not touch electrical parts such as the power cord with damp hands. Also do not operate switches with damp hands. Doing so might result in an electric shock.



Do not modify this equipment.

Modification of the equipment may result in injury, electric shock, or fire.



SAFETY PRECAUTIONS

Danger/Warning precautions to consider before use

Before selecting and adopting a dry pump, be sure to read the catalog carefully to check and confirm all the contents such as features, specifications, operating conditions and precautions to make sure the selected type matches your application, purpose, and expected performance before determining your final selection and, also, use the dry pump properly within the ranges of the specifications.

WARNING

Indicates a potentially hazardous situation that, if the product is misused, may bring about death or serious injury to the operator.



Be sure to properly ground the product.

Ensure the product is properly grounded from either the grounding screw inside the terminal box or at the lower part of the frame of the motor. Improper or lack of grounding may result in electric shock.



Installation of this product must be done by qualified personnel.

If improperly installed, the product may fall down or drop resulting in personal injury, electric shock, or fire.



Do not continue to operate this product if it is not working normally.

Stop operation if product does not function normally. Then remove the power cord or shut off the main power supply and consult with your dealer or a qualified repair company. Continued operation of the product when not operating properly can result in electric shock or fire.



Shut off the main power supply before cleaning, maintenance and inspection.

Shut off the main power supply before cleaning, maintenance and inspection, and clearly post a sign on the power supply switch to indicate it is under maintenance. Failure to do so may result in electric shock or personal injury. Consult with a specialized company for maintenance and inspection.



Inspect the power plug periodically.

If the product is operated with a power plug, periodically inspect the power plug and confirm it is not covered with dust. The power plug must be fully inserted to the root of pins. If the power plug is covered with dust or not fully inserted, it may cause electric shock or fire.



Be sure to install protective devices.

Consult with a specialized company to install an earth leakage breaker. Failure to do so may cause electric shock or fire. Also, install an overload protection device (thermal relay). Operation without such devices may cause malfunction due to overload or result in fire.



Always have 2 or more people when installing/moving equipment over 25kg.

When installing or moving equipment over 25kg, always lift and move using at least 2 people. And when lifting/moving, do not hold onto the motor control box, filter case, or controller. Dropping equipment may result in injury, damage to the equipment or improper function.



Always use a proper restraining tie-down belt to lift/move equipment over 50kg.

When moving equipment over 50kg, always use a tie-down belt to prevent dropping equipment. Not properly securing equipment when moving can lead to injury.



Use eye bolts properly.

When using eye bolts, hang the product from 2 points and ensure the cable angle at each point is at least 60 degrees to the base. Failure to handle properly may result in the product overturning or falling down.



Do not use the product outside.

The product is intended for indoor operation only. If the product is used outside and is exposed to wind or rain, the motor may suffer damage to the insulation which may result in electric shock or fire.



Make sure caster stoppers are locked.

After installation is complete, lock the stoppers on the front casters. Not doing so may lead to the product shifting or falling over which may result in personal injury or damage to the product.

CAUTION

Indicates a critical situation that, if the product is misused, may bring about injury to the operator or damage to the product.



Do not operate the product outside the voltage range specified on the motor.

Operation with any voltage other than the rated voltage specified for the motor may result in failure or accident.



Do not sit on, lean on, or place objects on the product.

Do not place heavy objects or objects containing water on the product. Do not sit or climb on the product. Doing so can result in injuries due to falls. If water spills on the product, rust or damage to insulation may result which could lead to ground leakage or electric shock.



Do not use the product beyond its specified pressure rating.

Using the product beyond its specified pressure rating may shorten the life and/or cause damage or failure of the product.



Burn Warning

Do not touch areas around the pump, the surface of the after cooler, the exhaust port, or the piping surface on the exhaust side. These surfaces may be hot and cause burns if touched.



Inspect the earth leakage breaker periodically.

Periodically check the earth leakage breaker to ensure it is working correctly. Failure of this device may lead to electric shock or a short circuit.



Install check valve.

Be sure to install a check valve in a horizontal position within 50cm of the suction (or exhaust port) of the pump in order to avoid reverse-rotation by residual pressure when stopping the pump. Failure to do so may result in injury or malfunction of pump. (Not necessary for KM41A, KYP, KHA, KHH, and KHF.)



Shut off the main power supply when not in use for extended periods.

When not used for extended periods, shut off main power supply. Failure to do so may result in electric shock, due to degradation of insulation, or fire due to electrical leakage.



To unplug, do not pull on cable – pull the plug itself.

When used with a power plug, remove the plug by grasping the plug and pulling it out. Removing the plug by pulling on the cord may result in partial separation of the core wire which can lead to heat and deterioration.



Ensure wiring does not come into contact with motor frame.

Install wiring such that wires do not come into contact with the motor frame otherwise heat from the motor may melt wire insulation or pose a fire risk.



Wear protective gear and clothing when performing cleaning and maintenance.

In order to prevent burns, wear gloves when maintaining or cleaning. Not wearing protective gear may result in burns or other injury due to contact with hot motor surfaces.



Wear protective gear and clothing when moving equipment.

When moving equipment, wear non-slip gloves and safety-shoes. Not wearing protective clothing while moving equipment may result in injury.



Continuous operation is recommended.

If start/stop frequencies are high (cycles of 5 minutes or less) the lifetime of the equipment may be significantly reduced or lead to deterioration or malfunction.



Do not wrap gauges or controllers with sealing tape.

When installing gauges or controllers, do not apply sealing tape on a threaded part. Doing so may dent, or warp the thread part and may also lead to improper operation.



ESCA

ESCA stands for "Energy Saving Clean Air"
ESCA is ORION's endeavor toward an energy saving environment.

Energy Saving Proposals

Using an ejector?

What if you could recover wasted compressed air and the wasted electric bill that goes with it?

Recover 60% of your electric costs by using a dry pump.

Energy Savings of 60%

Use of Dry Pumps
(Efficient vacuum supply)

Use of Air Ejectors
Ejectors waste energy by using compressed air to generate vacuum.

Exhaust

Nozzel

Large volume of compressed air

Weak source of negative-pressure

ESCA

Energy Saving Proposals

To users of Dry Pumps...

Are you wasting energy using your Dry Pump?

By not properly replacing filter elements as recommended...

Clogged filters lead to...

Reduced pump power... (less vacuum/pressure) → **over use of pressure regulator**

Increasing pressure or vacuum using pressure regulator

Wasted Electricity

↑ 10% waste

Current (A)

Pressure (kPa)

KRF40A

Reduced vane and bearing life

↓ 30% shorter part life

Part life (hr)

Vacuum (kPa)

KRF40A

Oil free vacuum pumps and blowers (Vaneless Pump)

KCP/KCE/KCM series

Recipient of the "Small and Medium Enterprise Excellent New Technology and New Product Prize for Excellence"
Winner: Prize of Excellence

The Resona Foundation For Small And Medium Enterprise Promotion · Nikkan Kogyo Shimbun Ltd.

KCE190A
[Inverter Model]

KCM620
[Module Multi Model]

KCE380A [Inverter Model]

KCP250 [Basic Model]

KCP150D [Basic Model]

Inverter Model / Module Multi Model

KCE/KCM Series Built-In  **eco speed control**

※1. eco speed control :
Energy saving mechanism that works by automatically adapting motor speed to changes in air consumption.

Ultra ECO Product : Energy Savings of 50% or Better (compared with previous models)

 "eco2" means Economy (energy savings) and Ecology (environmental protection) and reduced CO2 emissions.

Products by ORION

Dairy Equipment

Products

- Milking equipment
- Refrigerating equipment
- Feeding equipment
- Animal waste treatment equipment



Photo:
Milking Unit Automated
Transportation Equipment
Carry Robo UCA30A

Vacuum Pumps and Related Equipment

Products

- Dry Pump
(Oil-less rotary vane vacuum pump)
- Silent Box
(Dry pump soundproofing enclosure)
- Clean Filter



Photo : Dry Pump
KRFSeries

Heating Equipment

Products

- Jet Heater BRITE
(Infrared heater)
- Jet Heater HP
(Portable warm air heater)
- Jet Heater HS
(Convection warm air heater)



Photo : Jet Heater
BRITE
HRR480B-S

Refrigerating Equipment

Products

- Inverter Chiller
- Unit Cooler
(Fluid circulation refrigeration unit)
- Dehumidifier
- Food Processing and Preserving Equipment
- Others



Photo :
DC Inverter Chiller
RKE3750B-V

Compressed Air Equipment

Products

- Air Dryer
(Refrigerated compressed air dryer)
- Heatless Air Dryer
(Adsorption type compressed air dryer)
- Air Filter
(Compressed air purification equipment)
- Others



Photo :
DC Inverter Air Dryer
RAXE1100B-SE

Precision Air Processor

Products

- Precision Air Processor
- Precision Water Chiller
(Precision control of water temperature)
- In-Line Type Temperature Inspection Equipment
- Thermal Fresh
(Precision control of temperature and humidity)
- Others



Photo : Precision Air Processor
PAP10A1-K



Safety Precautions

Please read the Operator's Manual thoroughly and operate equipment accordingly.
For specialists in installation and wiring of ORION equipment, please consult your ORION dealer.
Choose the ORION product that best suits your needs. Please do not use any equipment in a manner for which it was not intended. Doing so may lead to equipment damage or failure.

Continually developing a complete and trustworthy nation-wide network of expedient sales and service everywhere, anytime.



ORION Machinery Co., Ltd is an ISO Certified, Quality Management and Environmental Management company.



ISO 9001 (Main Factory)



0105



認證番号00008-1

What is the ISO certification system?
ISO (International Organization for Standardization) is an established body that stipulates and certifies ISO9001 and ISO14001 directives. ISO9001 stipulates a system of Quality Management that ensures customer satisfaction and trust in a company's products and services it provides. ISO14001 stipulates a system of Environmental Management whereby production and business activities are carried out in an environmentally conscious manner.

For Orders and Inquiries:

ORION MACHINERY CO., LTD.

International Group 246, Kotaka, Suzaka-shi, Nagano-ken, 382-8502 Japan
TEL +81-(0)26-246-5664 FAX +81-(0)26-246-6753
Email: kokusai@orionkikai.co.jp

Head Office & Factory 246, Kotaka, Suzaka-shi, Nagano-ken, 382-8502 Japan
TEL +81-(0)26-245-1230 FAX +81-(0)26-245-5424
URL: <http://www.orionkikai.co.jp>

This catalogue contains product specifications as of March, 2015.

- Actual product colors may vary slightly from catalogue.
- The structure or specifications of products contained in this catalogue are subject to change without prior notice.