

CY150 Specification Sheet

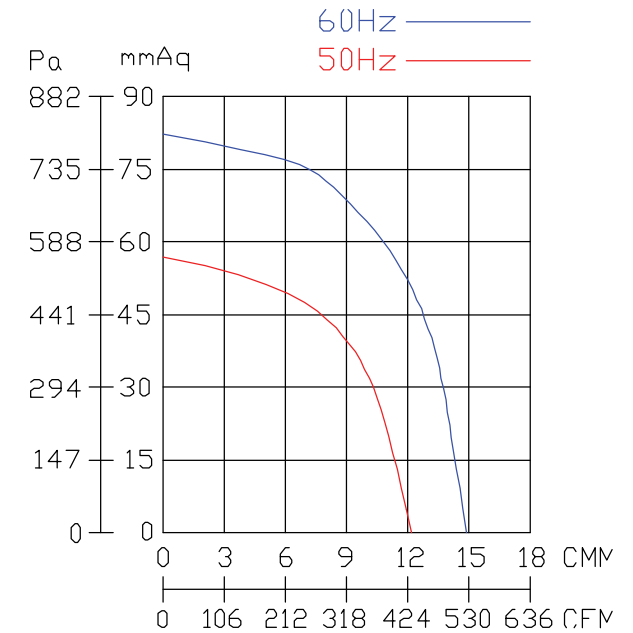

6"

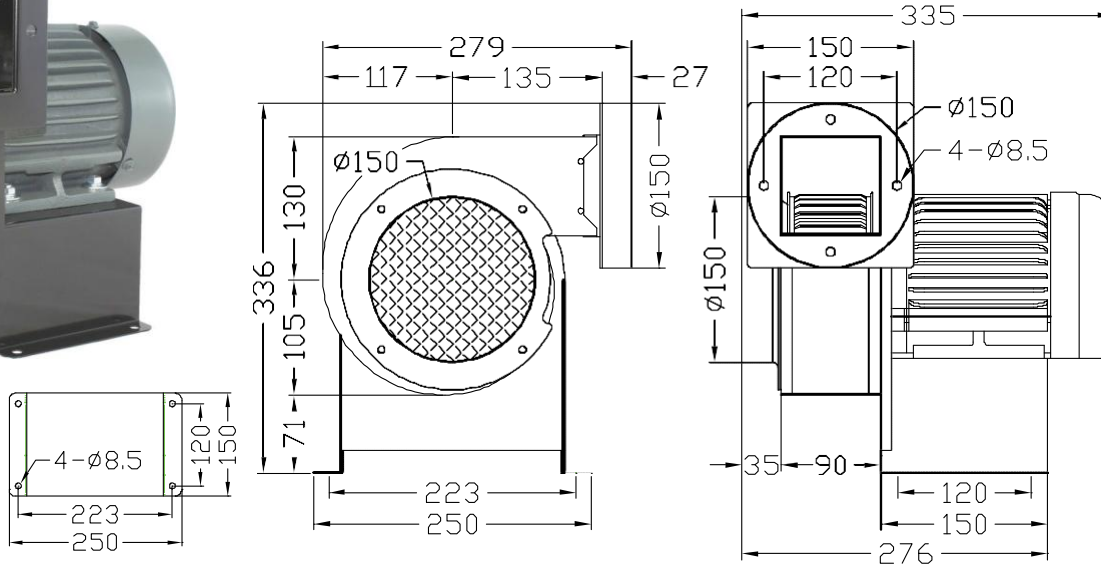

Model	Rated Voltage	Frequency	Phase	Pole	Current	Power	Speed	Max. Air Flow			Max. Pressure			Weight
	V							Hz	\emptyset	P	A	Watt/HP	R.P.M.	
CY150	240	50	1	2	5.5 / 2.8	1/2 HP	2930	12.5	750	441	58	2.28	569	16
		60			6.4 / 3.2		3460	14.8	888	522	84	3.31	824	
	415	50	3		1.8 / 1.0		2930	12.5	750	441	58	2.28	569	15
		60			2.0 / 1.1		3460	14.8	888	522	84	3.31	824	



CAM YORK INDUSTRIAL CO.,LTD.
 NO.613 Jifeng Rd., Wufeng Dist., Taichung City 413, Taiwan.

www.sunwins.com.my

E-mail: sales@sunwins.com.my