

# EV series 3-lobe roots compressors

## BRIEF INTRODUCTION:

EV series 3-lobe roots compressors are researched and developed on a basis of RSS series. The biggest feature of this compressor is high rotation speed (the maximum can be 4000RPM), high capacity. With the breakthrough of technology and the modification of practical application, EV series compressors have higher efficiency, higher pressure, lower weight and other features. The inlet sizes are from 2.5" to 12". The pressure of single compressor can be 1 Kgf/cm<sup>2</sup>



## FEATURES:

- **High Efficiency**

Great linear structure, reduce sectional area of rotors to improve capacity of compressors.

- **Low Vibration**

High grade of balance accuracy (G2.5) can control the vibration of X,Y, Z coordinate.

- **Low Loss of Pressure**

180 degrees vertical structure between inlet and outlet, reduce its pressure loss of compressors.

- **High Vacuum**

The vacuum of single EV compressor can be -500mmHg, and the two-stage EV compressor can be -650mmHg.

## OPERATING PRINCIPLE:

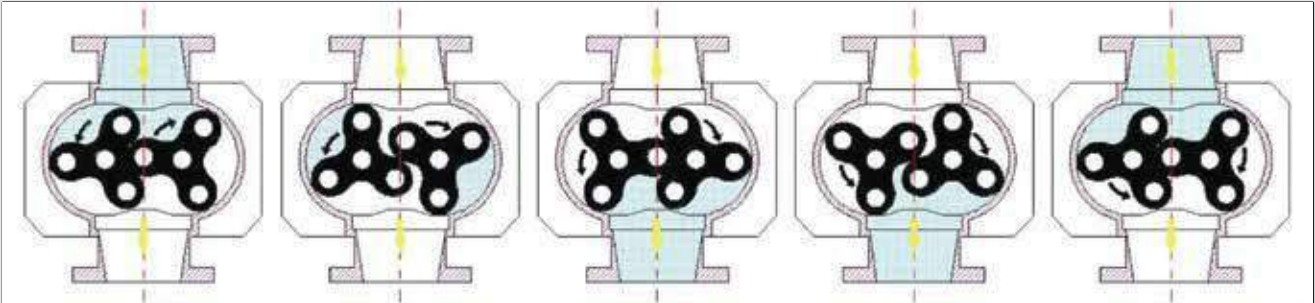

- **Compressor Working Principle**

Roots compressor is a cubage compressor, discharge airflow scale to the compressor's speed. Every rotation, there is two lobes to finish three times absorbing and discharging air, compared with two lobes compressor, the air is more smooth, smaller load change, higher strength, lower noise and vibration.

Two parallel shafts have three lobes each, all the lobes keep small clearance with each and housing inside. Every lobes rotation, a certain air will be absorbed at inlet and transferred from the housing inside surface to compressor's discharge port.

Two shafts will be turned by the timing gears, no any touching between lobes, so it can be turned at high speed without any lubrication inside. It has the following characteristics: simply configuration, running smoothly, and good performance stabilization. It has been applied for many fields.

## CONVERSION TABLE:

PRESSURE	atm	kPa	bar	lb/in <sup>2</sup>	kgf/cm <sup>2</sup>	in Hg	ftAq	mmHg(Torr)	mmAq
1 atm	1	101.325	1.0325	14.696	1.0333	29.921	33.914	760	10333
1 kpt	0.0099	1	0.01	0.145	0.0102	0.295	0.335	7.5	102
1 bar	0.9869	100	1	14.504	1.0198	29.53	33.47	750	10198
1 lb/in <sup>2</sup>	0.068	6.894	0.0689	1	0.0703	2.036	2.208	51.71	703
1 kgf/cm <sup>2</sup>	0.968	98.062	0.981	14.228	1	28.96	32.82	735.53	10000
1 in Hg	0.0334	3.3863	0.0339	0.491	0.0345	1	1.133	25.4	345.3
1 ftAq	0.0295	2.99	0.0299	0.434	0.0305	0.882	1	22.42	304.8
1 mmHg(Torr)	0.013	0.1338	0.00138	0.019	0.0014	0.04	0.045	1	13.6
1 mmAq	0.000097	0.0098	0.000098	0.0014	0.0001	0.003	0.0033	0.074	1

CAPACITY	m <sup>3</sup> /min	l/min	cm <sup>3</sup> /s	in <sup>3</sup> /s	ft <sup>3</sup> /min(cfm)
1 m <sup>3</sup> /min	1	1000	16667	1016	35.288
1 l/min	0.001	1	16.67	1.02	0.0353
1 cm <sup>3</sup> /s	0.00006	0.06	1	0.061	0.002
1 in <sup>3</sup> /s	0.00098	0.983	16.39	1	0.035
1 ft <sup>3</sup> /min(cfm)	0.028	28.32	471.95	28.8	1

### Pressure Conversion Formula

1 kPa= 1000 Pa= 1000N/m

1 mbar= 10.198 mmAq

1 mmHg(torr)= 133.8 Pa

## EV PARTS LIST

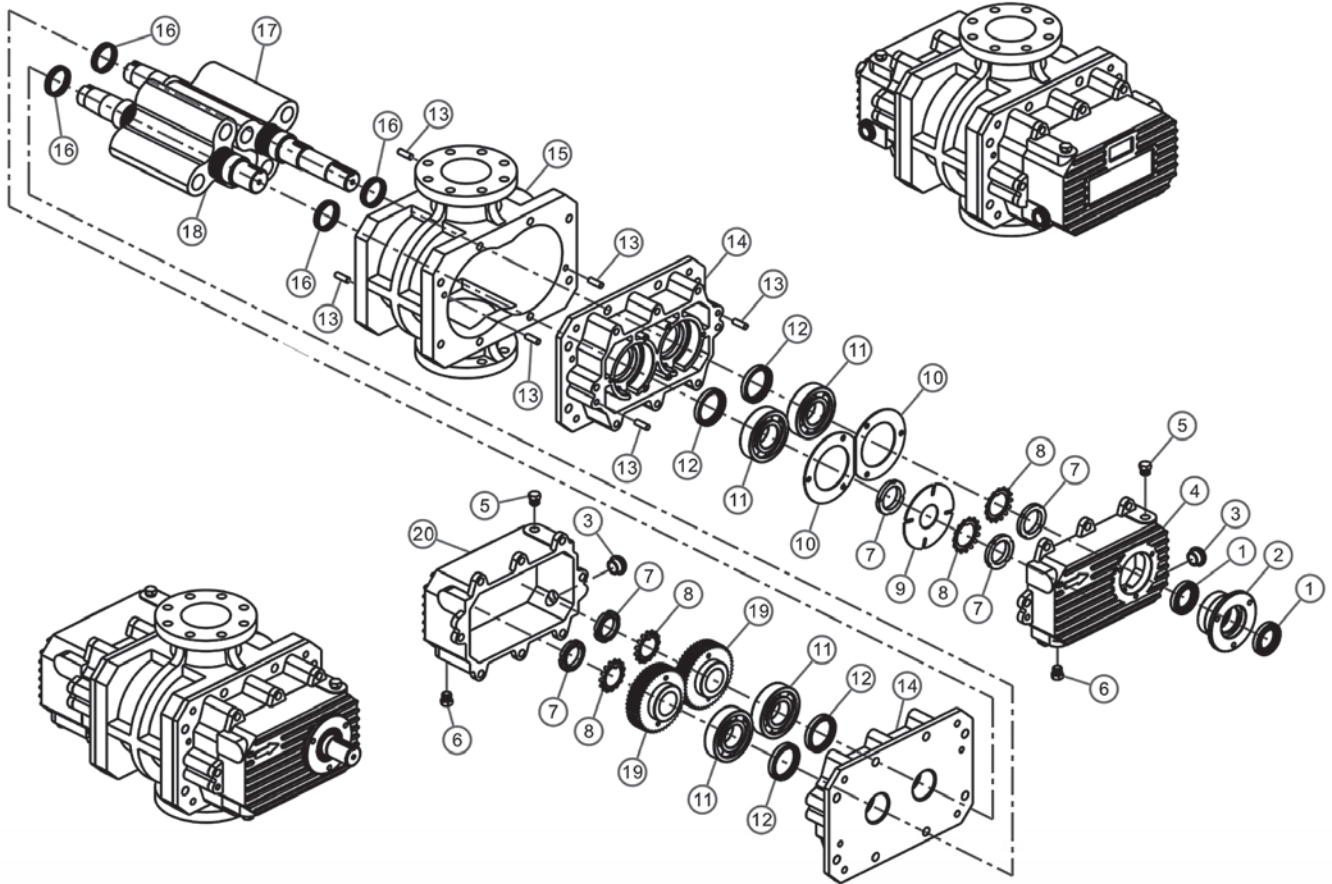

Item	Name	Material	QTY	Item	Name	Material	QTY
01	TC Oil seal	NBR	2	11	Bearing	SUJ2	4
02	Seal seat	FC250	1	12	TC Oil seal	NBR	4
03	Oil gauge	AL+glass	2	13		S45C	6
04	Oil reservoir	FC250	1	14	Bearing case	FC250	2
05	Lubricant plug	S45C	2	15	Casing	FC250	1
06	Purge plug	S45C	2	16	Piston ring	FC250	8
07	Locking nut	S45C	5	17	Drive lobe	FCD500	1
08	Lock washer	S45C	4	18	Driven lobe	FCD500	1
09	Oil thrower	SS400	1	19	Timing gear	SNCM220	2
10	Bearing fixtures	SS400	2	20	Gear reservoir	FC250	1

## EV MAIN-BODY DIMENSION

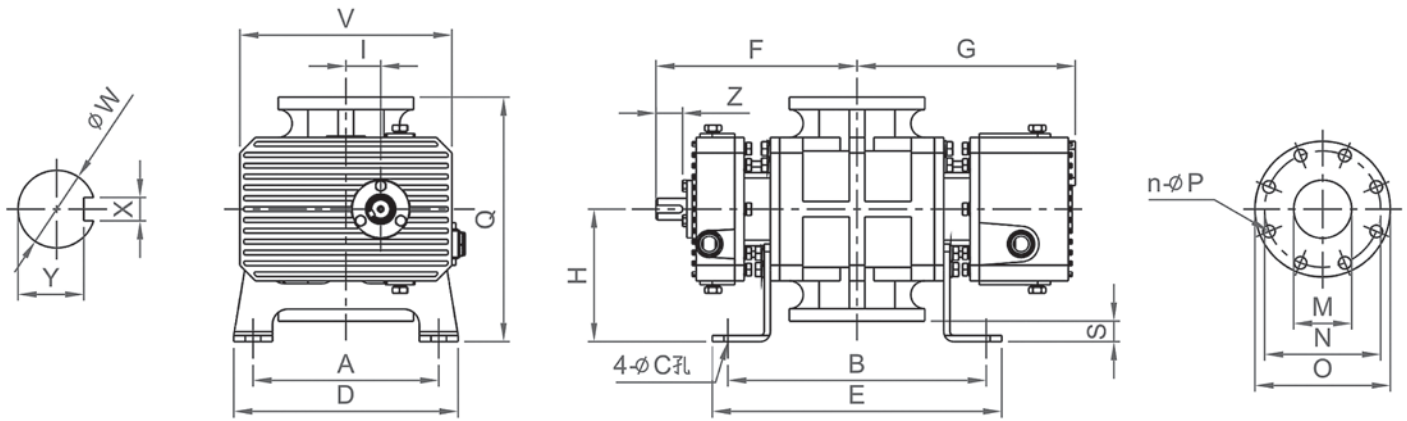

Model	A	B	φC	D	E	F	G	H	I	Q	S	V	φW	X	Y	Z	M	N	O	n-φP
EV-65	240	254	14	290	294	220	242	171	45	315.5	26.5	274	28	8	24	34	75	145	185	4-M16
EV-80	240	334	14	290	374	260	282	171	45	315.5	26.5	274	28	8	24	34	75	160	200	8-M16
EV-100	320	314	14	380	374	320	289	206	60	397	15	370	38	10	33	50	116	180	220	8-M16
EV-125	320	364	14	380	424	345	314	206	60	397	15	370	38	10	33	50	142	210	250	8-M20
EV-150A	350	406	19	430	446	400	380	248.5	80	481	16	474	48	14	42.5	86	167	240	285	8-M20
EV-150	350	526	19	430	566	460	440	248.5	80	481	16	474	48	14	42.5	86	167	240	285	8-M20
EV-200	475	530	19	540	586	476	440	290	100	495	85	590	55	16	49	90	200	295	340	8-M20
EV-250	510	636	22	620	686	545	592	313	120	620	6	680	65	18	58	84	200	350	395	12-M20
EV-300A	655	535	24	720	660	514	667	315	120	630	-	680	70	20	62.5	89	300	350	445	12-M20
EV-300	600	726	24	760	786	697	595	380	150	739	21	870	90	25	81	170	320	400	445	12-M20

Unit: mm

## EV OVERALL DIMENSION

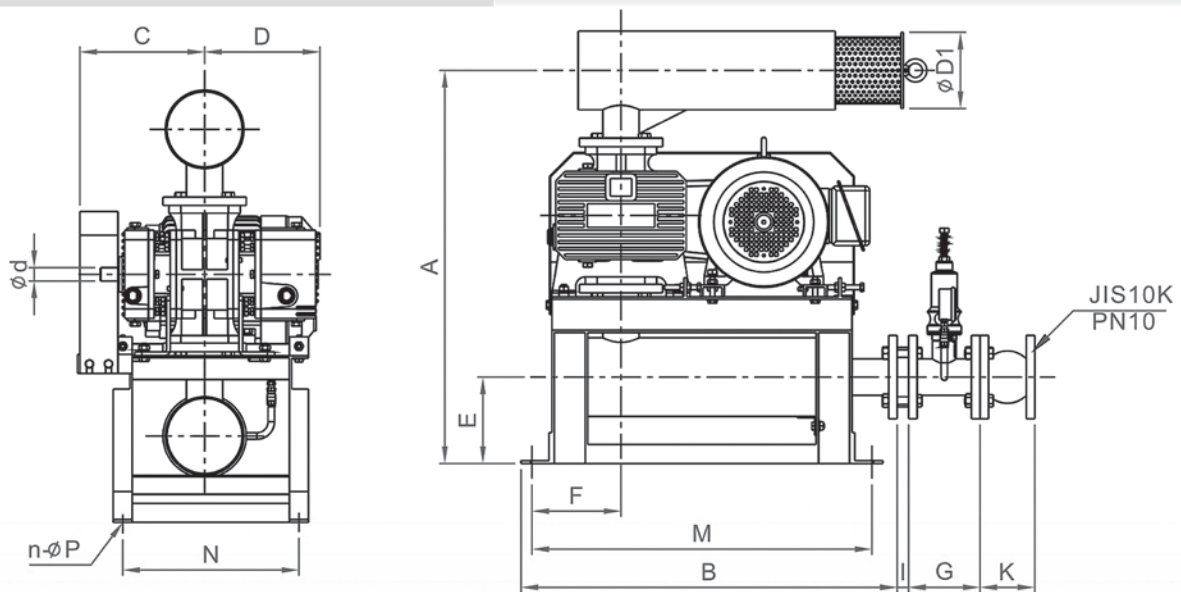

Model	A	B	C	D	φd1	E	F	G	I	K	M	N	φd	n-φP
EV-65	825.5	790	262	242	160	181.5	187	150	24	115	714	370	28	4-φ19
EV-80	1050.5	874	295	282	220	291.5	257	180	24	110	934	450	28	4-φ19
EV-100	1127	990	358	289	233	285	247	180	22	136	1044	560	38	4-φ19
EV-125	1187	1220	383	314	250	225	247	250	24	174	1044	560	38	4-φ19
EV-150A	1321	1246	445	380	330	211	205	250	26	185	1020	630	48	4-φ19
EV-150	1276	1246	512	460	330	208.5	205	250	26	185	1020	630	48	4-φ19
EV-200	1660	1487.5	545	440	370	320	255	250	27	205	1245	660	60	4-φ22
EV-250	1800	1652.5	603	592.5	400	325	365	250	28	240	1510	735	65	4-φ24
EV-300A	1880	1902.5	685.5	667.5	500	350	445	300	32	260	1775	845	90	4-φ24
EV-300	2030	1950	785	590	500	380	492.5	300	32	260	1825	925	90	4-φ24

Unit: mm

# EVV OVERALL DIMENSION

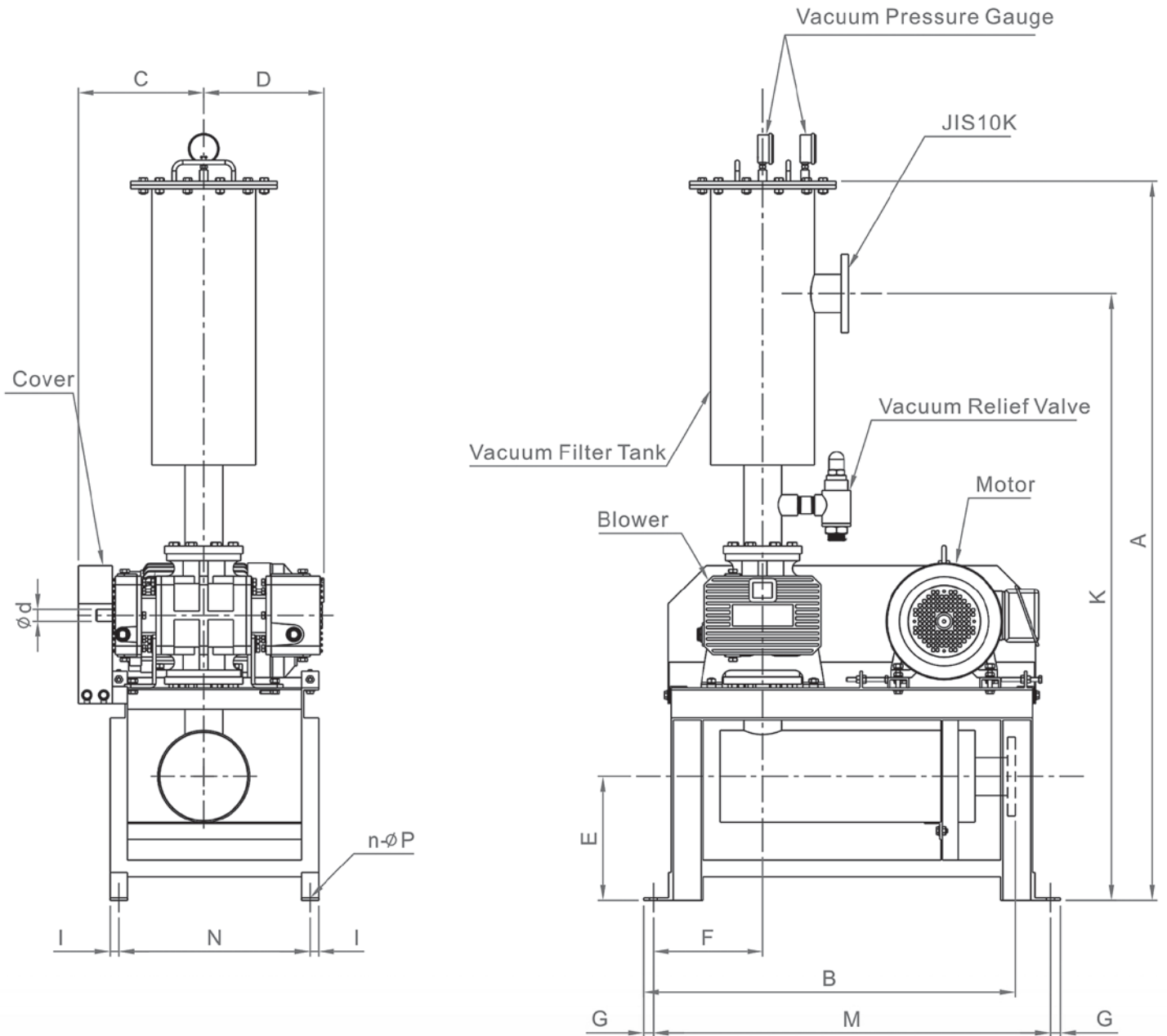

Model	A	B	C	D	$\phi d$	E	F	G	I	K	M	N	$n-\phi P$
EV-65	1323.5	790	262	242	28	181.5	187	23	20	1124.5	714	370	4- $\phi 19$
EV-80	1692.5	874	295	282	28	291.5	257	23	20	1428.5	934	450	4- $\phi 19$
EV-100	1774	990	358	352	38	285	247	23	20	1510	1044	560	4- $\phi 19$
EV-125	1702	1220	383	327	38	225	247	23	20	1507	1044	560	4- $\phi 19$
EV-150A	1906	1260	445	404	48	211	205	50	25	1671	1020	630	4- $\phi 19$
EV-150	1908.5	1260	512	460	48	221	205	50	25	1673.5	1020	630	4- $\phi 19$
EV-200	2245	1487.5	545	597	60	320	255	62.5	20	1940	1245	660	4- $\phi 22$
EV-250	2570	1652.5	603	592.5	65	325	365	32.5	32.5	2270	1510	735	4- $\phi 24$
EV-300A	2780	1952.5	695	673	70	350	495	37.5	37.5	1530	1775	920	4- $\phi 24$
EV-300	2889	1925	792	595	90	371	467.5	37.5	37.5	2539	1825	925	4- $\phi 24$

# EV PERFORMANCE TABLE

NOTE : inlet flow rate  $Q_s = m^3/min$

Model	RPM	Type EV-65 performance																					
		1000mmAq		2000mmAq		3000mmAq		4000mmAq		5000mmAq		6000mmAq		7000mmAq		8000mmAq		9000mmAq		10000mmAq			
		Qs	kw	Qs	kw	Qs	kw	Qs	kw	Qs	kw	Qs	kw	Qs	kw	Qs	kw	Qs	kw	Qs	kw		
65	1950	2.74	0.96	2.61	1.46	2.51	1.96	2.43	2.46	2.36	2.96	2.29	3.46	2.23	3.96	2.17	4.46	2.12	4.96	2.07	5.45		
	2050	2.90	1.01	2.77	1.54	2.67	2.06	2.59	2.58	2.51	3.11	2.45	3.63	2.38	4.16	2.33	4.68	2.27	5.21	2.22	5.73		
	2150	3.06	1.06	2.93	1.61	2.83	2.16	2.74	2.71	2.67	3.26	2.60	3.81	2.54	4.36	2.48	4.91	2.43	5.46	2.38	6.01		
	2250	3.21	1.11	3.08	1.69	2.98	2.26	2.90	2.84	2.83	3.41	2.76	3.99	2.70	4.57	2.64	5.14	2.59	5.72	2.54	6.29		
	2350	3.37	1.16	3.24	1.76	3.14	2.36	3.06	2.96	2.98	3.56	2.92	4.17	2.85	4.77	2.80	5.37	2.74	5.97	2.69	6.57		
	2450	3.53	1.21	3.40	1.83	3.30	2.46	3.21	3.09	3.14	3.72	3.07	4.34	3.01	4.97	2.95	5.60	2.90	6.23	2.85	6.85		
	2550	3.68	1.26	3.55	1.91	3.45	2.56	3.37	3.22	3.30	3.87	3.23	4.52	3.17	5.17	3.11	5.83	3.06	6.48	3.01	7.13		
	2650	3.84	1.31	3.71	1.98	3.61	2.66	3.53	3.34	3.45	4.02	3.39	4.70	3.32	5.38	3.27	6.06	3.21	6.73	3.16	7.41		
	2750	4.00	1.36	3.87	2.06	3.77	2.76	3.68	3.47	3.61	4.17	3.54	4.88	3.48	5.58	3.42	6.28	3.37	6.99	3.32	7.69		
	2850	4.15	1.40	4.02	2.13	3.92	2.86	3.84	3.59	3.77	4.32	3.70	5.05	3.64	5.78	3.58	6.51	3.53	7.24	3.48	7.97		
	2950	4.31	1.45	4.18	2.21	4.08	2.96	4.00	3.72	3.92	4.48	3.86	5.23	3.79	5.99	3.74	6.74	3.68	7.50	3.63	8.25		
	3050	4.47	1.50	4.34	2.28	4.24	3.07	4.15	3.85	4.08	4.63	4.01	5.41	3.95	6.19	3.89	6.97	3.84	7.75	3.79	8.53		
	3150	4.62	1.55	4.49	2.36	4.39	3.17	4.31	3.97	4.24	4.78	4.17	5.59	4.11	6.39	4.05	7.20	4.00	8.00	3.95	8.81		
	3250	4.78	1.60	4.65	2.43	4.55	3.27	4.47	4.10	4.39	4.93	4.33	5.76	4.27	6.59	4.21	7.43	4.15	8.26	4.10	9.09		
	3350	4.94	1.65	4.81	2.51	4.71	3.37	4.62	4.22	4.55	5.08	4.48	5.94	4.42	6.80	4.36	7.66	4.31	8.51	4.26	9.37		
3450	5.09	1.70	4.96	2.58	4.86	3.47	4.78	4.35	4.71	5.23	4.64	6.12	4.58	7.00	4.52	7.88	4.47	8.77	4.42	9.65			

Model	RPM	Type EV-80 performance																					
		1000mmAq		2000mmAq		3000mmAq		4000mmAq		5000mmAq		6000mmAq		7000mmAq		8000mmAq		9000mmAq		10000mmAq			
		Qs	kw	Qs	kw	Qs	kw	Qs	kw	Qs	kw	Qs	kw	Qs	kw	Qs	kw	Qs	kw	Qs	kw		
80	1950	4.69	1.40	4.52	2.23	4.39	3.06	4.28	3.89	4.18	4.73	4.10	5.56	4.02	6.39	3.94	7.22	3.87	8.06	3.81	8.89		
	2050	4.95	1.47	4.78	2.35	4.65	3.22	4.54	4.09	4.44	4.97	4.36	5.84	4.28	6.72	4.20	7.59	4.13	8.47	4.07	9.34		
	2150	5.21	1.54	5.04	2.46	4.91	3.38	4.80	4.29	4.71	5.21	4.62	6.13	4.54	7.05	4.46	7.96	4.39	8.88	4.33	9.80		
	2250	5.47	1.61	5.30	2.57	5.17	3.53	5.06	4.49	4.97	5.45	4.88	6.41	4.80	7.37	4.73	8.33	4.66	9.29	4.59	10.25		
	2350	5.73	1.69	5.56	2.69	5.43	3.69	5.32	4.69	5.23	5.70	5.14	6.70	5.06	7.70	4.99	8.70	4.92	9.71	4.85	10.71		
	2450	5.99	1.76	5.82	2.80	5.70	3.85	5.59	4.89	5.49	5.94	5.40	6.98	5.32	8.03	5.25	9.08	5.18	10.12	5.11	11.17		
	2550	6.25	1.83	6.09	2.92	5.96	4.01	5.85	5.09	5.75	6.18	5.66	7.27	5.58	8.36	5.51	9.45	5.44	10.53	5.37	11.62		
	2650	6.52	1.90	6.35	3.03	6.22	4.16	6.11	5.29	6.01	6.42	5.93	7.55	5.85	8.69	5.77	9.82	5.70	10.95	5.64	12.08		
	2750	6.78	1.97	6.61	3.15	6.48	4.32	6.37	5.49	6.27	6.67	6.19	7.84	6.11	9.01	6.03	10.19	5.96	11.36	5.90	12.53		
	2850	7.04	2.04	6.87	3.26	6.74	4.48	6.63	5.69	6.53	6.91	6.45	8.12	6.37	9.34	6.29	10.56	6.22	11.77	6.16	12.99		
	2950	7.30	2.12	7.13	3.37	7.00	4.63	6.89	5.89	6.80	7.15	6.71	8.41	6.63	9.67	6.55	10.93	6.48	12.19	6.42	13.45		
	3050	7.56	2.19	7.39	3.49	7.26	4.79	7.15	6.09	7.06	7.39	6.97	8.69	6.89	10.00	6.82	11.30	6.75	12.60	6.68	13.90		
	3150	7.82	2.26	7.65	3.60	7.52	4.95	7.41	6.29	7.32	7.64	7.23	8.98	7.15	10.32	7.08	11.67	7.01	13.01	6.94	14.36		
	3250	8.08	2.33	7.91	3.72	7.79	5.10	7.68	6.49	7.58	7.88	7.49	9.27	7.41	10.65	7.34	12.04	7.27	13.43	7.20	14.81		
	3350	8.34	2.40	8.18	3.83	8.05	5.26	7.94	6.69	7.84	8.12	7.75	9.55	7.67	10.98	7.60	12.41	7.53	13.84	7.46	15.27		
	3450	8.61	2.47	8.44	3.95	8.31	5.42	8.20	6.89	8.10	8.36	8.02	9.84	7.94	11.31	7.86	12.78	7.79	14.25	7.73	15.72		
	3550	8.87	2.55	8.70	4.06	8.57	5.58	8.46	7.09	8.36	8.61	8.28	10.12	8.20	11.64	8.12	13.15	8.05	14.66	7.99	16.18		
	3650	9.13	2.62	8.96	4.18	8.83	5.73	8.72	7.29	8.62	8.85	8.54	10.41	8.46	11.96	8.38	13.52	8.31	15.08	8.25	16.64		
	3750	9.39	2.69	9.22	4.29	9.09	5.89	8.98	7.49	8.89	9.09	8.80	10.69	8.72	12.29	8.64	13.89	8.57	15.49	8.51	17.09		
3850	9.65	2.76	9.48	4.40	9.35	6.05	9.24	7.69	9.15	9.33	9.06	10.98	8.98	12.62	8.91	14.26	8.84	15.90	8.77	17.55			
3950	9.91	2.83	9.74	4.52	9.61	6.20	9.50	7.89	9.41	9.58	9.32	11.26	9.24	12.95	9.17	14.63	9.10	16.32	9.03	18.00			

Model	RPM	Type EV-100 performance																					
		1000mmAq		2000mmAq		3000mmAq		4000mmAq		5000mmAq		6000mmAq		7000mmAq		8000mmAq		9000mmAq		10000mmAq			
		Qs	kw	Qs	kw	Qs	kw	Qs	kw	Qs	kw	Qs	kw	Qs	kw	Qs	kw	Qs	kw	Qs	kw		
100	2050	9.22	2.67	8.97	4.28	8.78	5.88	8.62	7.49	8.48	9.09	8.35	10.70	8.23	12.30	8.12	13.91	8.02	15.51	7.92	17.12		
	2150	9.70	2.81	9.45	4.49	9.26	6.17	9.10	7.85	8.96	9.54	8.83	11.22	8.71	12.90	8.60	14.59	8.50	16.27	8.40	17.95		
	2250	10.18	2.94	9.93	4.70	9.74	6.46	9.58	8.22	9.44	9.98	9.31	11.74	9.19	13.50	9.08	15.27	8.98	17.03	8.88	18.79		
	2350	10.66	3.07	10.41	4.91	10.22	6.75	10.06	8.59	9.92	10.43	9.79	12.27	9.67	14.10	9.56	15.94	9.46	17.78	9.36	19.62		
	2450	11.14	3.20	10.89	5.11	10.70	7.03	10.54	8.95	10.40	10.87	10.27	12.79	10.15	14.71	10.04	16.62	9.94	18.54	9.84	20.46		
	2550	11.62	3.33	11.37	5.32	11.18	7.32	11.02	9.32	10.88	11.31	10.75	13.31	10.63	15.31	10.52	17.30	10.42	19.30	10.32	21.29		
	2650	12.10	3.46	11.85	5.53	11.66	7.61	11.50	9.68	11.35	11.76	11.23	13.83	11.11	15.91	11.00	17.98	10.89	20.05	10.80	22.13		
	2750	12.58	3.59	12.33	5.74	12.14	7.89	11.98	10.05	11.83	12.20	11.71	14.35	11.59	16.51	11.48	18.66	11.37	20.81	11.28	22.96		
	2850	13.06	3.72	12.81	5.95	12.62	8.18	12.46	10.41	12.31	12.64	12.19	14.87	12.07	17.11	11.96	19.34	11.85	21.57	11.76	23.80		
	2950	13.54	3.85	13.29	6.16	13.10	8.47	12.94	10.78	12.79	13.09	12.66	15.40	12.55	17.71	12.44	20.02	12.33	22.33	12.24	24.63		
	3050	14.02	3.98	13.77	6.37	13.58	8.76	13.41	11.14	13.27	13.53	13.14	15.92	13.03	18.31	12.92	20.69	12.81	23.08	12.71	25.47		
	3150	14.50	4.11	14.25	6.58	14.06	9.04	13.89	11.51	13.75	13.97	13.62	16.44	13.50	18.91	13.39	21.37	13.29	23.84	13.19	26.30		
	3250	14.98	4.24	14.73	6.78	14.53	9.33	14.37	11.87	14.23	14.42	14.10	16.96	13.98	19.51	13.87	22.05	13.77	24.60	13.67	27.14		
	3350	15.45	4.37	15.21	6.99	15.01	9.62	14.85	12.24	14.71	14.86	14.58	17.48	14.46	20.11	14.35	22.73	14.25	25.35	14.15	27.97		
	3450	15.93	4.50	15.68	7.20	15.49	9.90	15.33	12.60	15.19	15.31	15.06	18.01	14.94	20.71	14.83	23.41	14.73	26.11	14.63	28.81		
	3550	16.41	4.63	16.16	7.41	15.97	10.19	15.81	12.97	15.67	15.75	15.54	18.53	15.42	21.31	15.31	24.09	15.21	26.87	15.11	29.64		
	3650	16.89	4.76	16.64	7.62	16.45	10.48	16.29	13.33	16.15	16.19	16.02	19.05	15.90	21.91	15.79	24.76	15.69	27.62	15.59	30.48		
3750	17.37	4.89	17.12	7.83	16.93	10.76	16.77	13.70	16.63	16.64	16.50	19.57	16.38	22.51	16.27	25.44	16.17	28.38	16.07	31.32			

# EV PERFORMANCE TABLE

NOTE : inlet flow rate  $Q_s = m^3/min$

Model	RPM	Type EV-125 performance																					
		1000mmAq		2000mmAq		3000mmAq		4000mmAq		5000mmAq		6000mmAq		7000mmAq		8000mmAq		9000mmAq		10000mmAq			
		Qs	kw	Qs	kw	Qs	kw	Qs	kw	Qs	kw	Qs	kw	Qs	kw	Qs	kw	Qs	kw	Qs	kw		
125	2050	11.60	3.34	11.32	5.35	11.11	7.36	10.93	9.36	10.76	11.37	10.62	13.37	10.49	15.38	10.36	17.39	10.25	19.39	10.14	21.40		
	2150	12.20	3.51	11.92	5.61	11.71	7.71	11.52	9.82	11.36	11.92	11.22	14.03	11.09	16.13	10.96	18.23	10.85	20.34	10.74	22.44		
	2250	12.80	3.67	12.52	5.87	12.31	8.07	12.12	10.28	11.96	12.48	11.82	14.68	11.69	16.88	11.56	19.08	11.44	21.28	11.33	23.49		
	2350	13.40	3.83	13.12	6.13	12.90	8.43	12.72	10.73	12.56	13.03	12.42	15.33	12.28	17.63	12.16	19.93	12.04	22.23	11.93	24.53		
	2450	14.00	4.00	13.72	6.39	13.50	8.79	13.32	11.19	13.16	13.59	13.02	15.98	12.88	18.38	12.76	20.78	12.64	23.18	12.53	25.57		
	2550	14.60	4.16	14.32	6.65	14.10	9.15	13.92	11.65	13.76	14.14	13.62	16.64	13.48	19.13	13.36	21.63	13.24	24.12	13.13	26.62		
	2650	15.20	4.32	14.92	6.92	14.70	9.51	14.52	12.10	14.36	14.70	14.21	17.29	14.08	19.88	13.96	22.48	13.84	25.07	13.73	27.66		
	2750	15.80	4.49	15.52	7.18	15.30	9.87	15.12	12.56	14.96	15.25	14.81	17.94	14.68	20.63	14.56	23.32	14.44	26.01	14.33	28.71		
	2850	16.40	4.65	16.12	7.44	15.90	10.23	15.72	13.02	15.56	15.80	15.41	18.59	15.28	21.38	15.16	24.17	15.04	26.96	14.93	29.75		
	2950	17.00	4.81	16.71	7.70	16.50	10.59	16.32	13.47	16.16	16.36	16.01	19.25	15.88	22.13	15.76	25.02	15.64	27.91	15.53	30.79		
	3050	17.60	4.97	17.31	7.96	17.10	10.94	16.92	13.93	16.76	16.91	16.61	19.90	16.48	22.88	16.35	25.87	16.24	28.85	16.13	31.84		
	3150	18.19	5.14	17.91	8.22	17.70	11.30	17.52	14.39	17.36	17.47	17.21	20.55	17.08	23.63	16.95	26.72	16.84	29.80	16.73	32.88		
	3250	18.79	5.30	18.51	8.48	18.30	11.66	18.11	14.84	17.95	18.02	17.81	21.20	17.68	24.38	17.55	27.56	17.44	30.74	17.33	33.92		
	3350	19.39	5.46	19.11	8.74	18.90	12.02	18.71	15.30	18.55	18.58	18.41	21.86	18.28	25.13	18.15	28.41	18.04	31.69	17.93	34.97		
	3450	19.99	5.63	19.71	9.00	19.49	12.38	19.31	15.76	19.15	19.13	19.01	22.51	18.87	25.88	18.75	29.26	18.63	32.64	18.52	36.01		
3550	20.59	5.79	20.31	9.26	20.09	12.74	19.91	16.21	19.75	19.69	19.61	23.16	19.47	26.63	19.35	30.11	19.23	33.58	19.12	37.06			

Model	RPM	Type EV-150A performance																					
		1000mmAq		2000mmAq		3000mmAq		4000mmAq		5000mmAq		6000mmAq		7000mmAq		8000mmAq		9000mmAq		10000mmAq			
		Qs	kw	Qs	kw	Qs	kw	Qs	kw	Qs	kw	Qs	kw	Qs	kw	Qs	kw	Qs	kw	Qs	kw		
150A	1650	19.17	5.52	18.71	8.84	18.36	12.15	18.06	15.46	17.79	18.78	17.55	22.09	17.34	25.40	17.13	28.72	16.94	32.03	16.76	35.35		
	1750	20.40	5.86	19.94	9.37	19.58	12.89	19.29	16.40	19.02	19.92	18.78	23.43	18.57	26.94	18.36	30.46	18.17	33.97	17.99	37.49		
	1850	21.63	6.19	21.17	9.91	20.81	13.62	20.52	17.34	20.25	21.05	20.01	24.77	19.79	28.48	19.59	32.20	19.40	35.91	19.22	39.63		
	1950	22.86	6.53	22.40	10.44	22.04	14.36	21.74	18.28	21.48	22.19	21.24	26.11	21.02	30.02	20.82	33.94	20.63	37.86	20.45	41.77		
	2050	24.09	6.86	23.63	10.98	23.27	15.10	22.97	19.21	22.71	23.33	22.47	27.45	22.25	31.56	22.05	35.68	21.86	39.80	21.68	43.91		
	2150	25.32	7.20	24.86	11.51	24.50	15.83	24.20	20.15	23.94	24.47	23.70	28.79	23.48	33.10	23.28	37.42	23.09	41.74	22.91	46.06		
	2250	26.55	7.53	26.09	12.05	25.73	16.57	25.43	21.09	25.17	25.61	24.93	30.12	24.71	34.64	24.51	39.16	24.32	43.68	24.14	48.20		
	2350	27.78	7.87	27.32	12.59	26.96	17.30	26.66	22.02	26.40	26.74	26.16	31.46	25.94	36.18	25.74	40.90	25.55	45.62	25.37	50.34		
	2450	29.01	8.20	28.55	13.12	28.19	18.04	27.89	22.96	27.63	27.88	27.39	32.80	27.17	37.72	26.97	42.64	26.78	47.56	26.60	52.48		
	2550	30.24	8.54	29.78	13.66	29.42	18.78	29.12	23.90	28.86	29.02	28.62	34.14	28.40	39.26	28.20	44.38	28.01	49.50	27.83	54.63		
	2650	31.47	8.87	31.01	14.19	30.65	19.51	30.35	24.84	30.09	30.16	29.85	35.48	29.63	40.80	29.43	46.12	29.24	51.45	29.06	56.77		
	2750	32.70	9.20	32.23	14.73	31.88	20.25	31.58	25.77	31.32	31.30	31.08	36.82	30.86	42.34	30.66	47.86	30.47	53.39	30.28	58.91		
	2850	33.93	9.54	33.46	15.26	33.11	20.99	32.81	26.71	32.55	32.43	32.31	38.16	32.09	43.88	31.89	49.60	31.70	55.33	31.51	61.05		
	2950	35.16	9.87	34.69	15.80	34.34	21.72	34.04	27.65	33.78	33.57	33.54	39.50	33.32	45.42	33.12	51.34	32.92	57.27	32.74	63.19		
	3050	36.39	10.21	35.92	16.33	35.57	22.46	35.27	28.58	35.01	34.71	34.77	40.83	34.55	46.96	34.35	53.09	34.15	59.21	33.97	65.34		
	3150	37.62	10.54	37.15	16.87	36.80	23.20	36.50	29.52	36.24	35.85	36.00	42.17	35.78	48.50	35.58	54.83	35.38	61.15	35.20	67.48		
	3250	38.84	10.88	38.38	17.41	38.03	23.93	37.73	30.46	37.47	36.99	37.23	43.51	37.01	50.04	36.80	56.57	36.61	63.09	36.43	69.62		
	3350	40.07	11.21	39.61	17.94	39.26	24.67	38.96	31.40	38.70	38.12	38.46	44.85	38.24	51.58	38.03	58.31	37.84	65.03	37.66	71.76		
3450	41.30	11.55	40.84	18.48	40.49	25.40	40.19	32.33	39.92	39.26	39.69	46.19	39.47	53.12	39.26	60.05	39.07	66.98	38.89	73.90			
3550	42.53	11.88	42.07	19.01	41.72	26.14	41.42	33.27	41.15	40.40	40.92	47.53	40.70	54.66	40.49	61.79	40.30	68.92	40.12	76.05			

Model	RPM	Type EV-150 performance																					
		1000mmAq		2000mmAq		3000mmAq		4000mmAq		5000mmAq		6000mmAq		7000mmAq		8000mmAq		9000mmAq		10000mmAq			
		Qs	kw	Qs	kw	Qs	kw	Qs	kw	Qs	kw	Qs	kw	Qs	kw	Qs	kw	Qs	kw	Qs	kw		
150	1650	28.40	8.07	27.88	12.91	27.48	17.76	27.15	22.60	26.85	27.44	26.58	32.29	26.34	37.13	26.11	41.97	25.89	46.82	25.69	51.66		
	1750	30.20	8.56	29.68	13.70	29.28	18.83	28.94	23.97	28.65	29.11	28.38	34.24	28.13	39.38	27.90	44.52	27.69	49.65	27.49	54.79		
	1850	31.99	9.05	31.47	14.48	31.08	19.91	30.74	25.34	30.44	30.77	30.18	36.20	29.93	41.63	29.70	47.06	29.49	52.49	29.28	57.92		
	1950	33.79	9.54	33.27	15.26	32.87	20.99	32.54	26.71	32.24	32.43	31.97	38.16	31.73	43.88	31.50	49.60	31.28	55.33	31.08	61.05		
	2050	35.59	10.03	35.07	16.05	34.67	22.06	34.33	28.08	34.04	34.10	33.77	40.11	33.52	46.13	33.30	52.15	33.08	58.17	32.88	64.18		
	2150	37.38	10.52	36.86	16.83	36.47	23.14	36.13	29.45	35.83	35.76	35.57	42.07	35.32	48.38	35.09	54.69	34.88	61.00	34.67	67.31		
	2250	39.18	11.01	38.66	17.61	38.26	24.22	37.93	30.82	37.63	37.42	37.36	44.03	37.12	50.63	36.89	57.24	36.67	63.84	36.47	70.44		
	2350	40.98	11.50	40.46	18.39	40.06	25.29	39.72	32.19	39.43	39.09	39.16	45.98	38.92	52.88	38.69	59.78	38.47	66.68	38.27	73.57		
	2450	42.77	11.99	42.26	19.18	41.86	26.37	41.52	33.56	41.23	40.75	40.96	47.94	40.71	55.13	40.48	62.32	40.27	69.51	40.07	76.71		
	2550	44.57	12.47	44.05	19.96	43.65	27.44	43.32	34.93	43.02	42.41	42.76	49.90	42.51	57.38	42.28	64.87	42.07	72.35	41.86	79.84		
	2650	46.37	12.96	45.85	20.74	45.45	28.52	45.12	36.30	44.82	44.08	44.55	51.85	44.31	59.63	44.08	67.41	43.86	75.19	43.66	82.97		
	2750	48.17	13.45	47.65	21.52	47.25	29.60	46.91	37.67	46.62	45.74	46.35	53.81	46.10	61.88	45.87	69.95	45.66	78.03	45.46	86.10		

# EV PERFORMANCE TABLE

NOTE : inlet flow rate  $Q_s = m^3/min$

Model	RPM	Type EV-200 performance																					
		1000mmAq		2000mmAq		3000mmAq		4000mmAq		5000mmAq		6000mmAq		7000mmAq		8000mmAq		9000mmAq		10000mmAq			
		Qs	kw	Qs	kw	Qs	kw	Qs	kw	Qs	kw	Qs	kw	Qs	kw	Qs	kw	Qs	kw	Qs	kw		
200	1470	33.69	9.71	32.88	15.53	32.26	21.35	31.74	27.17	31.27	33.00	30.86	38.82	30.47	44.64	30.12	50.47	29.78	56.29	29.46	62.11		
	1560	35.88	10.30	35.07	16.48	34.44	22.66	33.92	28.84	33.46	35.02	33.04	41.20	32.66	47.38	32.30	53.56	31.96	59.74	31.64	65.92		
	1650	38.06	10.89	37.25	17.43	36.63	23.97	36.10	30.50	35.64	37.04	35.22	43.57	34.84	50.11	34.48	56.65	34.15	63.18	33.83	69.72		
	1750	40.49	11.55	39.67	18.49	39.05	25.42	38.53	32.35	38.07	39.28	37.65	46.22	37.26	53.15	36.91	60.08	36.57	67.01	36.25	73.94		
	1850	42.91	12.21	42.10	19.54	41.48	26.87	40.95	34.20	40.49	41.53	40.07	48.86	39.69	56.18	39.33	63.51	39.00	70.84	38.68	78.17		
	1950	45.34	12.87	44.52	20.60	43.90	28.32	43.38	36.05	42.92	43.77	42.50	51.50	42.11	59.22	41.76	66.95	41.42	74.67	41.10	82.39		
	2050	47.76	13.53	46.95	21.66	46.33	29.78	45.80	37.90	45.34	46.02	44.92	54.14	44.54	62.26	44.18	70.38	43.85	78.50	43.53	86.62		
	2150	50.19	14.19	49.38	22.71	48.75	31.23	48.23	39.74	47.77	48.26	47.35	56.78	46.96	65.30	46.61	73.81	46.27	82.33	45.95	90.85		
	2250	52.61	14.85	51.80	23.77	51.18	32.68	50.65	41.59	50.19	50.51	49.77	59.42	49.39	68.33	49.03	77.25	48.70	86.16	48.38	95.07		
	2350	55.04	15.52	54.23	24.82	53.60	34.13	53.08	43.44	52.62	52.75	52.20	62.06	51.82	71.37	51.46	80.68	51.12	89.99	50.80	99.30		
	2450	57.46	16.18	56.65	25.88	56.03	35.59	55.50	45.29	55.04	55.00	54.62	64.70	54.24	74.41	53.88	84.11	53.55	93.82	53.23	103.52		
	2550	59.89	16.84	59.08	26.94	58.45	37.04	57.93	47.14	57.47	57.24	57.05	67.34	56.67	77.44	56.31	87.54	55.97	97.65	55.65	107.75		
2650	62.31	17.50	61.50	27.99	60.88	38.49	60.36	48.99	59.89	59.49	59.48	69.98	59.09	80.48	58.73	90.98	58.40	101.47	58.08	111.97			

Model	RPM	Type EV-250 performance																					
		1000mmAq		2000mmAq		3000mmAq		4000mmAq		5000mmAq		6000mmAq		7000mmAq		8000mmAq		9000mmAq		10000mmAq			
		Qs	kw	Qs	kw	Qs	kw	Qs	kw	Qs	kw	Qs	kw	Qs	kw	Qs	kw	Qs	kw	Qs	kw		
250	1320	60.63	17.17	59.62	27.48	58.84	37.78	58.18	48.08	57.61	58.38	57.08	68.69	56.60	78.99	56.16	89.29	55.74	99.60	55.34	109.90		
	1390	63.98	18.08	62.96	28.93	62.19	39.78	61.53	50.63	60.95	61.48	60.43	72.33	59.95	83.18	59.50	94.03	59.08	104.88	58.68	115.73		
	1480	68.28	19.25	67.26	30.81	66.49	42.36	65.83	53.91	65.25	65.46	64.73	77.01	64.25	88.57	63.80	100.12	63.38	111.67	62.99	123.22		
	1560	72.10	20.29	71.09	32.47	70.31	44.65	69.65	56.82	69.08	69.00	68.55	81.18	68.07	93.35	67.63	105.53	67.21	117.71	66.81	129.88		
	1650	76.40	21.46	75.39	34.34	74.61	47.22	73.95	60.10	73.38	72.98	72.85	85.86	72.37	98.74	71.93	116.62	71.51	124.50	71.11	137.38		
	1750	81.18	22.77	80.17	36.43	79.39	50.08	78.73	63.74	78.16	77.40	77.63	91.06	77.15	104.72	76.71	118.38	76.29	132.04	75.89	145.70		
	1850	85.96	24.07	84.95	38.51	84.17	52.95	83.51	67.39	82.93	81.83	82.41	96.27	81.93	110.71	81.48	125.15	81.06	139.59	80.67	154.03		
	1950	90.74	25.37	89.73	40.59	88.95	55.81	88.29	71.03	87.71	86.25	87.19	101.47	86.71	116.69	86.26	131.91	85.84	147.13	85.45	162.35		
	2050	95.52	26.67	94.50	42.67	93.73	58.67	93.07	74.67	92.49	90.67	91.97	106.67	91.49	122.68	91.04	138.68	90.62	154.68	90.23	170.68		
	2150	100.30	27.97	99.28	44.75	98.51	61.53	97.85	78.31	97.27	95.10	96.75	111.88	96.27	128.66	95.82	145.44	95.40	162.22	95.00	179.00		

Model	RPM	Type EV-300A performance																					
		1000mmAq		2000mmAq		3000mmAq		4000mmAq		5000mmAq		6000mmAq		7000mmAq		8000mmAq		9000mmAq		10000mmAq			
		Qs	kw	Qs	kw	Qs	kw	Qs	kw	Qs	kw	Qs	kw	Qs	kw	Qs	kw	Qs	kw	Qs	kw		
300A	1050	64.04	18.21	62.85	29.14	61.94	40.07	61.17	51.00	60.50	61.92	59.88	72.85	59.32	83.78	58.80	94.71	58.31	105.63	57.84	116.56		
	1110	67.86	19.25	66.67	30.81	65.76	42.36	64.99	53.91	64.32	65.46	63.71	77.01	63.14	88.57	62.62	100.12	62.13	111.67	61.66	123.22		
	1180	72.32	20.47	71.13	32.75	70.22	45.03	69.46	57.31	68.78	69.59	68.17	81.87	67.60	94.15	67.08	106.43	66.59	118.71	66.12	130.99		
	1250	76.78	21.68	75.59	34.69	74.68	47.70	73.92	60.71	73.24	73.72	72.63	86.73	72.06	99.74	71.54	112.75	71.05	125.75	70.58	138.76		
	1320	81.24	22.90	80.05	36.63	79.14	50.37	78.38	64.11	77.70	77.85	77.09	91.58	76.53	105.32	76.00	119.06	75.51	132.80	75.04	146.53		
	1390	85.70	24.11	84.51	38.58	83.60	53.04	82.84	67.51	82.16	81.97	81.55	96.44	80.99	110.91	80.46	125.37	79.97	139.84	79.50	154.30		
	1480	91.44	25.67	90.25	41.07	89.34	56.48	88.57	71.88	87.89	87.28	87.28	102.68	86.72	118.09	86.20	133.49	85.70	148.89	85.24	164.30		
	1560	96.53	27.06	95.35	43.29	94.44	59.53	93.67	75.76	92.99	92.00	92.38	108.24	91.82	124.47	91.29	140.71	90.80	156.94	90.34	173.18		
	1650	102.27	28.62	101.08	45.79	100.17	62.96	99.40	80.14	98.73	97.31	98.11	114.48	97.55	131.65	97.03	148.82	96.54	166.00	96.07	183.17		
	1750	108.64	30.35	107.45	48.57	106.54	66.78	105.77	84.99	105.10	103.21	104.49	121.42	103.92	139.63	103.40	157.84	102.91	176.06	102.44	194.27		
	1850	115.01	32.09	113.82	51.34	112.91	70.60	112.15	89.85	111.47	109.10	110.86	128.36	110.30	147.61	109.77	166.86	109.28	186.12	108.82	205.37		

Model	RPM	Type EV-300 performance																					
		1000mmAq		2000mmAq		3000mmAq		4000mmAq		5000mmAq		6000mmAq		7000mmAq		8000mmAq		9000mmAq		10000mmAq			
		Qs	kw	Qs	kw	Qs	kw	Qs	kw	Qs	kw	Qs	kw	Qs	kw	Qs	kw	Qs	kw	Qs	kw		
300	1050	91.19	25.88	89.58	41.40	88.35	56.93	87.31	72.46	86.40	87.98	85.57	103.51	84.81	119.04	84.10	134.56	83.44	150.09	82.81	165.62		
	1110	96.62	27.36	95.01	43.77	93.78	60.18	92.74	76.60	91.83	93.01	91.00	109.42	90.24	125.84	89.53	142.25	88.87	158.67	88.24	175.08		
	1180	102.95	29.08	101.35	46.53	100.12	63.98	99.08	81.43	98.17	98.88	97.34	116.32	96.58	133.77	95.87	151.22	95.21	168.67	94.58	186.12		
	1250	109.29	30.81	107.69	49.29	106.46	67.77	105.42	86.26	104.50	104.74	103.68	123.23	102.92	141.71	102.21	160.19	101.54	178.68	100.92	197.16		
	1320	115.63	32.53	114.02	52.05	112.79	71.57	111.76	91.09	110.84	110.61	110.01	130.13	109.25	149.65	108.55	169.16	107.88	188.68	107.25	208.20		
	1390	121.97	34.26	120.36	54.81	119.13	75.36	118.09	95.92	117.18	116.47	116.35	137.03	115.59	157.58	114.88	178.13	114.22	198.69	113.59	219.24		
	1480	130.11	36.47	128.51	58.36	127.28	80.24	126.24	102.13	125.33	124.01	124.50	145.90	123.74	167.78	123.03	189.67	122.37	211.55	121.74	233.44		
	1560	137.36	38.45	135.75	61.51	134.52	84.58	133.48	107.65	132.57	130.72	131.74	153.79	130.98	176.85	130.27	199.92	129.61	222.99	128.98	246.06		
	1650	145.51	40.66	143.90	65.06	142.67	89.46	141.63	113.86	140.72	138.26	139.89	162.66	139.13	187.06	138.42	211.46	137.76	235.85	137.13	260.25		
	1750	154.56	43.13	152.95	69.01	151.72	94.88	150.68	120.76	149.77	146.64	148.94	172.52	148.18	198.39	147.48	224.27	146.81	250.15	146.18	276.03		
	1850	163.61	45.59	162.01	72.95	160.78	100.31	159.74	127.66	158.82	155.02	158.00	182.37	157.24	209.73	156.53	237.09	155.86	264.44	155.24	291.80		

# EVV PERFORMANCE TABLE

NOTE : inlet flow rate  $Q_s = m^3/min$

Model	RPM	Type EVV-65 performance											
		-1000mmAq		-2000mmAq		-3000mmAq		-4000mmAq		-5000mmAq		-6000mmAq	
		Qs	kw	Qs	kw	Qs	kw	Qs	kw	Qs	kw	Qs	kw
65	1950	2.73	0.96	2.56	1.46	2.41	1.96	2.26	2.46	2.08	2.96	1.60	3.46
	2050	2.88	1.01	2.72	1.54	2.57	2.06	2.41	2.58	2.24	3.11	1.75	3.63
	2150	3.04	1.06	2.88	1.61	2.73	2.16	2.57	2.71	2.39	3.26	1.91	3.81
	2250	3.20	1.11	3.03	1.69	2.88	2.26	2.73	2.84	2.55	3.41	2.07	3.99
	2350	3.35	1.16	3.19	1.76	3.04	2.36	2.88	2.96	2.71	3.56	2.22	4.17
	2450	3.51	1.21	3.35	1.83	3.20	2.46	3.04	3.09	2.86	3.72	2.38	4.34
	2550	3.67	1.26	3.50	1.91	3.35	2.56	3.20	3.22	3.02	3.87	2.54	4.52
	2650	3.82	1.31	3.66	1.98	3.51	2.66	3.35	3.34	3.18	4.02	2.69	4.70
	2750	3.98	1.36	3.82	2.06	3.67	2.76	3.51	3.47	3.34	4.17	2.85	4.88
	2850	4.14	1.40	3.97	2.13	3.82	2.86	3.67	3.59	3.49	4.32	3.01	5.05
	2950	4.29	1.45	4.13	2.21	3.98	2.96	3.82	3.72	3.65	4.48	3.16	5.23
	3050	4.45	1.50	4.29	2.28	4.14	3.07	3.98	3.85	3.81	4.63	3.32	5.41
	3150	4.61	1.55	4.44	2.36	4.29	3.17	4.14	3.97	3.96	4.78	3.48	5.59
	3250	4.76	1.60	4.60	2.43	4.45	3.27	4.29	4.10	4.12	4.93	3.63	5.76
	3350	4.92	1.65	4.76	2.51	4.61	3.37	4.45	4.22	4.28	5.08	3.79	5.94
3450	5.08	1.70	4.91	2.58	4.76	3.47	4.61	4.35	4.43	5.23	3.95	6.12	

Model	RPM	Type EVV-80 performance											
		-1000mmAq		-2000mmAq		-3000mmAq		-4000mmAq		-5000mmAq		-6000mmAq	
		Qs	kw	Qs	kw	Qs	kw	Qs	kw	Qs	kw	Qs	kw
80	1950	4.67	1.40	4.45	2.23	4.26	3.06	4.05	3.89	3.83	4.73	3.55	5.56
	2050	4.93	1.47	4.71	2.35	4.52	3.22	4.32	4.09	4.09	4.97	3.82	5.84
	2150	5.19	1.54	4.98	2.46	4.78	3.38	4.58	4.29	4.35	5.21	4.08	6.13
	2250	5.45	1.61	5.24	2.57	5.04	3.53	4.84	4.49	4.61	5.45	4.34	6.41
	2350	5.71	1.69	5.50	2.69	5.30	3.69	5.10	4.69	4.87	5.70	4.60	6.70
	2450	5.97	1.76	5.76	2.80	5.56	3.85	5.36	4.89	5.13	5.94	4.86	6.98
	2550	6.23	1.83	6.02	2.92	5.82	4.01	5.62	5.09	5.39	6.18	5.12	7.27
	2650	6.49	1.90	6.28	3.03	6.09	4.16	5.88	5.29	5.66	6.42	5.38	7.55
	2750	6.76	1.97	6.54	3.15	6.35	4.32	6.14	5.49	5.92	6.67	5.64	7.84
	2850	7.02	2.04	6.80	3.26	6.61	4.48	6.41	5.69	6.18	6.91	5.91	8.12
	2950	7.28	2.12	7.07	3.37	6.87	4.63	6.67	5.89	6.44	7.15	6.17	8.41
	3050	7.54	2.19	7.33	3.49	7.13	4.79	6.93	6.09	6.70	7.39	6.43	8.69
	3150	7.80	2.26	7.59	3.60	7.39	4.95	7.19	6.29	6.96	7.64	6.69	8.98
	3250	8.06	2.33	7.85	3.72	7.65	5.10	7.45	6.49	7.22	7.88	6.95	9.27
	3350	8.32	2.40	8.11	3.83	7.91	5.26	7.71	6.69	7.48	8.12	7.21	9.55
	3450	8.58	2.47	8.37	3.95	8.18	5.42	7.97	6.89	7.75	8.36	7.47	9.84
	3550	8.85	2.55	8.63	4.06	8.44	5.58	8.23	7.09	8.01	8.61	7.73	10.12
	3650	9.11	2.62	8.89	4.18	8.70	5.73	8.50	7.29	8.27	8.85	8.00	10.41
3750	9.37	2.69	9.16	4.29	8.96	5.89	8.76	7.49	8.53	9.09	8.26	10.69	
3850	9.63	2.76	9.42	4.40	9.22	6.05	9.02	7.69	8.79	9.33	8.52	10.98	
3950	9.89	2.83	9.68	4.52	9.48	6.20	9.28	7.89	9.05	9.58	8.78	11.26	

Model	RPM	Type EVV-100 performance											
		-1000mmAq		-2000mmAq		-3000mmAq		-4000mmAq		-5000mmAq		-6000mmAq	
		Qs	kw	Qs	kw	Qs	kw	Qs	kw	Qs	kw	Qs	kw
100	2050	9.19	2.67	8.88	4.28	8.59	5.88	8.29	7.49	7.95	9.09	7.55	10.70
	2150	9.67	2.81	9.36	4.49	9.07	6.17	8.77	7.85	8.43	9.54	8.03	11.22
	2250	10.15	2.94	9.84	4.70	9.55	6.46	9.25	8.22	8.91	9.98	8.51	11.74
	2350	10.63	3.07	10.32	4.91	10.03	6.75	9.73	8.59	9.39	10.43	8.99	12.27
	2450	11.11	3.20	10.79	5.11	10.50	7.03	10.20	8.95	9.87	10.87	9.47	12.79
	2550	11.59	3.33	11.27	5.32	10.98	7.32	10.68	9.32	10.35	11.31	9.95	13.31
	2650	12.07	3.46	11.75	5.53	11.46	7.61	11.16	9.68	10.83	11.76	10.42	13.83
	2750	12.55	3.59	12.23	5.74	11.94	7.89	11.64	10.05	11.31	12.20	10.90	14.35
	2850	13.03	3.72	12.71	5.95	12.42	8.18	12.12	10.41	11.79	12.64	11.38	14.87
	2950	13.51	3.85	13.19	6.16	12.90	8.47	12.60	10.78	12.27	13.09	11.86	15.40
	3050	13.99	3.98	13.67	6.37	13.38	8.76	13.08	11.14	12.74	13.53	12.34	15.92
	3150	14.46	4.11	14.15	6.58	13.86	9.04	13.56	11.51	13.22	13.97	12.82	16.44
	3250	14.94	4.24	14.63	6.78	14.34	9.33	14.04	11.87	13.70	14.42	13.30	16.96
	3350	15.42	4.37	15.11	6.99	14.82	9.62	14.52	12.24	14.18	14.86	13.78	17.48
	3450	15.90	4.50	15.59	7.20	15.30	9.90	15.00	12.60	14.66	15.31	14.26	18.01
	3550	16.38	4.63	16.07	7.41	15.78	10.19	15.48	12.97	15.14	15.75	14.74	18.53
	3650	16.86	4.76	16.55	7.62	16.26	10.48	15.96	13.33	15.62	16.19	15.22	19.05
	3750	17.34	4.89	17.03	7.83	16.74	10.76	16.44	13.70	16.10	16.64	15.70	19.57
3850	17.82	5.02	17.51	8.04	17.22	11.05	16.92	14.07	16.58	17.08	16.18	20.09	



# EVV PERFORMANCE TABLE

NOTE : inlet flow rate Qs=m<sup>3</sup>/min

Model	RPM	Type EVV-125 performance											
		-1000mmAq		-2000mmAq		-3000mmAq		-4000mmAq		-5000mmAq		-6000mmAq	
		Qs	kw	Qs	kw	Qs	kw	Qs	kw	Qs	kw	Qs	kw
125	2050	11.57	3.34	11.21	5.35	10.89	7.36	10.55	9.36	10.17	11.37	9.71	13.37
	2150	12.17	3.51	11.81	5.61	11.49	7.71	11.15	9.82	10.77	11.92	10.32	14.03
	2250	12.77	3.67	12.41	5.87	12.09	8.07	11.75	10.28	11.37	12.48	10.91	14.68
	2350	13.37	3.83	13.01	6.13	12.68	8.43	12.35	10.73	11.97	13.03	11.51	15.33
	2450	13.96	4.00	13.61	6.39	13.28	8.79	12.95	11.19	12.57	13.59	12.11	15.98
	2550	14.56	4.16	14.21	6.65	13.88	9.15	13.54	11.65	13.17	14.14	12.71	16.64
	2650	15.16	4.32	14.81	6.92	14.48	9.51	14.14	12.10	13.77	14.70	13.31	17.29
	2750	15.76	4.49	15.41	7.18	15.08	9.87	14.74	12.56	14.36	15.25	13.91	17.94
	2850	16.36	4.65	16.01	7.44	15.68	10.23	15.34	13.02	14.96	15.80	14.51	18.59
	2950	16.96	4.81	16.61	7.70	16.28	10.59	15.94	13.47	15.56	16.36	15.11	19.25
	3050	17.56	4.97	17.21	7.96	16.88	10.94	16.54	13.93	16.16	16.91	15.71	19.90
	3150	18.16	5.14	17.80	8.22	17.48	11.30	17.14	14.39	16.76	17.47	16.31	20.55
	3250	18.76	5.30	18.40	8.48	18.08	11.66	17.74	14.84	17.36	18.02	16.91	21.20
	3350	19.36	5.46	19.00	8.74	18.68	12.02	18.34	15.30	17.96	18.58	17.51	21.86
	3450	19.96	5.63	19.60	9.00	19.28	12.38	18.94	15.76	18.56	19.13	18.10	22.51
3550	20.56	5.79	20.20	9.26	19.87	12.74	19.54	16.21	19.16	19.69	18.70	23.16	

Model	RPM	Type EVV-150A performance											
		-1000mmAq		-2000mmAq		-3000mmAq		-4000mmAq		-5000mmAq		-6000mmAq	
		Qs	kw	Qs	kw	Qs	kw	Qs	kw	Qs	kw	Qs	kw
150A	1650	19.11	5.52	18.53	8.84	17.99	12.15	17.44	15.46	16.82	18.78	16.07	22.09
	1750	20.34	5.86	19.76	9.37	19.22	12.89	18.67	16.40	18.05	19.92	17.30	23.43
	1850	21.57	6.19	20.99	9.91	20.45	13.62	19.90	17.34	19.28	21.05	18.53	24.77
	1950	22.80	6.53	22.22	10.44	21.68	14.36	21.13	18.28	20.50	22.19	19.76	26.11
	2050	24.03	6.86	23.45	10.98	22.91	15.10	22.36	19.21	21.73	23.33	20.99	27.45
	2150	25.26	7.20	24.68	11.51	24.14	15.83	23.59	20.15	22.96	24.47	22.22	28.79
	2250	26.49	7.53	25.91	12.05	25.37	16.57	24.82	21.09	24.19	25.61	23.45	30.12
	2350	27.72	7.87	27.14	12.59	26.60	17.30	26.04	22.02	25.42	26.74	24.68	31.46
	2450	28.95	8.20	28.37	13.12	27.83	18.04	27.27	22.96	26.65	27.88	25.91	32.80
	2550	30.18	8.54	29.60	13.66	29.06	18.78	28.50	23.90	27.88	29.02	27.14	34.14
	2650	31.41	8.87	30.83	14.19	30.29	19.51	29.73	24.84	29.11	30.16	28.36	35.48
	2750	32.64	9.20	32.06	14.73	31.52	20.25	30.96	25.77	30.34	31.30	29.59	36.82
	2850	33.87	9.54	33.29	15.26	32.75	20.99	32.19	26.71	31.57	32.43	30.82	38.16
	2950	35.10	9.87	34.52	15.80	33.98	21.72	33.42	27.65	32.80	33.57	32.05	39.50
	3050	36.33	10.21	35.74	16.33	35.21	22.46	34.65	28.58	34.03	34.71	33.28	40.83
	3150	37.56	10.54	36.97	16.87	36.44	23.20	35.88	29.52	35.26	35.85	34.51	42.17
	3250	38.79	10.88	38.20	17.41	37.67	23.93	37.11	30.46	36.49	36.99	35.74	43.51
	3350	40.02	11.21	39.43	17.94	38.90	24.67	38.34	31.40	37.72	38.12	36.97	44.85
3450	41.25	11.55	40.66	18.48	40.13	25.40	39.57	32.33	38.95	39.26	38.20	46.19	
3550	42.48	11.88	41.89	19.01	41.36	26.14	40.80	33.27	40.18	40.40	39.43	47.53	

Model	RPM	Type EVV-150 performance											
		-1000mmAq		-2000mmAq		-3000mmAq		-4000mmAq		-5000mmAq		-6000mmAq	
		Qs	kw	Qs	kw	Qs	kw	Qs	kw	Qs	kw	Qs	kw
150	1650	28.33	8.07	27.68	12.91	27.08	17.76	26.45	22.60	25.75	27.44	24.91	32.29
	1750	30.13	8.56	29.48	13.70	28.87	18.83	28.25	23.97	27.55	29.11	26.71	34.24
	1850	31.93	9.05	31.27	14.48	30.67	19.91	30.05	25.34	29.35	30.77	28.51	36.20
	1950	33.72	9.54	33.07	15.26	32.47	20.99	31.84	26.71	31.14	32.43	30.31	38.16
	2050	35.52	10.03	34.87	16.05	34.26	22.06	33.64	28.08	32.94	34.10	32.10	40.11
	2150	37.32	10.52	36.66	16.83	36.06	23.14	35.44	29.45	34.74	35.76	33.90	42.07
	2250	39.12	11.01	38.46	17.61	37.86	24.22	37.23	30.82	36.53	37.42	35.70	44.03
	2350	40.91	11.50	40.26	18.39	39.65	25.29	39.03	32.19	38.33	39.09	37.49	45.98
	2450	42.71	11.99	42.05	19.18	41.45	26.37	40.83	33.56	40.13	40.75	39.29	47.94
	2550	44.51	12.47	43.85	19.96	43.25	27.44	42.62	34.93	41.93	42.41	41.09	49.90
	2650	46.30	12.96	45.65	20.74	45.05	28.52	44.42	36.30	43.72	44.08	42.88	51.85
2750	48.10	13.45	47.45	21.52	46.84	29.60	46.22	37.67	45.52	45.74	44.68	53.81	

# EVV PERFORMANCE TABLE

NOTE : inlet flow rate Qs=m<sup>3</sup>/min

Model	RPM	Type EVV-200 performance											
		-1000mmAq		-2000mmAq		-3000mmAq		-4000mmAq		-5000mmAq		-6000mmAq	
		Qs	kw	Qs	kw	Qs	kw	Qs	kw	Qs	kw	Qs	kw
200	1470	33.59	9.71	32.57	15.53	31.63	21.35	30.65	27.17	29.56	33.00	28.25	38.82
	1560	35.77	10.30	34.75	16.48	33.81	22.66	32.83	28.84	31.74	35.02	30.43	41.20
	1650	37.96	10.89	36.93	17.43	35.99	23.97	35.02	30.50	33.93	37.04	32.62	43.57
	1750	40.38	11.55	39.36	18.49	38.42	25.42	37.44	32.35	36.35	39.28	35.04	46.22
	1850	42.81	12.21	41.79	19.54	40.84	26.87	39.87	34.20	38.78	41.53	37.47	48.86
	1950	45.23	12.87	44.21	20.60	43.27	28.32	42.29	36.05	41.20	43.77	39.89	51.50
	2050	47.66	13.53	46.64	21.66	45.69	29.78	44.72	37.90	43.63	46.02	42.32	54.14
	2150	50.08	14.19	49.06	22.71	48.12	31.23	47.14	39.74	46.05	48.26	44.74	56.78
	2250	52.51	14.85	51.49	23.77	50.54	32.68	49.57	41.59	48.48	50.51	47.17	59.42
	2350	54.93	15.52	53.91	24.82	52.97	34.13	51.99	43.44	50.90	52.75	49.59	62.06
	2450	57.36	16.18	56.34	25.88	55.40	35.59	54.42	45.29	53.33	55.00	52.02	64.70
	2550	59.79	16.84	58.76	26.94	57.82	37.04	56.85	47.14	55.75	57.24	54.44	67.34
2650	62.21	17.50	61.19	27.99	60.25	38.49	59.27	48.99	58.18	59.49	56.87	69.98	

Model	RPM	Type EVV-250 performance											
		-1000mmAq		-2000mmAq		-3000mmAq		-4000mmAq		-5000mmAq		-6000mmAq	
		Qs	kw	Qs	kw	Qs	kw	Qs	kw	Qs	kw	Qs	kw
250	1320	60.50	17.17	59.23	27.48	58.05	37.78	56.83	48.08	55.46	58.38	53.83	68.69
	1390	63.85	18.08	62.57	28.93	61.39	39.78	60.17	50.63	58.81	61.48	57.17	72.33
	1480	68.15	19.25	66.87	30.81	65.69	42.36	64.47	53.91	63.11	65.46	61.47	77.01
	1560	71.97	20.29	70.70	32.47	69.52	44.65	68.30	56.82	66.93	69.00	65.29	81.18
	1650	76.28	21.46	75.00	34.34	73.82	47.22	72.60	60.10	71.23	72.98	69.60	85.86
	1750	81.05	22.77	79.77	36.43	78.60	50.08	77.38	63.74	76.01	77.40	74.37	91.06
	1850	85.83	24.07	84.55	38.51	83.38	52.95	82.16	67.39	80.79	81.83	79.15	96.27
	1950	90.61	25.37	89.33	40.59	88.15	55.81	86.93	71.03	85.57	86.25	83.93	101.47

Model	RPM	Type EVV-300A performance											
		-1000mmAq		-2000mmAq		-3000mmAq		-4000mmAq		-5000mmAq		-6000mmAq	
		Qs	kw	Qs	kw	Qs	kw	Qs	kw	Qs	kw	Qs	kw
300A	1050	63.89	18.21	62.39	29.14	61.01	40.07	59.58	51.00	57.99	61.92	56.07	72.85
	1110	67.71	19.25	66.21	30.81	64.84	42.36	63.41	53.91	61.81	65.46	59.89	77.01
	1180	72.17	20.47	70.67	32.75	69.30	45.03	67.87	57.31	66.27	69.59	64.35	81.87
	1250	76.63	21.68	75.13	34.69	73.76	47.70	72.33	60.71	70.73	73.72	68.81	86.73
	1320	81.09	22.90	79.59	36.63	78.22	50.37	76.79	64.11	75.19	77.85	73.27	91.58
	1390	85.55	24.11	84.05	38.58	82.68	53.04	81.25	67.51	79.65	81.97	77.73	96.44
	1480	91.29	25.67	89.79	41.07	88.41	56.48	86.98	71.88	85.38	87.28	83.47	102.68
	1560	96.38	27.06	94.89	43.29	93.51	59.53	92.08	75.76	90.48	92.00	88.56	108.24
	1650	102.12	28.62	100.62	45.79	99.24	62.96	97.81	80.14	96.22	97.31	94.30	114.48
	1750	108.49	30.35	106.99	48.57	105.61	66.78	104.19	84.99	102.59	103.21	100.67	121.42
	1850	114.86	32.09	113.37	51.34	111.99	70.60	110.56	89.85	108.96	109.10	107.04	128.36

Model	RPM	Type EVV-300 performance											
		-1000mmAq		-2000mmAq		-3000mmAq		-4000mmAq		-5000mmAq		-6000mmAq	
		Qs	kw	Qs	kw	Qs	kw	Qs	kw	Qs	kw	Qs	kw
300	1050	90.98	25.88	88.96	41.40	87.10	56.93	85.16	72.46	83.00	87.98	80.41	103.51
	1110	96.42	27.36	94.39	43.77	92.53	60.18	90.60	76.60	88.44	93.01	85.84	109.42
	1180	102.75	29.08	100.73	46.53	98.86	63.98	96.93	81.43	94.77	98.88	92.18	116.32
	1250	109.09	30.81	107.07	49.29	105.20	67.77	103.27	86.26	101.11	104.74	98.52	123.23
	1320	115.43	32.53	113.40	52.05	111.54	71.57	109.61	91.09	107.45	110.61	104.86	130.13
	1390	121.76	34.26	119.74	54.81	117.88	75.36	115.95	95.92	113.79	116.47	111.19	137.03
	1480	129.91	36.47	127.89	58.36	126.02	80.24	124.09	102.13	121.93	124.01	119.34	145.90
	1560	137.16	38.45	135.13	61.51	133.27	84.58	131.34	107.65	129.18	130.72	126.58	153.79
	1650	145.30	40.66	143.28	65.06	141.42	89.46	139.48	113.86	137.32	138.26	134.73	162.66
	1750	154.36	43.13	152.33	69.01	150.47	94.88	148.54	120.76	146.38	146.64	143.78	172.52
	1850	163.41	45.59	161.39	72.95	159.52	100.31	157.59	127.66	155.43	155.02	152.84	182.37

## DIMENSION OF ACCESSORIES: EV SUCTION SILENCER

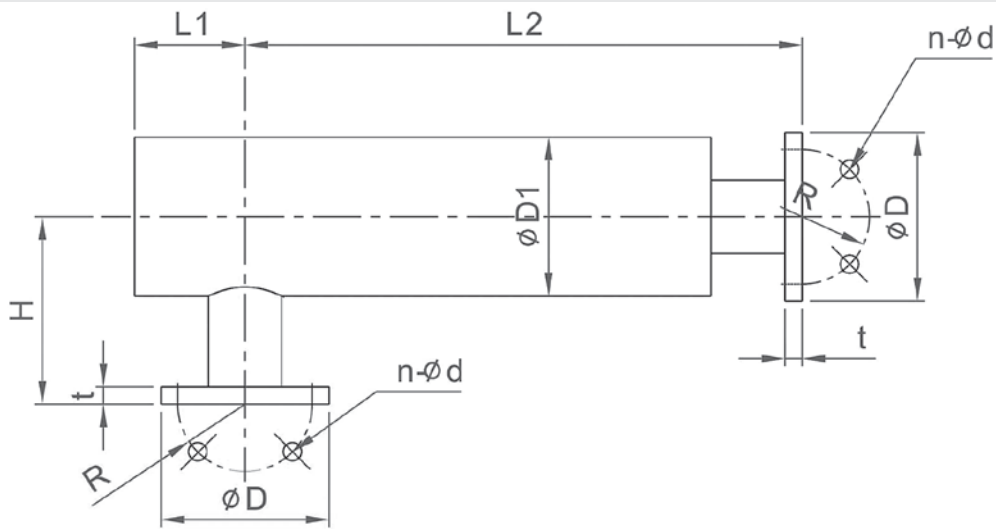

Unit: mm

Model	$\phi D$	t	n- $\phi d$	R	$\phi D1$	$\phi D2$	H	L1	L2
EV-65	185	18	4- $\phi 18$	72.5	165.2	140	160	90	581
EV-80	200	18	8- $\phi 18$	80	216.3	190	235	100	667
EV-100	220	18	8- $\phi 18$	90	240	190	230	175	792
EV-125	250	20	8- $\phi 18$	105	280	245	290	165	885
EV-150A/150	285	22	8- $\phi 22$	120	300	270	295	180	1036
EV-200	340	24	8- $\phi 22$	147.5	400	350	365	200	1204
EV-250	395	24	12- $\phi 22$	175	420	390	430	250	1423
EV-300A/300	445	24	16- $\phi 22$	200	500	450	450	250	1585

## DIMENSION OF ACCESSORIES: EV DISCHARGE SILENCER

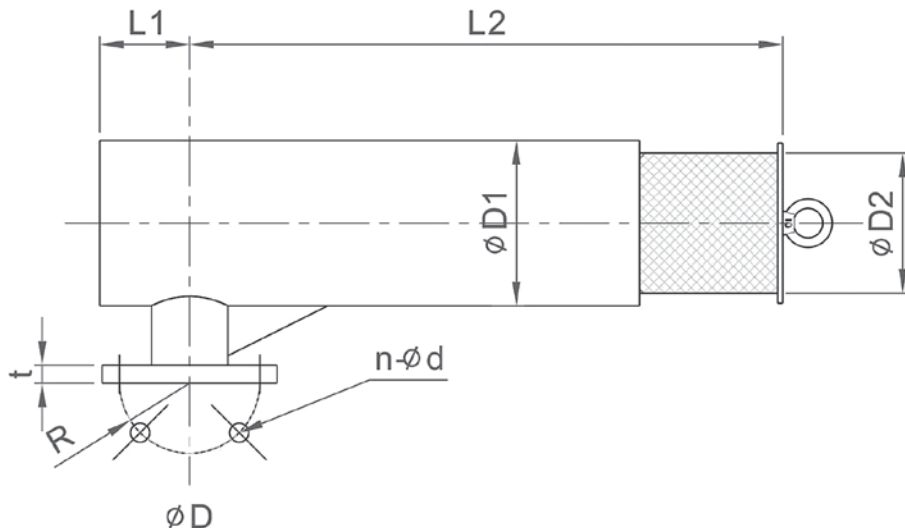

Unit: mm

Model	$\phi D$	t	n- $\phi d$	R	$\phi D1$	H	L1	L2
EV-65	185	18	4- $\phi 18$	72.5	165.2	195	115	580
EV-80	200	18	8- $\phi 18$	80	216.3	235	100	594
EV-100	220	18	8- $\phi 18$	90	240	230	175	720
EV-125	250	20	8- $\phi 18$	105	280	290	205	950
EV-150A/150	285	22	8- $\phi 22$	120	300	305	200	1005
EV-200	340	22	12- $\phi 22$	147.5	420	420	200	1170
EV-250	395	24	12- $\phi 22$	175	420	430	250	1255
EV-300A/300	445	24	16- $\phi 22$	200	500	450	250	1420

## DIMENSION OF ACCESSORIES: EVV VACUUM FILTER TANK

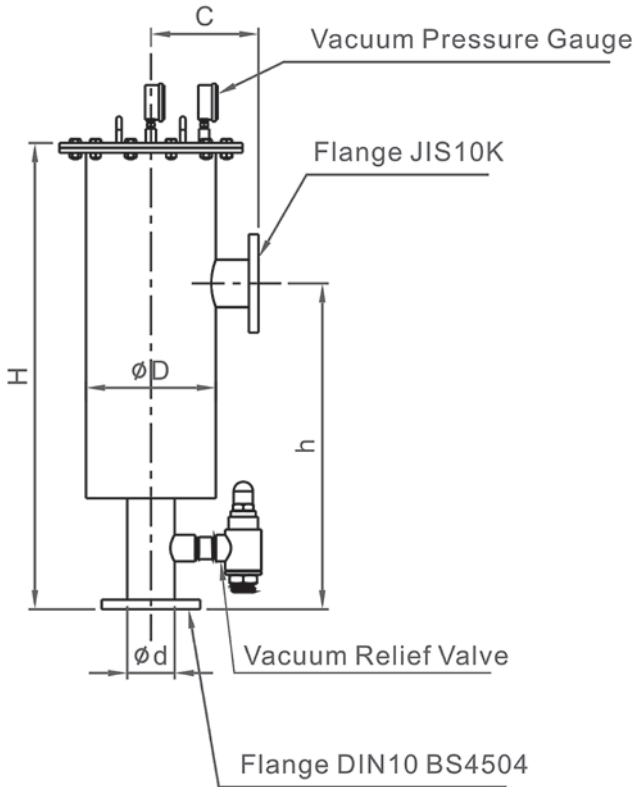

Model	H	h	C	øD	ød	Flange
EVV-65/80	657	459	202	244	76.3	JIS 2½" 10K
EVV-100/125	877	613	202	244	89.1	JIS 3" 10K
EVV-150	877	613	202	244	114.3	JIS 4" 10K
EVV-200	805	610	260	360	139.8	JIS 5" 10K
EVV-250A/150	925	690	260	360	165.2	JIS 6" 10K
EVV-300	1075	770	310	470	216.3	JIS 8" 10K
EVV-350	1200	900	310	470	267.4	JIS 10" 10K
EVV-400A/300	1350	1000	405	600	318	JIS 12" 10K

Unit: mm

## DIMENSION OF ACCESSORIES: VACUUM RELIEF VALVE

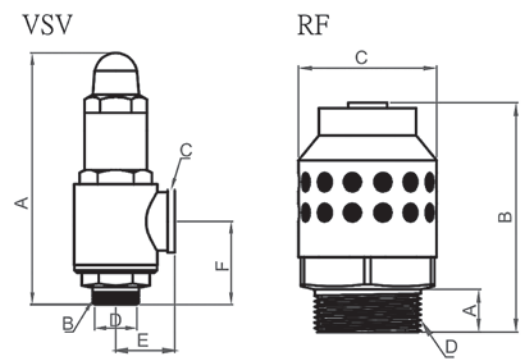

TYPE	A	B	C	D	E	F	Fitting Model
VSV 1¼"	210	1¼"	1¼"	1¼"	51	70	EVV-65/80
VSV 2"	255	2"	2"	2"	67	89	EVV-100/125/150A/150/200/250

TYPE	A	B	C	D	Fitting Model
RF 4"					

Unit: mm

## DIMENSION OF ACCESSORIES: RELIEF VALVE

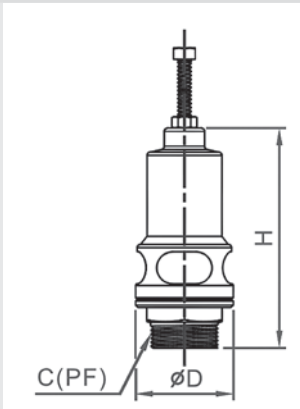

TYPE	H	øD	C	Fitting Model
PP 1¼"	182	72	1¼"	EV-65/80
PP 2"	192	85	2"	EV-100/125/150A/150
PP 3"				

Unit: mm

## DIMENSION OF ACCESSORIES: CHECK VALVE

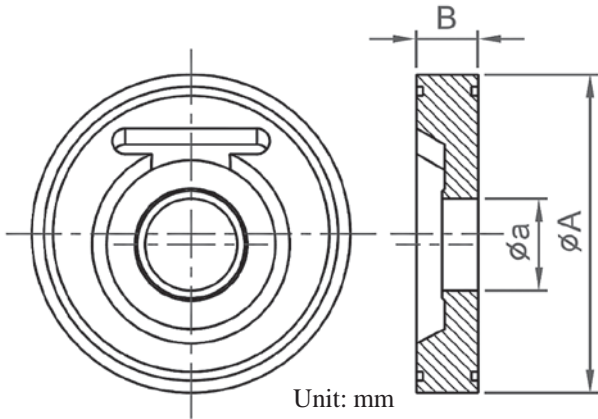

Model	$\phi A$	$\phi a$	B
EV-65	124.5	36	24
EV-80	133	45	24
EV-100	157	65	22
EV-125	187	88	24
EV-150A/150	220	110	26
EV-200	269	138	27
EV-250	330	186	28
EV-300A/300	380	212	32

## DIMENSION OF ACCESSORIES: EV SERILIENT CONNECT

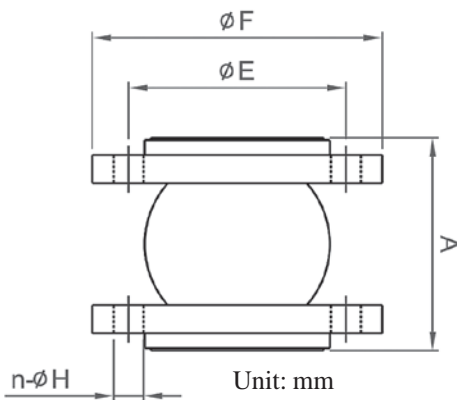

Model	A	$\phi E$	$\phi F$	n- $\phi H$
EV-65	115	140	175	4- $\phi 19$
EV-80	135	150	185	8- $\phi 19$
EV-100	136	175	210	8- $\phi 19$
EV-125	174	210	250	8- $\phi 23$
EV-150A/150	185	240	280	8- $\phi 23$
EV-200	205	290	330	12- $\phi 23$
EV-250	245	355	400	12- $\phi 25$
EV-300A/300	260	400	445	16- $\phi 25$

## DIMENSION OF ACCESSORIES: EV FILTER

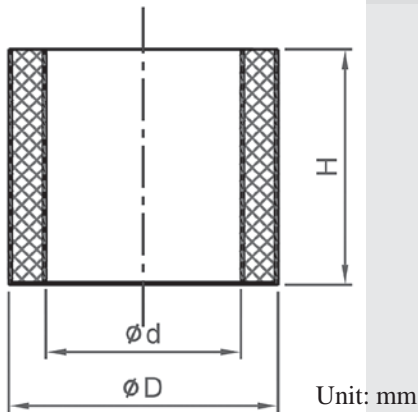

Model	$\phi D$	$\phi d$	H
EV-65	150	85	85
EV-80/100	200	125	165
EV-125	260	170	180
EV-150A/150	290	210	190
EV-200	320	265	225
EV-250	340	281	225
EV-300A/300			

## DIMENSION OF ACCESSORIES: VIBRATION ISOLATOR

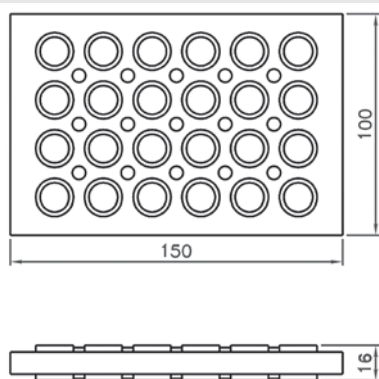

Fitting Model : all EV type