



Made In Taiwan

Sunwins Linear Air Pump (HB/AL-100, 120, 150, 200)



AL-100 ~ AL-250

Nominal Performance

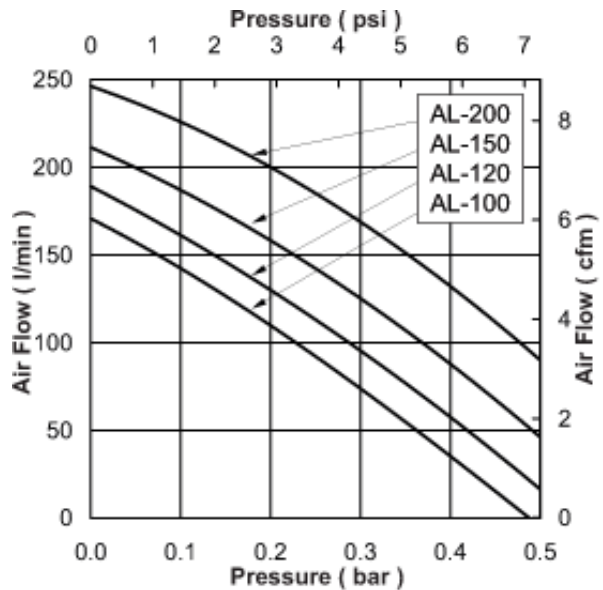

Specification

Model	HB/AL-100	HB/AL-120	HB/AL-150	HB/AL-200
Voltage (V)	AC 240V			
Frequency (Hz)	50			
Rated Pressure (mbar, psi)	180, 2.6			200, 2.90
Rated Performance (lpm, cfm)	113, 4	130, 4.6	160, 5.6	200, 7.0
Rated Input Power (W)	120	124	160	261
Sound Level (dB)	41	42	44	45
Discharge O.D. (mm, in)	18, 5/8			
Weight (kg, lb)	8.3, 18.2	8.3, 18.2	10.1, 22.3	10.1, 22.3

Specifications and performance data are subject to change without notice
Actual product may slightly differ than pictures shown

Dimension

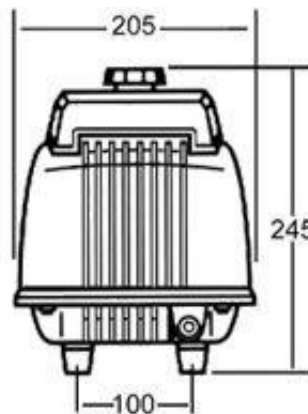
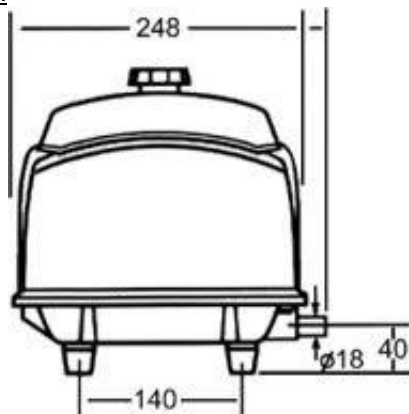

Unit (mm)

Application



Home

Medical

Life

Industry

Home

Medical

Life

Industry