

Side Channel Blower

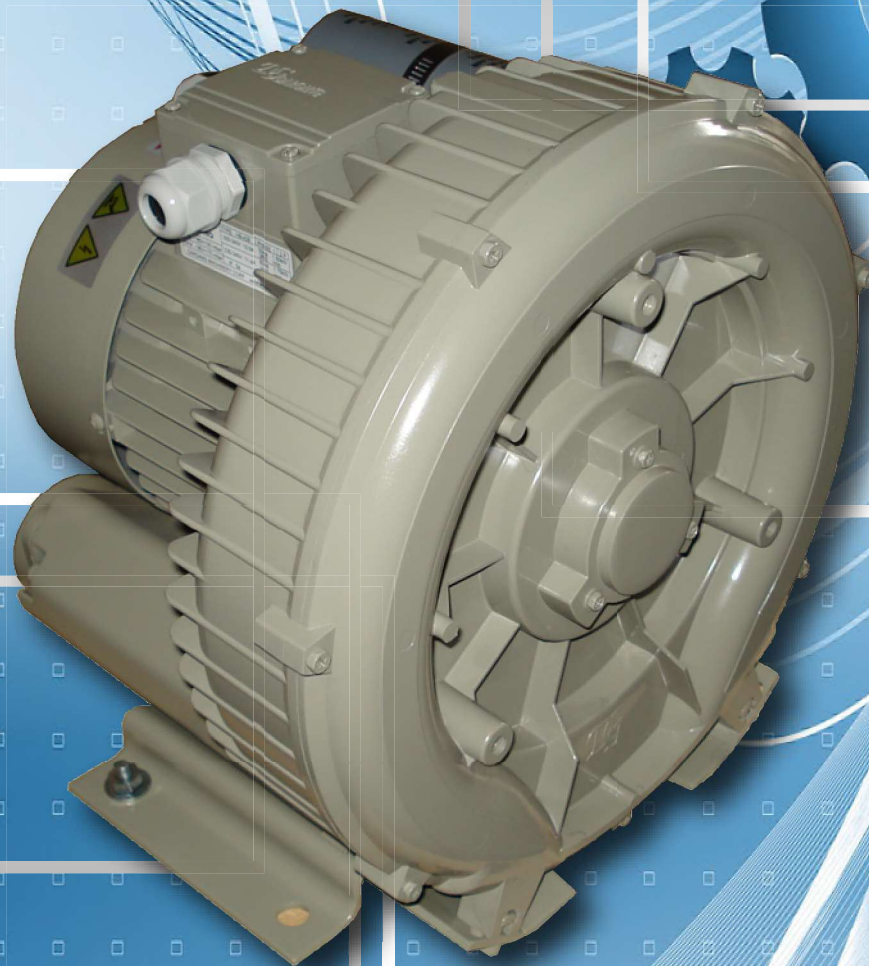

DG DARGANG

APEX DARGANG MACHINERY CORPORATION

Side Channel Blower Construction

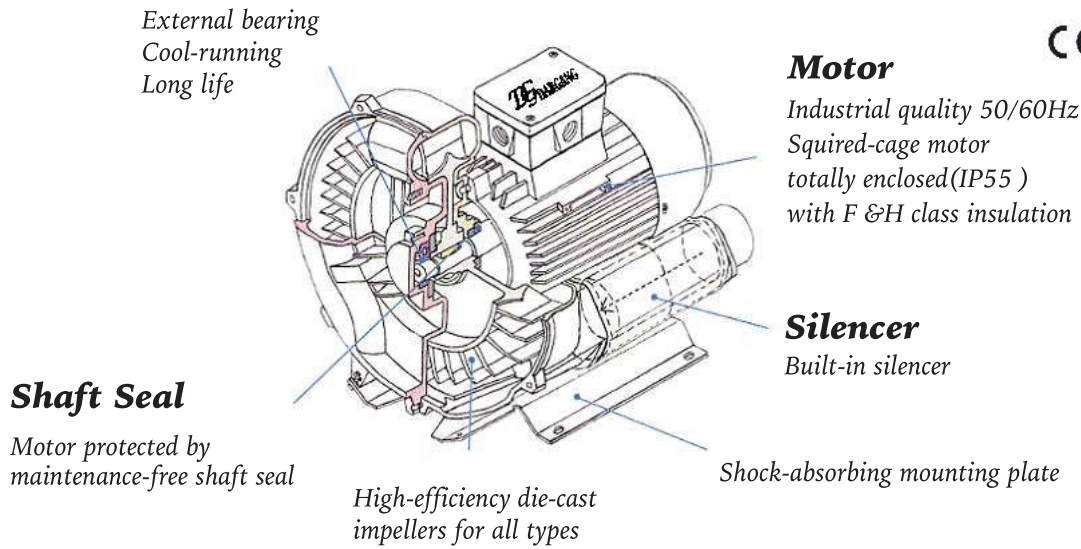

Side Channel Blower Specific

Easy to install

The blower is a complete unit ready for immediate installation either as a vacuum pump or as a compressor. The unit can be mounted in any position, horizontally or vertically.

Rugged, the cast for the impeller and the motor are individual to be made by aluminum. The blower has the highly-developed design which results in a pump construction with one moving part, a feature ensuring maximum operating reliability. Maintenance free!

No oily odors

The impeller rotates with absolutely no contact between it and the housing. This means no lubrication is required, guaranteeing 100% oil-free operation.

Low Noise and Vibration

The use of direct-driving low-noise motors and integral silencers ensure a low noise level. Dynamic balancing minimizes vibration.

High Efficiency

Under serious QC control, the parts used in DG blower are of top quality. All blowers are made by professional technicians.



Single Phase AC IP55 50Hz



Model	Curve No.	Frequency (Hz)	Output (kW)	Voltage (V)	Current (A)	Vacuum / Compressor (mbar)	Max Airflow (m ³ /min)	Noise (dB)A	Weight (Kg)
HB-129-S	D1	50	0.18	200-240	1.25	50	1.0	52	6.5
HB-229-S	D2	50	0.4	200-240	2.90	110	1.5	58	11.5
HB-229W-S	D3	50	0.4	200-240	2.90	110	1.5	58	12
HB-329-S	D4	50	0.75	200-240	5.80	140	2.6	63	16
HB-329W-S	D5	50	0.75	200-240	5.80	140	2.5	63	16.5
HB-429-S	D8	50	1.5	200-240	10.0	180	3.7	70	26
HB-429W-S	D9	50	1.5	200-240	10.0	180	3.7	70	26.5
HB-2308-S	D10	50	0.75	200-240	4.50	180	1.6	60	17.5
HB-3315-S	D11	50	1.5	200-240	10.0	240	2.6	66	28.5



50Hz / Single Phase Curve



Vacuum

■ 50Hz (Single Stage)
 ■ 50Hz (Two Stage)

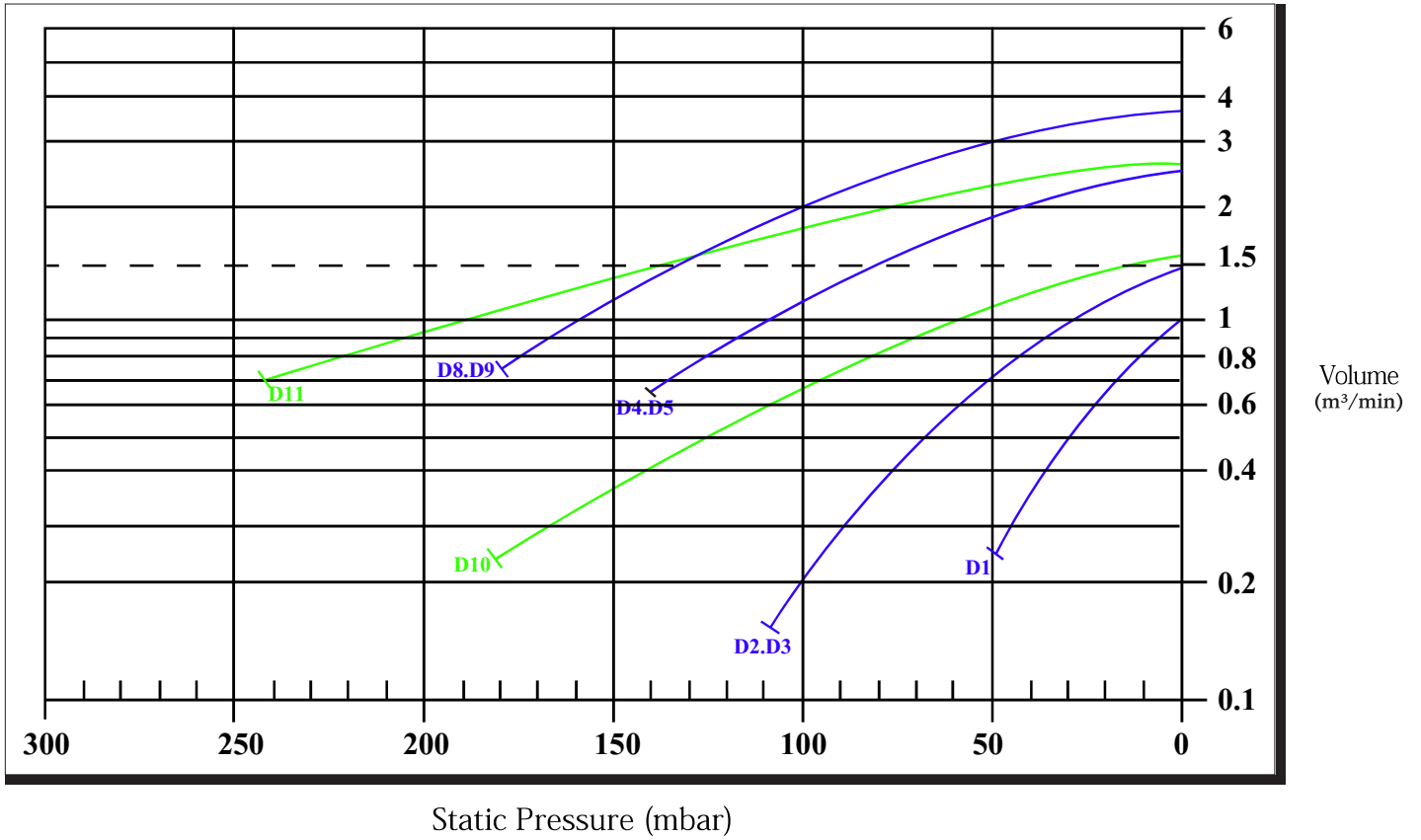

Compressor

■ 50Hz (Single Stage)
 ■ 50Hz (Two Stage)

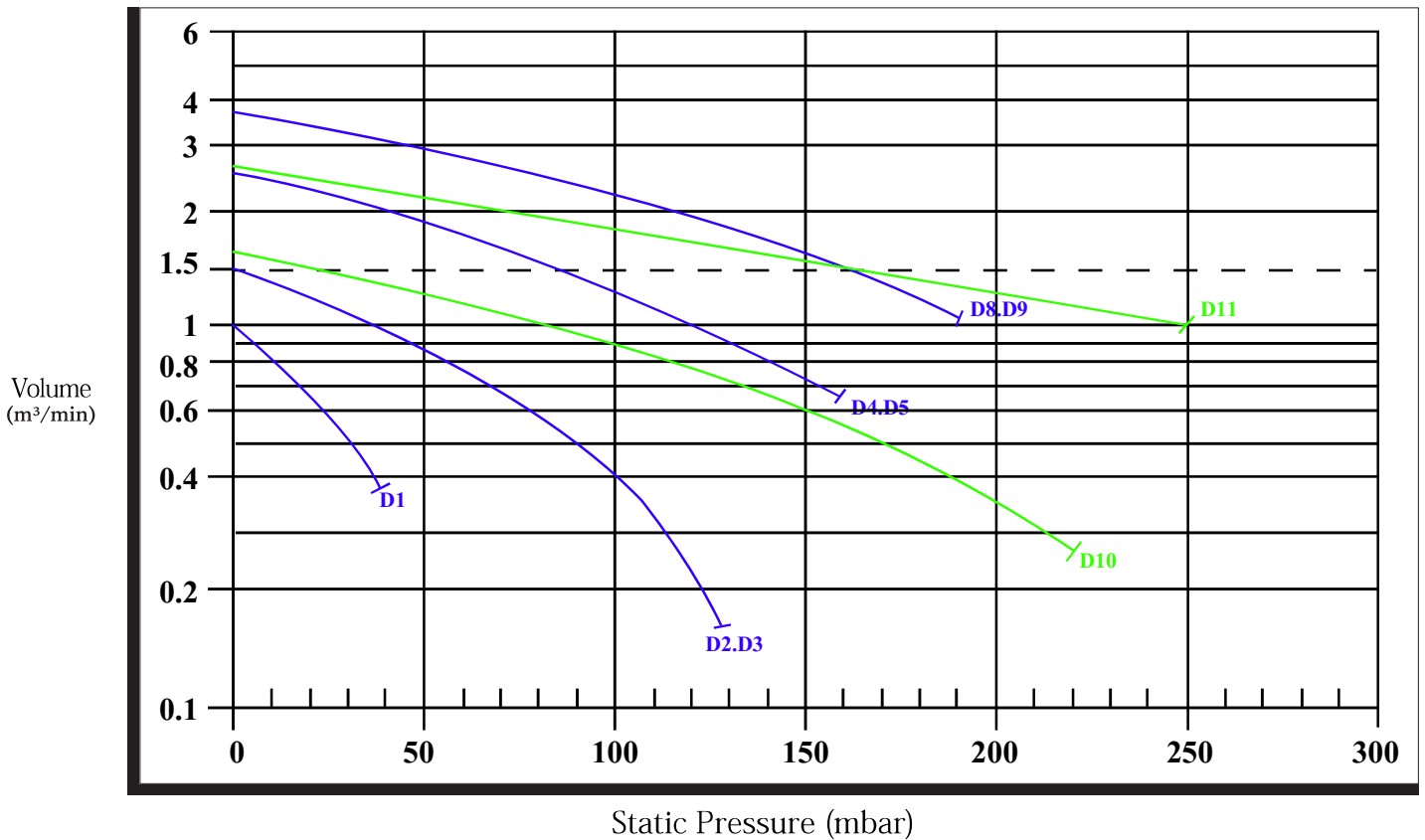

Three Phase AC IP55 50Hz

Model	Curve No.	Frequency (Hz)	Output (kW)	Voltage (V)	Current (A)	Static pressure Vacuum / Compressor (mbar)	Max Airflow (m ³ /min)	Noise (dB)A	Weight (Kg)
HB-129	D12	50	0.18	200-240 △ /345-415Y	1.20△/0.69Y	50/60	1	52	6.5
HB-229	D13	50	0.4	200-240 △ /345-415Y	2.20△/1.30Y	110/130	1.5	58	10.5
HB-329	D15	50	0.75	200-240 △ /345-415Y	3.70△/2.14Y	140/140	2.6	63	14
HB-339	D19	50	1.3	200-240 △ /345-415Y	4.60△/2.65Y	175/200	2.6	63	16
HB-429	D22	50	1.75	200-240 △ /345-415Y	6.70△/3.90Y	210/220	3.7	70	23
HB-439	D25	50	2.2	200-240 △ /345-415Y	7.80△/4.50Y	220/270	3.7	70	26
HB-529	D26	50	2.2	200-240 △ /345-415Y	9.70△/5.60Y	220/210	5.5	72	32
HB-629	D29	50	3.4	200-240 △ /345-415Y	12.5△/7.20Y	255/270	5.5	72	34
HB-639	D31	50	4	200-240 △ /345-415Y	14.3△/8.20Y	270/320	5.5	72	37
HB-729	D32	50	5.5	200-240 △ /345-415Y	25.3△/14.6Y	270/290	9.5	74	77
HB-829	D33	50	7.5	200-240 △ /345-415Y	31.5△/18.2Y	295/390	9.5	74	88
HB-919	D34	50	9	200-240 △ /345-415Y	36.0△/20.8Y	200/190	18.9	76	100
HB-929	D35	50	13	200-240 △ /345-415Y	46.8△/27.0Y	290/270	18.9	76	112
HB-939	D36	50	20	200-240 △ /345-415Y	66.7△/38.6Y	350/440	18.9	76	159
HB-2308	D37	50	0.75	200-240 △ /345-415Y	3.70△/2.14Y	200/240	1.6	60	17
HB-3319	D38	50	1.75	200-240 △ /345-415Y	6.70△/3.90Y	275/300	2.6	66	25
HB-3326	D39	50	2.2	200-240 △ /345-415Y	7.80△/4.50Y	320/390	2.6	66	28
HB-4337	D40	50	3.4	200-240 △ /345-415Y	12.5△/7.20Y	345/410	3.7	74	40
HB-4346	D41	50	4	200-240 △ /345-415Y	14.3△/8.20Y	355/460	3.7	74	43
HB-6346	D42	50	4	200-240 △ /345-415Y	14.3△/8.20Y	350/350	5.5	75	55
HB-6355	D43	50	5.5	200-240 △ /345-415Y	21.6△/12.5Y	410/500	5.5	75	72
HB-6375	D44	50	7.5	200-240 △ /345-415Y	31.5△/18.2Y	420/580	5.5	75	82
HB-6455	D45	50	5.5	200-240 △ /345-415Y	25.3△/14.6Y	200/220	7.9	75	72
HB-6475	D46	50	7.5	200-240 △ /345-415Y	31.5△/18.2Y	240/275	7.9	75	82
HB-8310	D47	50	7.5	200-240 △ /345-415Y	31.5△/18.2Y	350/350	9.5	76	112
HB-8315	D48	50	13	200-240 △ /345-415Y	46.8△/27.0Y	430/600	9.5	76	142
HB-8320	D49	50	20	200-240 △ /345-415Y	66.7△/38.6Y	450/700	9.6	76	160
HB-8410	D50	50	7.5	200-240 △ /345-415Y	31.5△/18.2Y	180/145	14.2	76	110
HB-8415	D51	50	13	200-240 △ /345-415Y	46.8△/27.0Y	250/250	14.2	76	140

Remark:

1. Information above is for reference, product only when different.
2. We reserve the right to change the design without notice.
3. Should you require any further information or assistance, please do not hesitate to contact us or distributors.

50Hz / Three Phase Curve



Vacuum

50Hz (Single Stage)

50Hz (Two Stage)

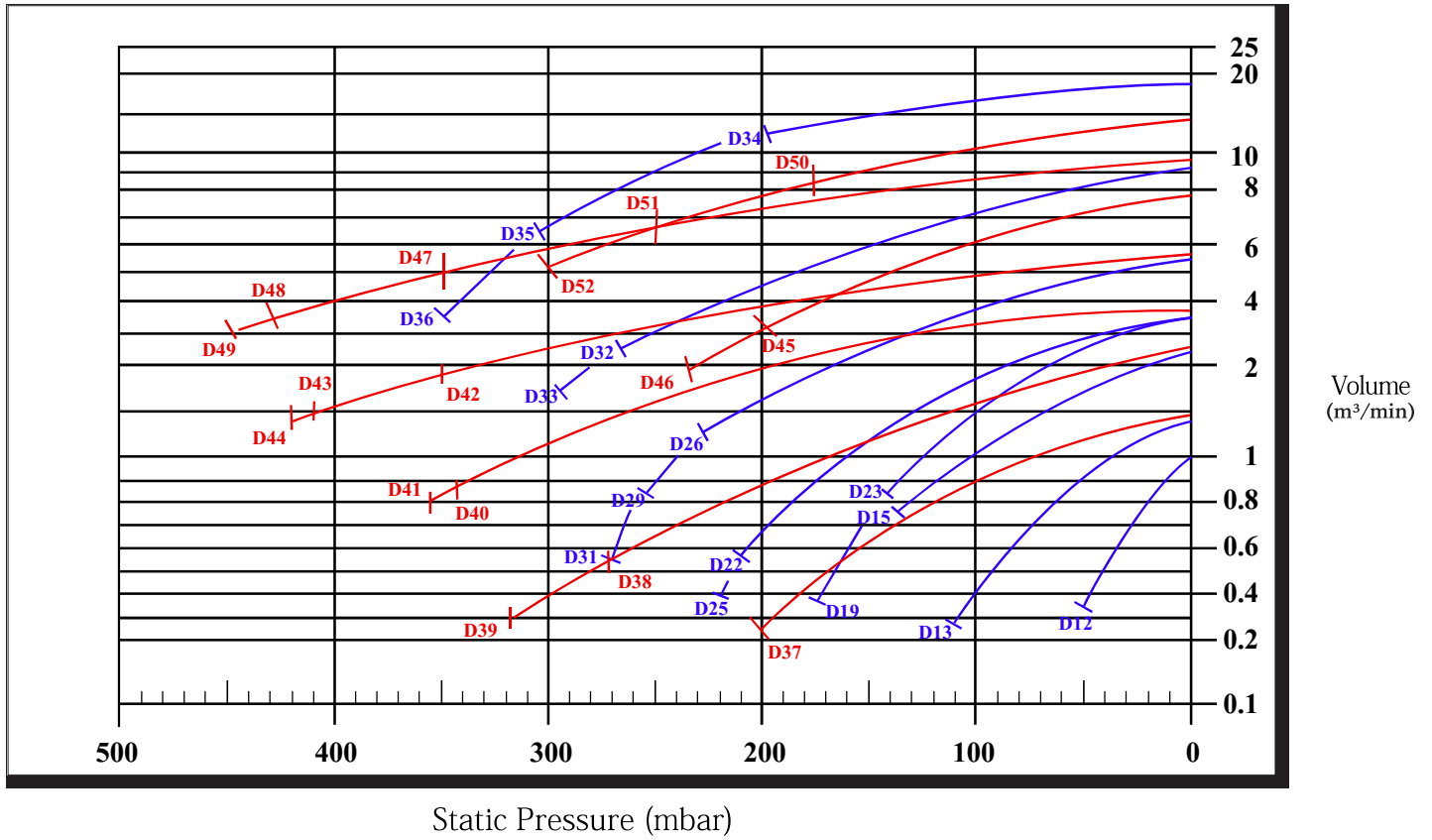

Compressor

50Hz (Single Stage)

50Hz (Two Stage)

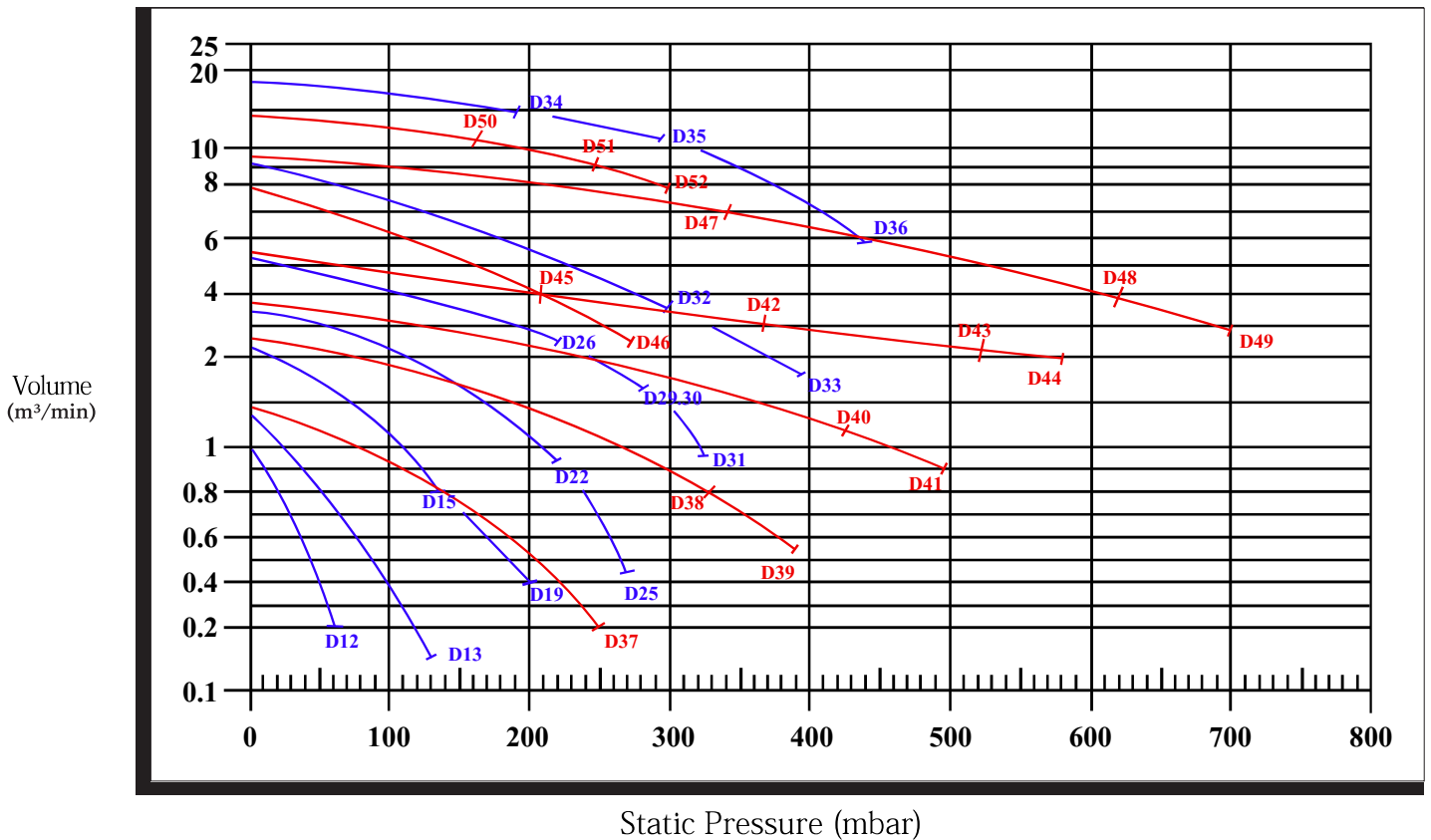

鼓風機之尺寸表(Dimensions)



HB129S
HB129

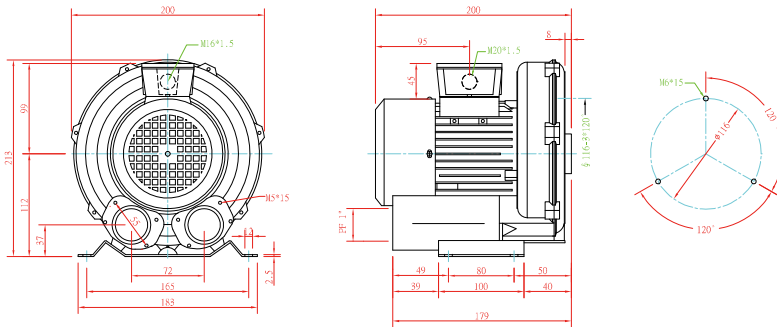

HB229S
HB229

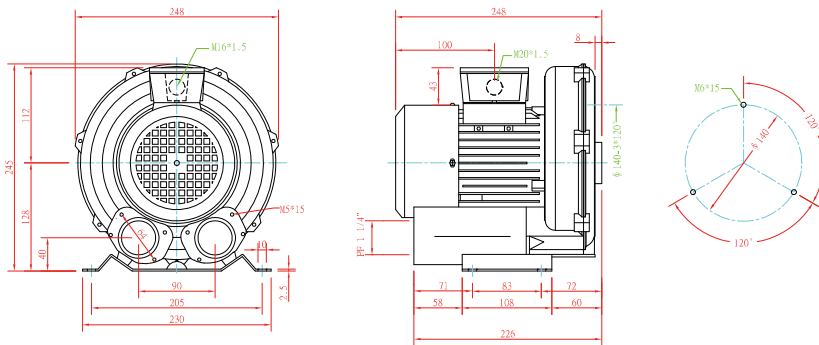

HB329S
HB329

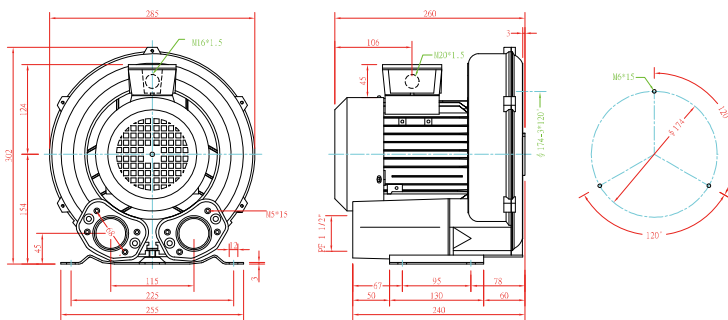

HB429S
HB429

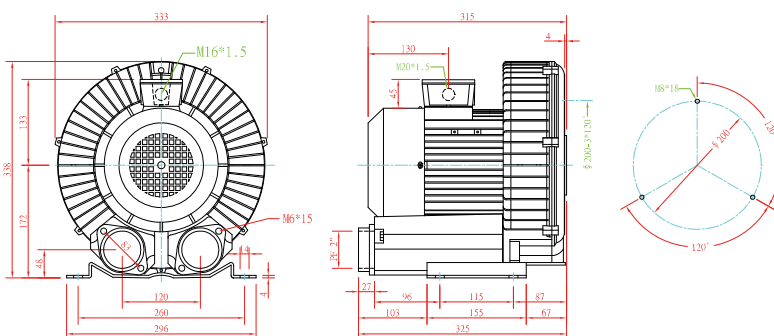

鼓風機之尺寸表(Dimensions)

HB529
HB629
HB639

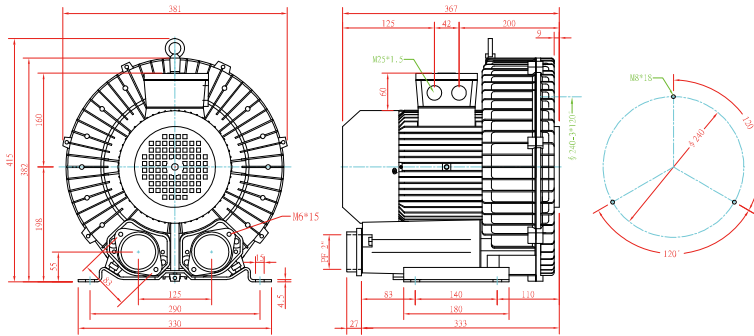

HB729
HB829

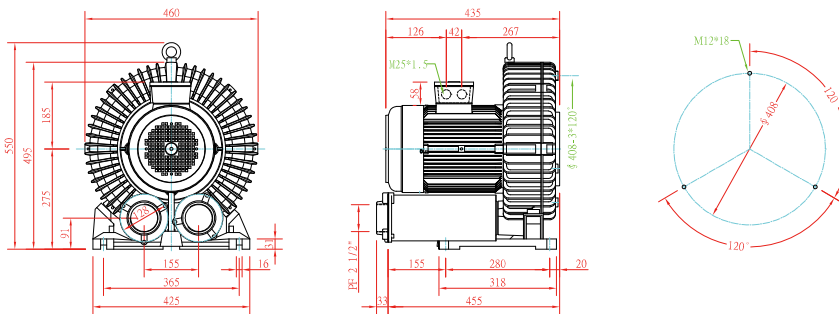

HB919
HB929
HB939

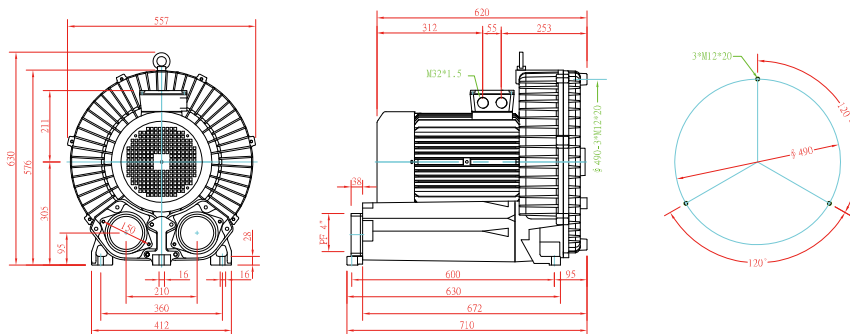

HB2308S
HB2308

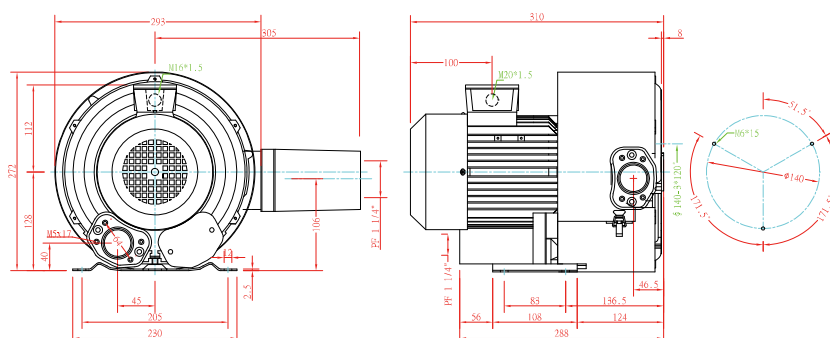

鼓風機之尺寸表(Dimensions)

HB3315-S

HB3319

HB3326

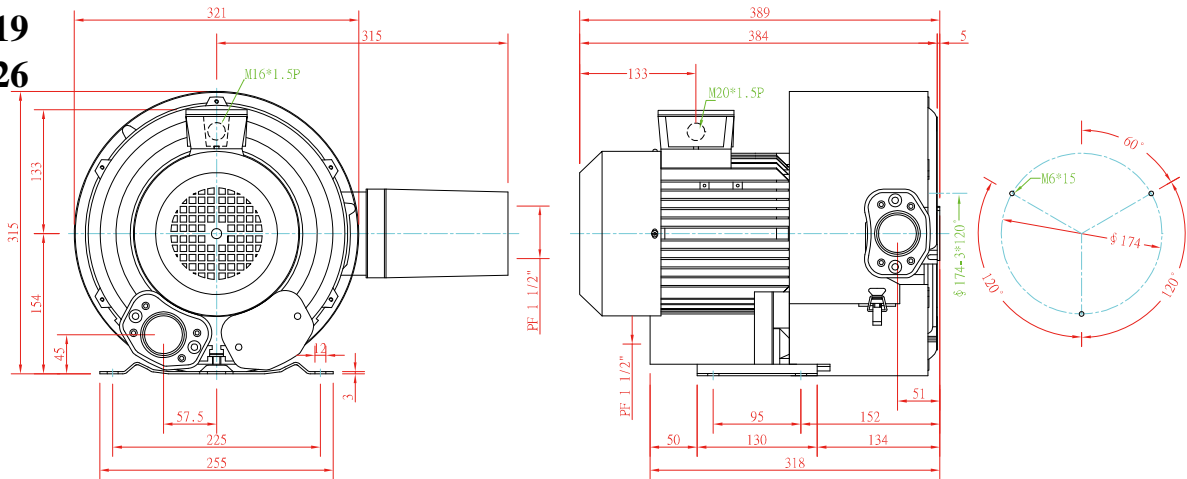

HB4337

HB4346

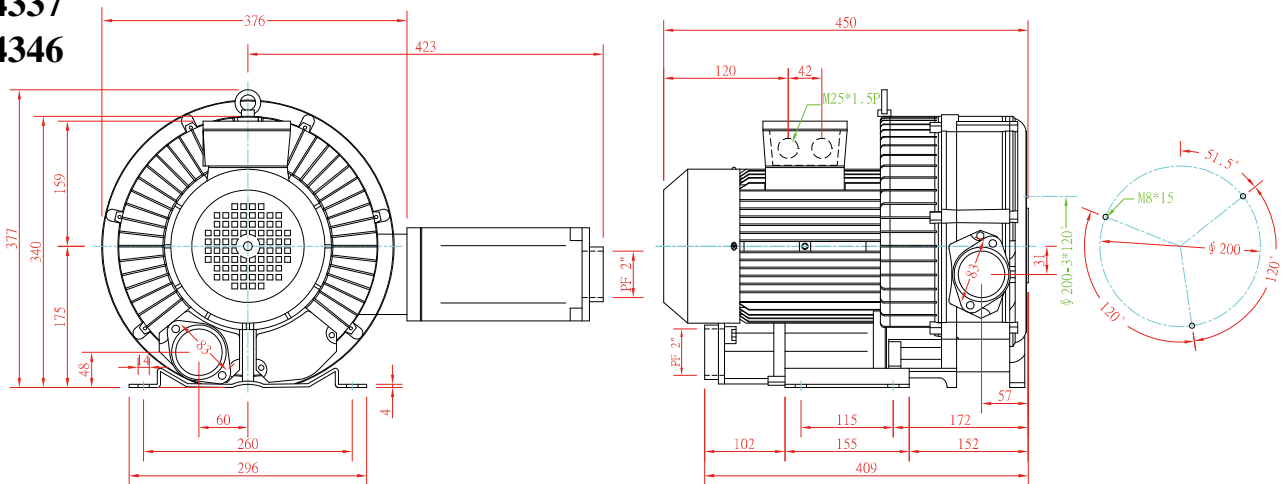

HB6346

HB6355

HB6375

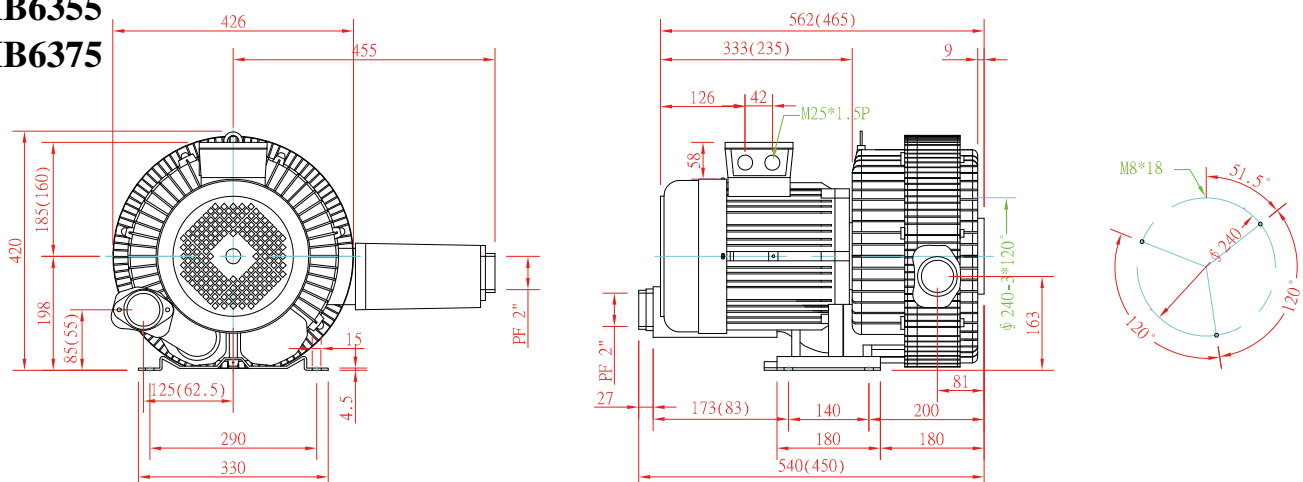

鼓風機之尺寸表(Dimensions)

HB6455
HB6475

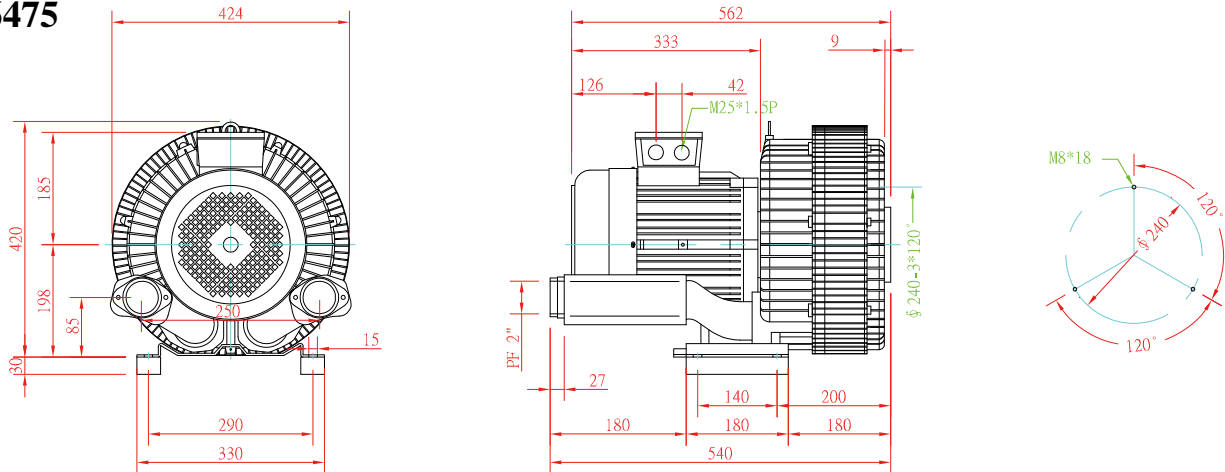

HB8310
HB8315
HB8320

()For HB-830-1*

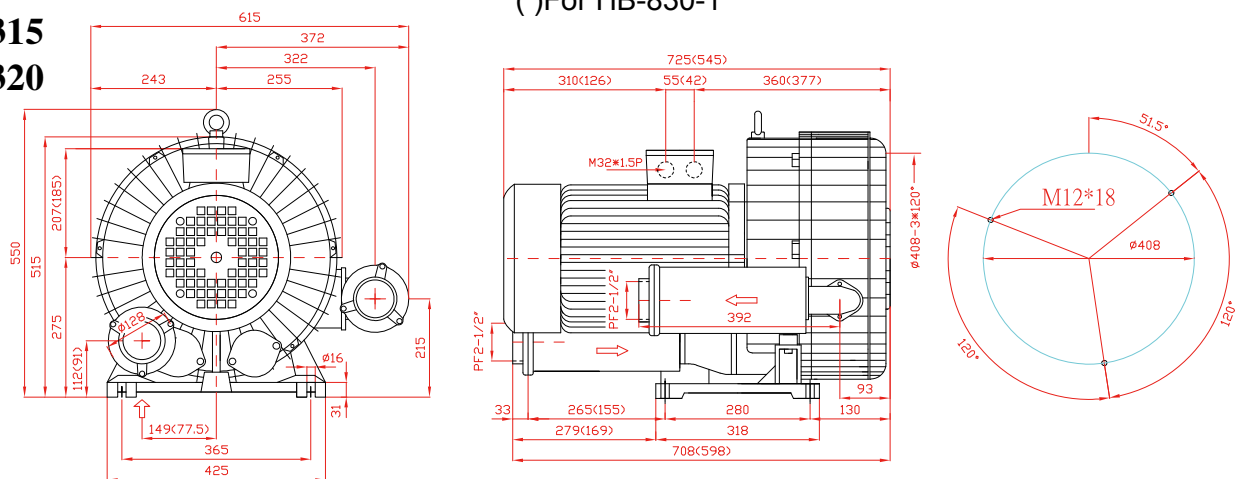

HB8410
HB8415
HB8420

()For HB-840-1*

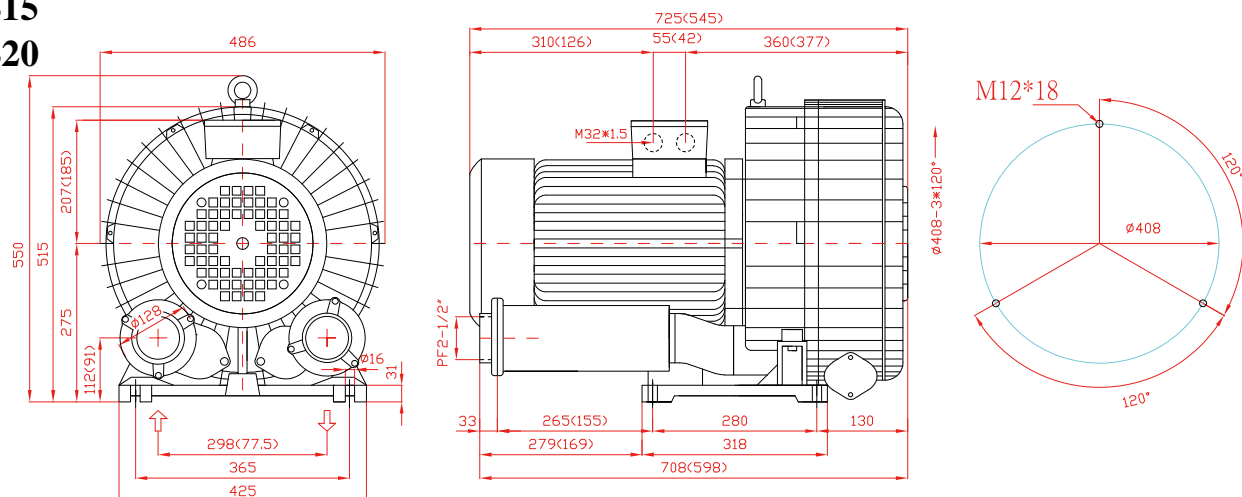

鼓風機之零件圖(Parts Illustration)

單段式(Single)

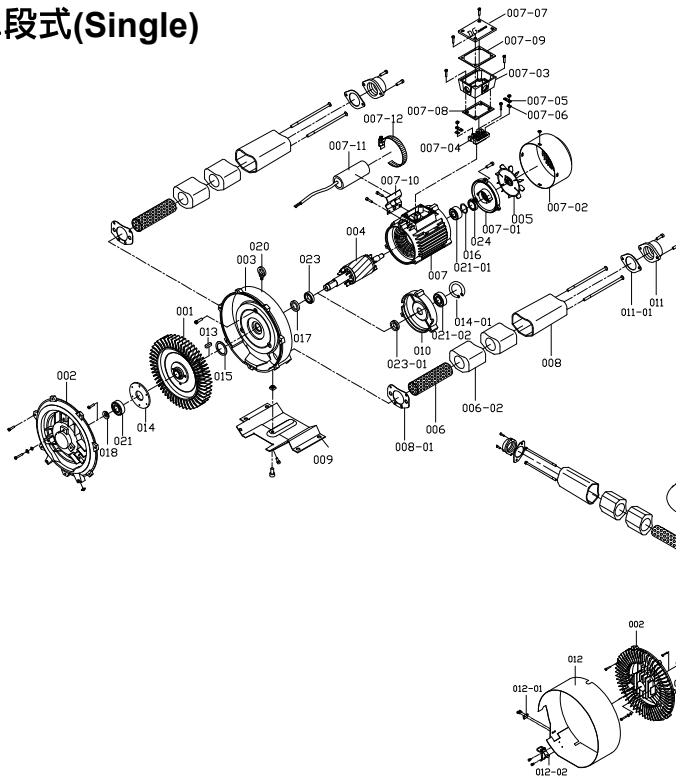

雙段式(Double stage)

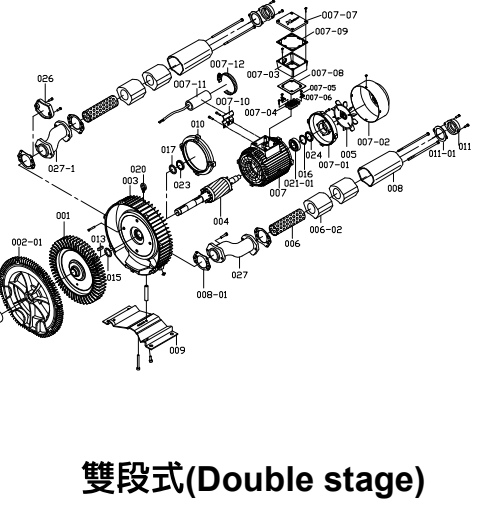

編號 ITEM	零件名稱 PARTS NAME	編號 ITEM	零件名稱 PARTS NAME	編號 ITEM	零件名稱 PARTS NAME
001	風葉 Impeller	007-08	配線盒墊片 Terminal box washer	015	風葉墊片 Washer
002	風蓋 Compressor cover	007-09	配線盒蓋墊片 Terminal cover washer	016	波浪墊片 Ware washer
002-01	中風蓋 Middle compressor cover	007-10	電容器固定片 Capacitor washer	017	羊毛氈 Cotton seal
003	風桶 Compressor housing	007-11	電容器 Capacitor	018	前軸承墊片 Washer
003-01	中風桶 Middle compressor housing	007-12	管束 Steel clip	020	吊環 Bronze ring
004	轉子 Rotor	008	腳管 Silencer housing	021	前軸承 Front bearing
005	散熱葉 Fan	008-01	腳管墊片 Silencer washer	021-01	後軸承 Rear bearing
006	消音鐵網 Silencer mesh pipe	009	腳座 Mounting plate	021-02	前軸承 Front bearing
006-02	消音海綿 Silencer sponge	010	馬達中蓋 Middle motor cover	023	前軸封 Front oil seal
007	馬達 Motor	011	牙口 Inlet/outlet	023-01	軸封 VA-seal
007-01	馬達後蓋 Motor cover	011-01	牙口墊片 Inlet/outlet washer	024	後軸封 Rear oil seal
007-02	散熱鐵蓋 Fan cover	012	外觀鐵片 Protection steel skin	025	腳管固定座 Silencer socket
007-03	配線盒 Terminal box	012-01	上箱扣 Buckle (up)	026	出口封蓋 Outlet cover
007-04	配線端子 Wire socket	012-02	下箱扣 Buckle (down)	026-01	封蓋 Cover
007-05	銅片 Wire connection slice	013	鍵 Rotor pin	027	彎管 Extend pipe
007-06	壓板 Fixed slice	014	前軸承固定片 Bearing washer	027-1	彎管 Extend pipe
007-07	配線盒蓋 Terminal cover	014-01	軸承C型扣環 Bearing washer	028	90° 彎管 90° extend pipe

* 訂購時請告知型號+零件編號 (例如:DG-600-26+002)

* Please notify model+parts item when you purchase.

* 本公司保有設計變更之權利，恕不另行通知。

* We reserve the right to change the design without notice.

鼓風機配件表(Accessories)

釋壓閥 / Pressure Relief Valve

型號 Type	口徑/PF Port	L (mm)	規格 Dimension
RV-01	1 1/4"	142	0~3000mmAq
RV-02	1 1/4"	142	0~6000mmAq

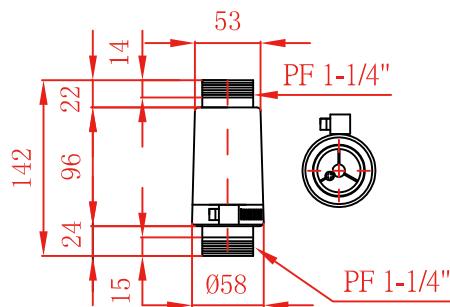

三通管 / Tee Pipe (mm)

型號 Type	適用機型 Application
TP-01	HB-200,230,300,330 系列(Serial)
TP-02	HB-400,430,600,630,640 系列(Serial)

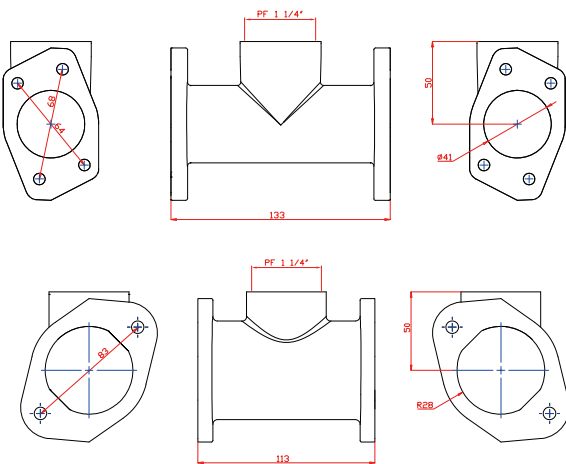

TP-01



TP-02

MF型過濾器 / MF Type Suction Filter

符號 Symbol 型號 Type	口徑 PT	D (mm)	L (mm)	H (mm)	B (mm)	過濾精度(目) Filtration mesh	重量(kg) Weight
MF-08	1"	58	170	155	42	100	0.20
MF-10	1 1/4"	71	186	170	54	100	0.35
MF-12	1 1/2"	85	196	182	65	100	0.49
MF-16	2"	103	215	202	75	100	0.65
MF-20	2 1/2"	148	274	252	97	100	1.20
MF-32	4"	208	380	357	142	100	2.45

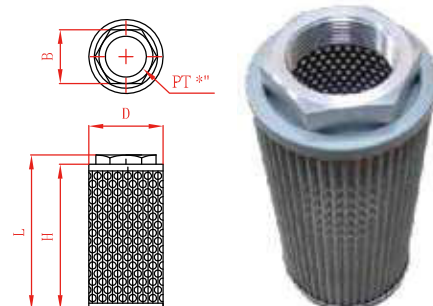

鼓風機配件表(Accessories)

消音器

型號 Type	符號 Symbol	A	B (mm)	C (mm)
SI-01	PF 1 1/4"		83	180
SI-02	PF 1 1/2"		98	180
SI-03	PF 2"		117	266
SI-04	PF 2 1/2"		145	325

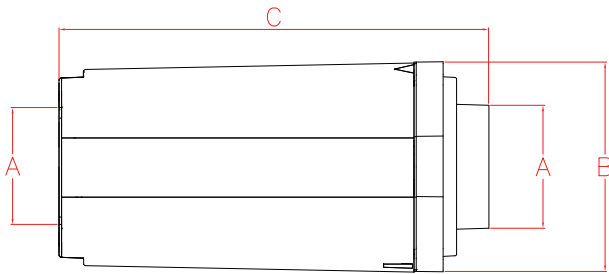

牙口/Threaded Flange[mm]

型號 Type	符號 Symbol	A	B	C	D	E	F
2-011	PF 1 1/4"	7	22	64	79	6	
3-011	PF 1 1/2"	7	24	68	86	6	
6-011	PF 2"	7	18	83	100	7	
8-011	PF 2 1/2"	15	16	Ø128	144	7	
9-011	PF 4"	8	22	150	170	9	

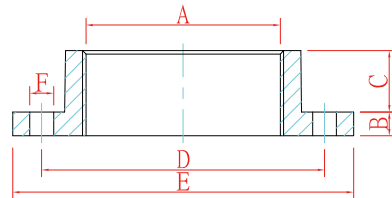

防震腳墊供垂直或水平安裝

Footprint dimensions for vertical/horizontal mounting[mm]

型號 Type	D	H	G	L
MFB2520	25	20	M6	12
MFB3025	30	25	M8	15
MFB7540	75	40	M12	20
MFB7545	75	45	M12	37

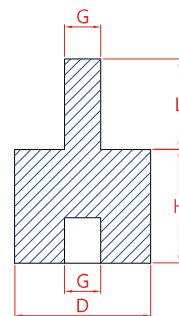

附註 / Remark : 若需要其他配件, 請與本公司或經銷商連絡
If you need other accessories, please contact us or distributors.

單位換算表(Unit Conversion Table)

壓力 / Pressure								
mmAq	kg/cm ²	mmHg	inHg	PSIG (lb/in ²)	%真空	Troo	K.pa	mbar
0	0.	0	0.	0.	0.	760	0.	0
500	0.05	37	1.45	0.71	4.8	723	4.90	49
1000	0.1	74	2.89	1.42	9.7	686	9.81	98
1500	0.15	110	4.34	2.13	14.5	650	14.71	147
2000	0.2	147	5.79	2.84	19.3	613	19.61	196
3000	0.3	221	8.68	4.26	29.0	539	29.42	294
5000	0.5	368	14.47	7.10	48.4	392	49.03	490
10000	1.0	735	28.95	14.20	96.7	25	98.07	981
10336	1.0336	760	29.92	14.68	100.0	0	101.36	1014

同/same

mmH₂O, mmW.g, mmW.C, mmW.S, kg/m³kp, kg. f/m³, KP/m³

風量 / Air Flow			
m ³ /min	l/min	CFM (ft ³ /min)	in ³ /min
0.	0	0.	0
0.005	5	0.18	305
0.01	10	0.35	610
0.02	20	0.71	1220
0.05	50	1.77	3051
0.1	100	3.53	6102
0.2	200	7.06	12205
0.5	500	17.65	30512
1.0	1000	35.3	61024
2.0	2000	70.6	122047
5.0	5000	176.5	305119
10.0	1000	353.0	610237

風速 / Air Speed		
m/sec	Km/H	in/sec
0	0.	0.
1	3.6	39.4
2	7.2	78.7
5	18.0	196.9
10	36.0	393.7
20	72.0	787.4
50	180.0	1968.5
100	360.0	3937.0
200	720.0	7874.0

馬力 / Electrical Power		
W	kW	hp
1	0.001	0.0013
1000	1	1.341
745.7	0.746	1

Single stage 單段式



HB-100 系列 Series



HB-200 系列 Series



HB-300 系列 Series



HB-400 系列 Series



HB-600 系列 Series



HB-800 系列 Series



HB-900 系列 Series



皮帶式系列 V-Belt series

Double stage 雙段式



HB-230 系列 Series



HB-330 系列 Series



HB-430 系列 Series



HB-630 系列 Series



HB-640 系列 Series



HB-830 系列 Series



HB-840 系列 Series



皮帶式系列 V-Belt series